

PST600E, PSI6000

Технические характеристики

По вопросам продаж и поддержки обращайтесь:

Алматы (7273)495-231	Казань (843)206-01-48	Новокузнецк (3843)20-46-81	Смоленск (4812)29-41-54
Архангельск (8182)63-90-72	Калининград (4012)72-03-81	Новосибирск (383)227-86-73	Сочи (862)225-72-31
Астрахань (8512)99-46-04	Калуга (4842)92-23-67	Омск (3812)21-46-40	Ставрополь (8652)20-65-13
Барнаул (3852)73-04-60	Кемерово (3842)65-04-62	Орел (4862)44-53-42	Сургут (3462)77-98-35
Белгород (4722)40-23-64	Киров (8332)68-02-04	Оренбург (3532)37-68-04	Тверь (4822)63-31-35
Брянск (4832)59-03-52	Краснодар (861)203-40-90	Пенза (8412)22-31-16	Томск (3822)98-41-53
Владивосток (423)249-28-31	Красноярск (391)204-63-61	Пермь (342)205-81-47	Тула (4872)74-02-29
Волгоград (844)278-03-48	Курск (4712)77-13-04	Ростов-на-Дону (863)308-18-15	Тюмень (3452)66-21-18
Вологда (8172)26-41-59	Липецк (4742)52-20-81	Рязань (4912)46-61-64	Ульяновск (8422)24-23-59
Воронеж (473)204-51-73	Магнитогорск (3519)55-03-13	Самара (846)206-03-16	Уфа (347)229-48-12
Екатеринбург (343)384-55-89	Москва (495)268-04-70	Санкт-Петербург (812)309-46-40	Хабаровск (4212)92-98-04
Иваново (4932)77-34-06	Мурманск (8152)59-64-93	Саратов (845)249-38-78	Челябинск (351)202-03-61
Ижевск (3412)26-03-58	Набережные Челны (8552)20-53-41	Севастополь (8692)22-31-93	Череповец (8202)49-02-64
Иркутск (395)279-98-46	Нижний Новгород (831)429-08-12	Симферополь (3652)67-13-56	Ярославль (4852)69-52-93
Россия (495)268-04-70	Киргизия (996)312-96-26-47	Казахстан (7172)727-132	

PS 6000

The integrated system for perfect resistance welding

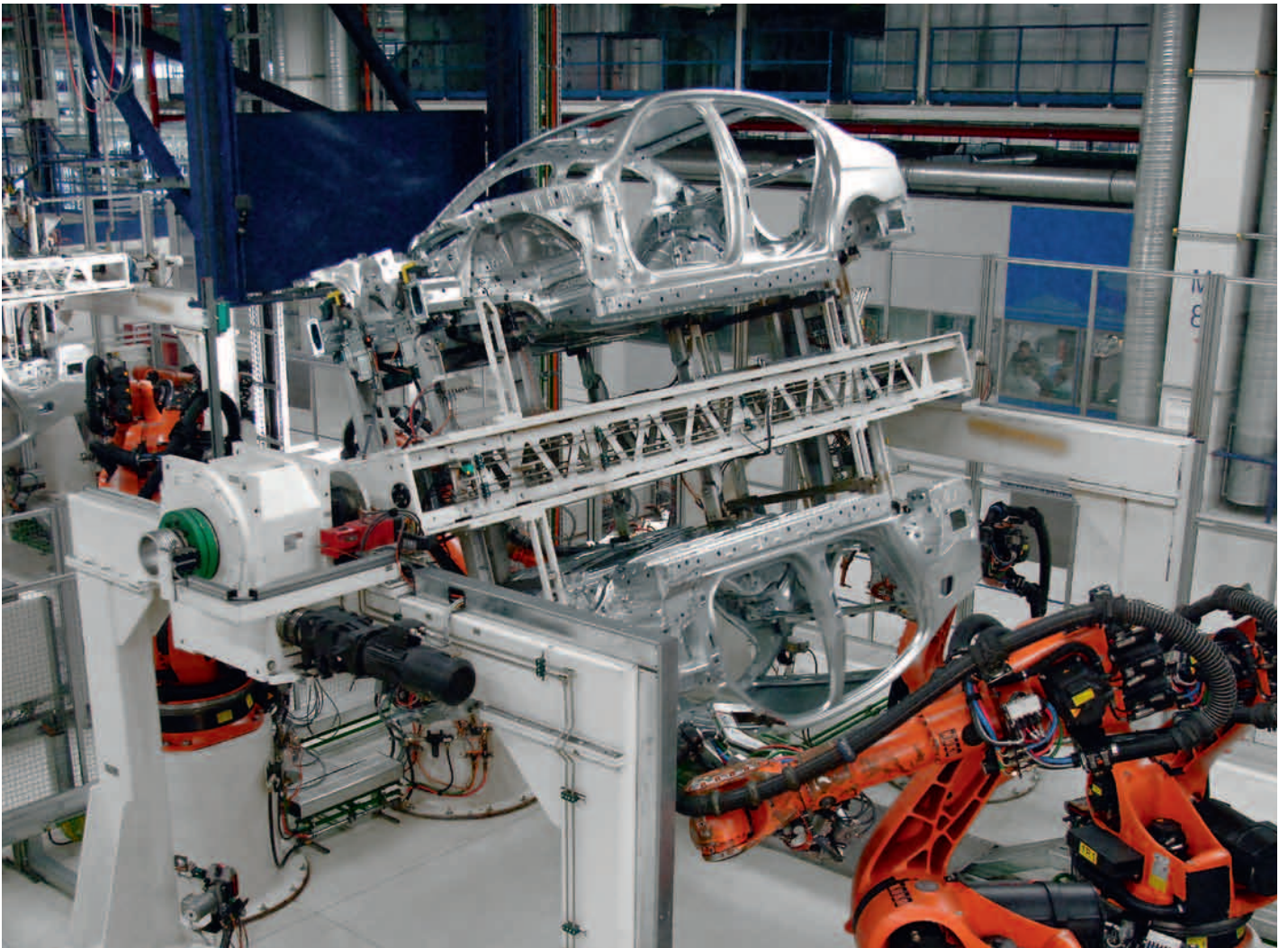

PS 6000 – powerful in medium frequency and AC applications

Used in countless applications, welding systems made by the European market leader Bosch Rexroth are the first choice of satisfied car manufacturers, tier one suppliers and welding equipment manufacturers worldwide.

PS 6000 for applications up to 360 kA increases process reliability, reduces rework costs and provides consistent weld spot quality – even with the most complex material combinations.

The modular concept behind the PS 6000 integrates fully compatible and coordinated components in one particularly cost-effective system:

- ▶ Intelligent inverters
- ▶ Powerful medium frequency transformers

The flexible control system, adaptive control modes and highly-dynamic servo drives allow you to break into new innovative applications. Standard functions such as constant-current regulation, pressure regulation, electrode management concepts and tip dressing, ensure that weld quality lives up to your demands.

Benefits

- ▶ High reliability achieved through the use of well tried and tested technology
- ▶ Maximum flexibility in the I/O and network area thanks to plug-in modules such as PROFIBUS, PROFINET IO, DeviceNet and EtherNet/IP
- ▶ 100 % quality control and documentation of spot welds
- ▶ Innovative functions for process monitoring
- ▶ Expulsion reduction achieved by adaptive control of the welding process
- ▶ Servo gun control system
- ▶ Windows-based user interface for all process functions with SQL database
- ▶ Extensive monitoring functions for maximum system protection
- ▶ Flexibility for retrofitting function and modules



PS 6000 – the powerful system solution for the automotive industry, suppliers and welding equipment manufacturers.

System components

Intelligent inverters

Modular medium frequency resistance welding control system with optional servo gun control and PSQ 6000 process module for adaptive control and quality monitoring. Upgrades are possible with plug-in I/O modules for all commonly used networks.



Powerful medium frequency transformers

Medium frequency transformers combining resistance welding with high power density compact dimensions and low weight. Included features: temperature monitoring, current sensor and safety resistor.



Adaptive current/voltage control

Welding controller for enhanced process stability and assured spot weld quality. Extensive monitoring functions verify welding system functionality. Unique Q-Stop logic optimizes system productivity.

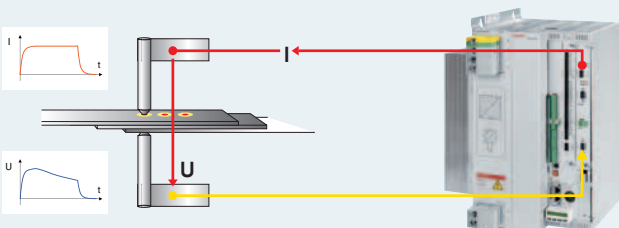

Development/engineering



System solution

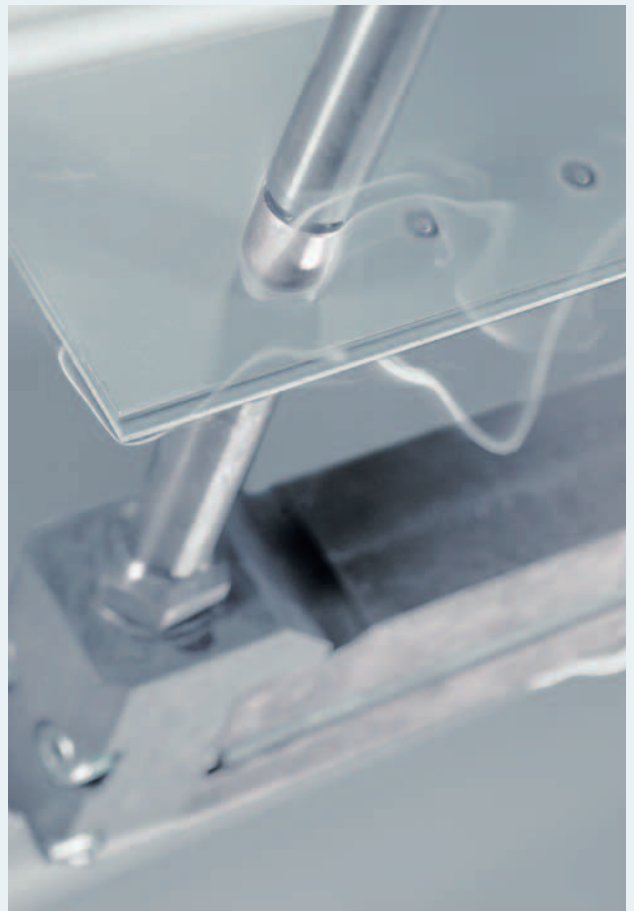

PSI 6000 – the right inverter any time for any application

The intelligent PSI 6000 inverters have been specifically designed for spot, projection and resistance seam welding. The extensive control functions guarantee high process reliability. The PSI 6000 family offers a variety of additional functions for welding high-strength metals, aluminium and three sheet stackups.

The 1,000 Hz medium frequency/DC technology has proven its economic efficiency in many applications compared to other processes:

- ▶ Higher weld quality by more dynamic current control than can be achieved with AC technology
- ▶ Weld-ability of many materials increased by more powerful energy insertion

- ▶ Expulsion reduced by decreased welding current and/or current time
- ▶ Electrode life lengthened thanks to lower thermal and mechanical load on the electrode tips
- ▶ Smaller and lighter transformers for integration into the weld gun

Property	PSI 6200/w1	PSI 6300/a1	PSI 6300/a2	PSI 6300/w1	PSI 6300/w2	PSI 6400/w1	PSI 6500/w1
Weight	approx. 56 kg	approx. 20 kg	approx. 21kg	approx. 25 kg	approx. 25 kg	approx. 56 kg	approx. 70 kg
Supply voltage range	400...480 V	400...480 V	500...690 V	400...480 V	500...690 V	400...480 V	400...480 V
Rated mains current (max. thermal continuous current)	220 A	110 A	110 A	110 A	110 A	220 A	330 A
Max. primary current	1,200 A	800 A	800 A	800 A	800 A	1,600 A	2,400 A
Max. secondary current*	54 kA	36 kA	36 kA	36 kA	36 kA	60 kA	120 kA
Required connection cross-section	95 mm ²	35 mm ²	35 mm ²	35 mm ²	35 mm ²	95 mm ²	2 – 4 cables; per cable 120 mm ²

Mains voltage a1/w1: air-cooled, water-cooled 400 V to 480 V, 50/60 Hz
a2/w2: air-cooled, water-cooled 500 V to 690 V, 50/60 Hz

* Specific to the welding transformer used.

PSI 62C0 inverter

Inverter for steel, aluminum and seam welding applications up to 54 kA

- ▶ Water-cooled
- ▶ PSQ 6000 quality system (optional)
- ▶ Connection to MF transformer of the PSG 6000 series

**PSI 63C0 inverter**

Inverter up to 36 kA for steel applications

- ▶ Air-cooled/water-cooled
- ▶ PSQ 6000 quality system (optional)
- ▶ Connection to MF transformer of the PSG 6000 series

**PSI 64C0 inverter**

Inverter for aluminum applications up to 60 kA

- ▶ Water-cooled
- ▶ PSQ 6000 quality control system (optional)
- ▶ Connection to MF transformer of PSG 6000 series

**PSI 65C0 inverter**

Inverter for resistance seam and projection welding applications up to 120 kA

- ▶ Water-cooled
- ▶ Parallel connection of max. 3 inverters for currents up to 360 kA
- ▶ PSQ 6000 quality system (optional)

**Interfaces for the PSI 6000 series**

Flexible due to pluggable I/O cards and field bus connections.



PST 6000 – cost-effective AC series for standard application

The PST 6000 AC controllers are mechanically identical to the PSI 6300 inverter series. This provides a low-cost migration path to middle-frequency AC at a later time. Naturally these control systems offer you the same flexibility in the I/O area and all the control functions of the entire PS 6000 system.



The AC controllers PST 6000 are designed for applications up to 250 kVA

- ▶ Air-cooled/water-cooled
- ▶ Optimum weld result by means of primary or secondary current control
- ▶ Competitive solution for standard applications

◀ **Left: Air-cooled version for spot-welding applications**

Right: Water-cooled version for projection welding and seam welding applications with increased duty cycle

Characteristic		PST 6100L	PST 6100W	PST 6250L	PST 6250W
Power supply connection grounded TN or TT system		400 V (-20 %) to 600 V (+10 %), 50/60 Hz			
Rated transformer output 20 % duty cycle, at 400 V~ and 80 % transformer load up to 20 % system utilization	kVA	77/145*	167	224	257
Rated transformer output 50 % duty cycle, at 400 V~ and 80 % transformer load up to 50 % system utilization	kVA	16/62.5*	106	65/141*	162
Rated line current; max. continuous thermal current	A	69/130*	150	200	230
Connection cross-section	mm ²	50	50	95	95
Weight	kg	12.5	21	13	21.5

* without/with fan hood

PST 600E – compact power packs for stationary machines and manual welding units

For stationary welding machines and manual welding workstations – the PST 600E AC controllers from Rexroth have a compact, slim design which makes them up to 60 % smaller and lighter.



The AC controllers PST 600E are designed for applications up to 500 kVA

- ▶ Air cooling/water cooling
- ▶ Parallel input/output box with coordinated scope of functions
- ▶ High-precision primary current control without external current sensor – no more cables and connectors
- ▶ Optional slot for fieldbus module (Ethernet)
- ▶ Attractively priced alternative for use on older welding systems

◀ **Left: Air-cooled version for manual welding gun applications and simple projection welding tasks**

Middle: Water-cooled version for manual welding gun and projection welding applications requiring more power

Right: Water-cooled version for welding systems with high performance requirements up to 500 kVA

Characteristic		PST 610EL	PST 610EW	PST 625EL	PST 625EW	PST 650EW
Cooling		Air	Water	Air	Water	Water
Power supply connection grounded TN or TT system		400 V (-20 %) to 600 V (+10 %), 50/60 Hz				
Maximum output current for duty cycle	A %	300/300*, 10/20*	300, 20	389/365*, 15/30*	400, 30	2,400, 10
Rated transformer output 50 % duty cycle, at 400 V- and 80 % transformer load up to 50 % system utilization	kVA	68/95*	95	106/141*	155	500
Rated line current; max. continuous thermal current	A	95/130*	130	200	230	800
Connection cross-section	mm ²	50	50	95	95	240
Weight	kg	8.6	7.9	13	9.1	11.2

* without/with fan hood

PSQ 6000 – for supreme quality in spot welding

The PSQ 6000 control system is designed to monitor quality performance in high-volume production operations. Intelligent current/voltage control maximizes process reliability and provides online verification of spot weld quality. The BOS 6000 operating interface includes logging and documentation features.

The PSQ 6000 has built-in control and monitoring functionality. The XQR control card is available as an upgrade for PSI 6000 series systems.

Adaptive current/voltage control for the highest spot weld quality

The adaptive process control mode gives you added flexibility for future requirements in the welding process. By measuring current and voltage, the resistance and energy can also be recorded, controlled and accurately evaluated during welding. The adaptive control algorithm ensures consistent quality and reduces spatter in demanding welding applications. Expensive rework can be reduced.

Process monitoring

Tolerance limits can be set and monitored for a number of basic process parameters: current, phase angle, electrode voltage, resistance, current time, power and energy. Two consolidated variables, which summarize the basic variables, are provided to simplify system handling:

- ▶ PSF – the process stability factor indicates the stability of the welding process
- ▶ UIP – the quality factor provides an indication of actual spot quality

Q-Stop logic

Patented Q-Stop logic is a very useful extension of monitoring functionality. It enables users to analyze and optimize system productivity by defining how the system reacts to repetitive faults in a program or on a particular part.

Process overview

To provide the big picture, the status of all attached welding controllers is displayed on a bar graph.

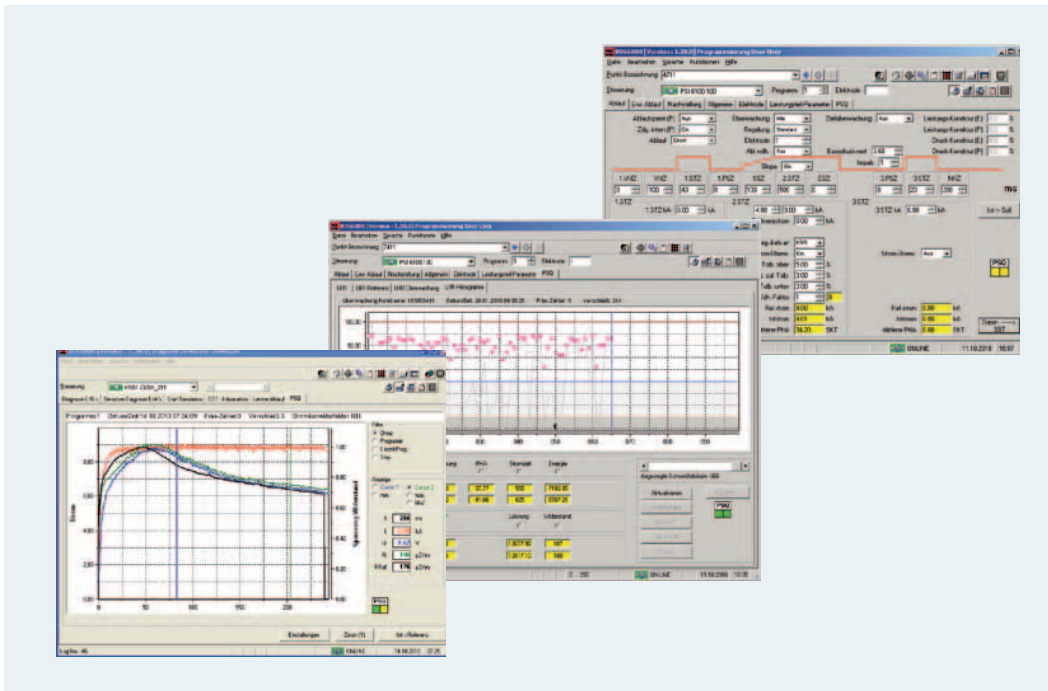
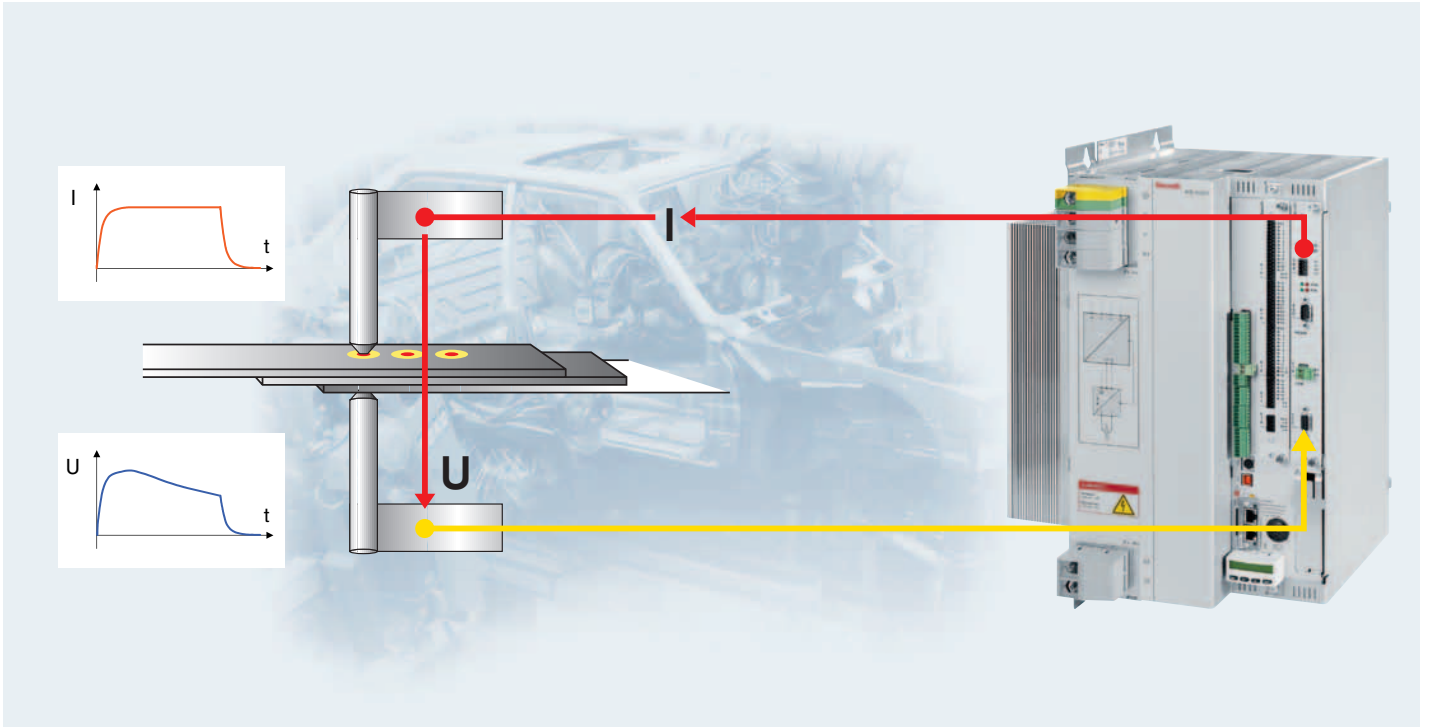

▲ Adaptive current/voltage control – consistent weld quality and reduced expulsion

◀ BOS 6000 – the combined user interface for weld control and quality monitoring

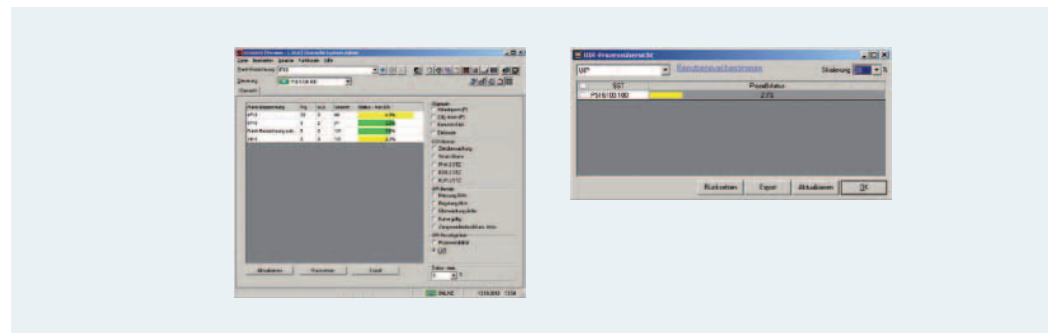

◀ Q-Stop logic and the process overview give you the tools you need to analyze and optimize system productivity

PSQ 6000 – for supreme quality in spot welding

Commissioning strategy

When you are working in the main operating modes (robotic spot welding and manual spot welding), we provide you with highly efficient tools and strategies to speed up and simplify the welding system commissioning process. This approach has a proven track record in many automotive projects.

Process analysis

Process analysis/PSQ Analysis provides vital information during commissioning and ongoing production. You use it during the commissioning phase to determine the monitoring limits which you then load into the controller. You can easily determine which systems have reached an acceptable spatter level. During ongoing production, you can reliably assess the stability of each system right down to the individual spot weld.

Services

On request, we will be right at your side to help you install and set up your welding systems. We can provide assistance in every phase of your project from parameterization right through to final optimization. Rexroth has experience in working with production line builders and end users.

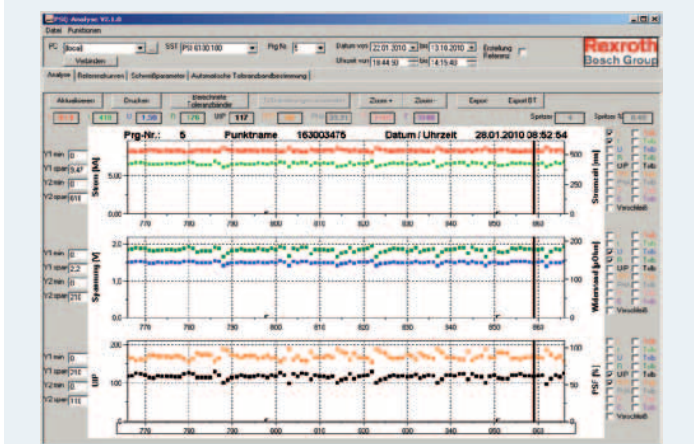
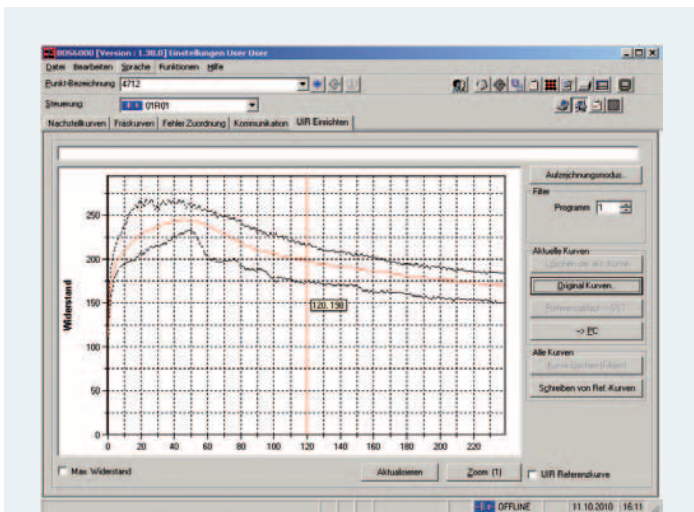

▲ Our user interfaces and tools provide the support you need during commissioning and ongoing production

Integrated servo gun controller for maximum flexibility

The new welding control cabinet from Bosch Rexroth combines a welding and servo gun controller in a compact cabinet concept. This series, which features an integrated gun controller and the compact GDM (gun data module) for saving welding gun data, enables maximum integration and flexibility.

Compact welding case series with integrated servo gun controller

The high-performance PSI 63C0 welding controller for steel applications and the integrated servo gun controller with the compact IndraDrive Cs drive system are combined into a compact control cabinet concept.

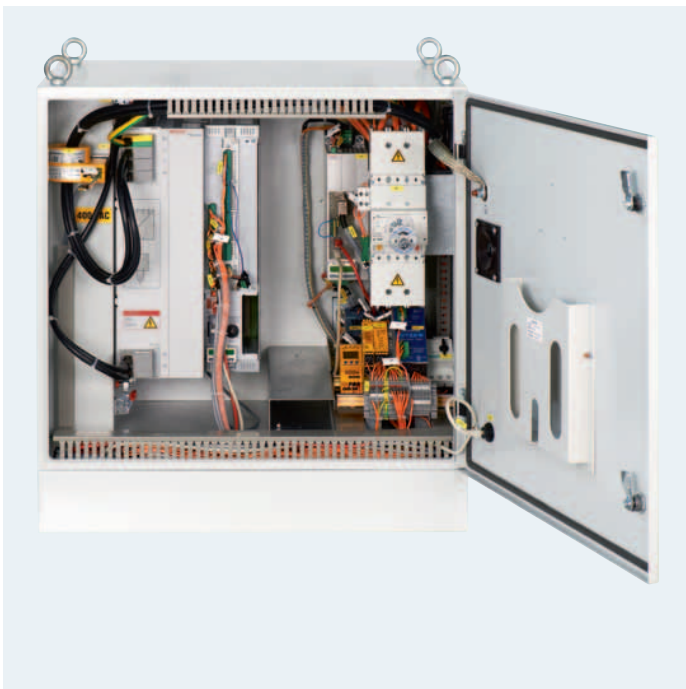

Features

- ▶ Control cabinet variants for application as a suspended system, floor standing cabinet, or robot cabinet
- ▶ Comprehensive programming via BOS 6000

Benefits

- ▶ Installation surface maximized as a result of small footprint
- ▶ Greater flexibility via standardized interfaces
- ▶ Reduced training outlay thanks to proven programming environment

Gun data module GDM

The compact GDM records and saves welding gun data and can make it available via the Ethernet-based interface for production and maintenance purposes.

Benefits

- ▶ Compact construction that requires minimal installation space
- ▶ Improved quality due to the production and maintenance data saved. This facilitates preventive maintenance of the welding gun for optimal, cost-efficient production.
- ▶ Quick, reliable transfer of data to the welding controller via the Ethernet-based interface

Welding aluminum in a cost-effective, reliable manner

The automotive industry is increasingly concentrating on the potential of lightweight, to reduce weight and thus consumption. The usage of aluminum required high process knowledge – therefore all this knowledge must be coordinated and built up. Rexroth offers a full range of cost-efficient and reliable welding solutions – including for aluminum.

Bosch Rexroth is the only market provider worldwide which defines the requirements for efficiency and reliability requirements for welding aluminum. The welding process is backed up by new control and monitoring algorithm.

For the first time, automotive manufactures has the possibility to work with a system solution by Bosch Rexroth which can reliably weld aluminum for automotive bodywork, for the same costs like steel welding.

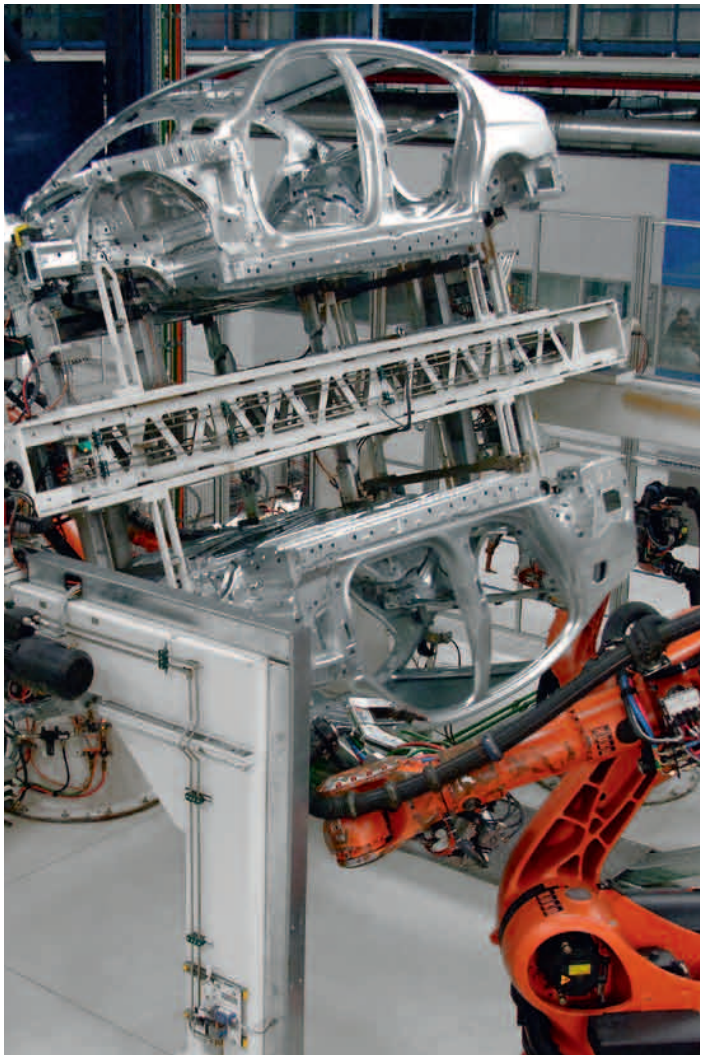

Inverter and transformers for aluminum welding

The PSI64CO adaptive welding inverter for aluminum is developed to identify the physical characteristics of the material. The comprehensive monitoring and the active regulation of the welding procedure during the operational process is now practicable for the first time. Therefore we use the proven mid-frequency/direct current technology.

The material-specific properties of aluminum require higher welding currents among shorter welding times. The PSG 6180 RSTK provided ideal prerequisites for aluminum welding and is thus one unit of many in Bosch Rexroth's comprehensive line of transformers.

- ▶ The Bosch Rexroth solution for aluminum welding: The PSI 64CO inverter and PSG 6180 RSTK transformer (MF 180)



Transformers programm – for maximum efficiency and accuracy

The medium-frequency transformer series are an additional asset to our successful PSI 6000 inverter system. Precisely coordinated and perfectly compatible, these components facilitate optimum power transfer and additional monitoring functions between the inverter and transformer, resulting in greater profitability and enhanced precision in welding.

PSG 6000 – compact medium-frequency transformers

The medium-frequency transformers in the PSG 6000 series are optimized for greater power and operating efficiency in resistance welding. They are characterized by a particularly compact design and low weight.

Features

- ▶ Process monitoring by
 - Integrated current measuring coil
 - Adaptive control of the welding control

- ▶ Component protection by
 - Integrated temperature monitoring of the winding package and the rectifier unit
 - Programmable monitoring limit values in the welding control

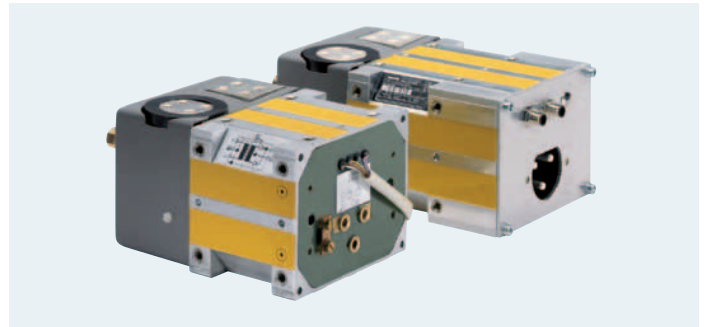

PSG 6000 transformer series		PSG 6130	PSG 6170	PSG 6250
Output up to 20 % ED	kVA	130	170	250
Nominal DC voltage	V	9.5	9.5	14
Continuous on-state current	kA	6.5	8	8
Cooling water flow	l/min	6	8	8
Dimensions W x H x D	mm	160 x 127 x 262	160 x 127 x 297	160 x 127 x 300
Weight	kg	16	19	23

Benefits of middle frequency transformers from Rexroth

- ▶ Standardized platform transformer for the automotive industry
- ▶ Optimal power transfer
- ▶ Monitoring function that oversees interaction between the inverter and transformer
- ▶ Optimal application possibilities thanks to a compact construction and low weight

PSG 6130.xx.RSTK (MF 100) – the new platform transformer

The compact, lightweight middle frequency transformers from the PSG 6130.xxRSTK series are optimized for all global robot applications up to 130 kVA.

Features

- ▶ For all robot applications
- ▶ Compliant with DIN EN ISO 22829 requirements and welding gun specifications for the automotive sector
- ▶ Primary connection via single-conductor plug connector
- ▶ Common AIDA push-pull sensor connector for temperature, force, voltage, and current signals
- ▶ Suitable for primary, secondary, and adaptive welding current controls



Platform transformer PSG 6130.xx.RSTK (MF 100)

Output	kVA	130
Nominal DC voltage	V	9
Continuous on-state current	kA	6.5
Cooling water flow	l/min	6
Dimensions W x H x D	mm	106 x 150 x 332
Weight	kg	16.8

An overview of the medium-frequency transformers

PSG 6130	Primary connection	Internal current measuring coil and temperature monitoring	Nominal DC voltage	Nominal primary voltage
6130.00AS	via interface box	●	9.5 V	530 V
6130.00PS	via MC 150	●	9.5 V	530 V
6130.00PTK	via MC 150		9.5 V	530 V
6130.00PSTK	via MC 150	●	9.5 V	530 V
6130.xxRSTK	via single wire	●	9 V	530 V/645 V/926 V

PSG 6170 and PSG 6180	Primary connection	Internal current measuring coil and temperature monitoring	Nominal DC voltage	Nominal primary voltage
6170.00PTK	via MC 150		9.5 V	530 V
6170.00PSD	via MC 150	●	9.5 V	530 V
6170.68AT	via interface box		9.5 V	530 V
6180.xxRSTK	via single wire	●	14 V	530 V/645 V

PSG 6170 and PSG 6250	Primary connection	Internal current measuring coil and temperature monitoring	Nominal DC voltage	Nominal primary voltage
6170.00ASTK	via interface box*	●	9.5 V	530 V
6250.00ASTK	via interface box	●	14 V	530 V

* Both interface boxes as transformer accessory (TH 6000 MC and TH 6000 PG).

PSG 6160 and PSG 6230	Primary connection	Internal current measuring coil and temperature monitoring	Nominal DC voltage	Nominal primary voltage
6160.00TS231	via PG	●	9 V	500 V
6160.00TS232	via PG	●	9 V	650 V
6160.00TS233	via PG	●	9 V	800 V
6230.00GM234	via PG		13 V	500 V
6230.00GM235	via PG		13 V	650 V
6230.00GM236	via PG		13 V	800 V

Transformers

Variants of primary connection

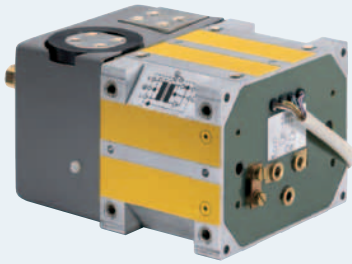

◀ Example:
PSG 6130.00 AS

Connection with
additional, individual
terminal box



◀ Example:
PSG 3075.10 PZ

Connection via
round plug connector



◀ Example:
PSG 6130.00 RSTK

Connection via
single-conductor
plug connector



◀ Example:
PSG 6160.00GM234

Connection via
PG fitting

STC Teach software function (Sheet Thickness Combination) – for expedited initial start-up

The new STC Teach software function makes it possible to optimize welding procedures for different panel thickness combinations and materials in advance by running tests in a laboratory. These parameters and the set-in welding combinations used by the manufacturer were entered in a central database to minimize the commissioning time for spot welds up to 90 %.

Features

- ▶ Welding parameters are determined in advance by carrying out test welds in a laboratory
- ▶ The predetermined parameters allow production operation to take place immediately while actively monitoring and regulating all spot welds
- ▶ Product derivatives can be quickly and easily communicated (taught)
- ▶ Central data storage for welding parameters, reference curves, and quality thresholds
- ▶ Parameter sets can be alternatively selected for every panel thickness combination
- ▶ Easy assignment of the spot weld tables determined via the BOS 6000 user interface

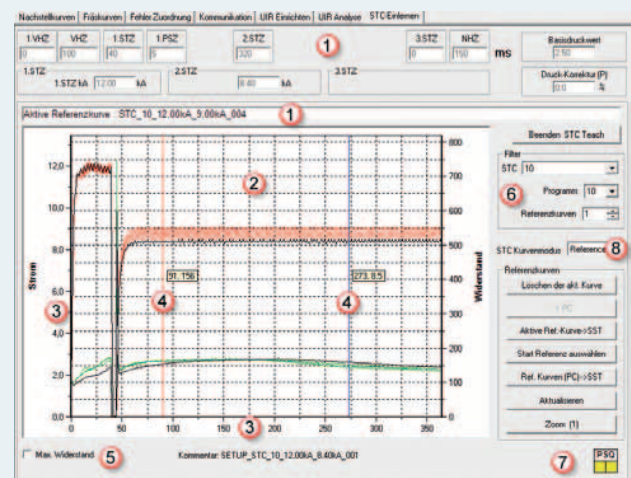

- ① Information about display diagram
- ② Display diagram
- ③ Drag-and-drop functionality for moving axes
- ④ Drag-and-drop functionality for moving cursor markers
- ⑤ Checkbox for maximum resistance and maximum force
- ⑥ Parameter group filter
- ⑦ Area for displaying welding sparks
- ⑧ STC curve mode

BOS 6000 – operation and observation to perfection

The windows-based BOS 6000 user interface with built-in SQL database function makes it very easy to operate the system and monitor performance. You can operate both the welding controller and the process module on a standardized BOS 6000 user interface. The BOS 6000 also provides connectivity to higher-level data processing systems.

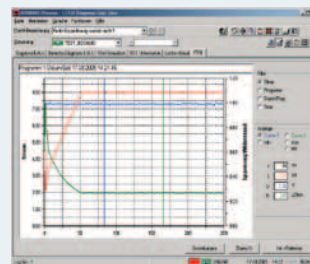
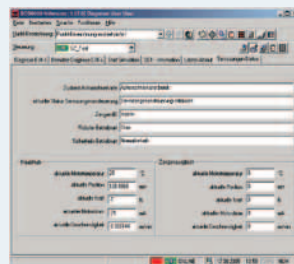
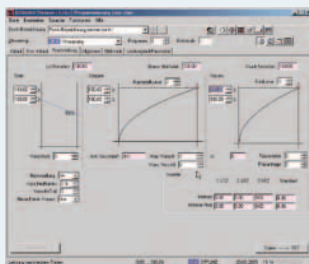

BOS 6000 – the integrated user interface for weld control and process module



IndraControl VCH 05 – versatile handheld console for mobile applications

The web-based IndraControl VCH 05 handheld console allows you to operate any number of controllers on the go. No specialized knowledge is required as handling and use are straightforward. State-of-the-art processor and communication interfaces enable quick access to welding parameters and diagnostic utilities.

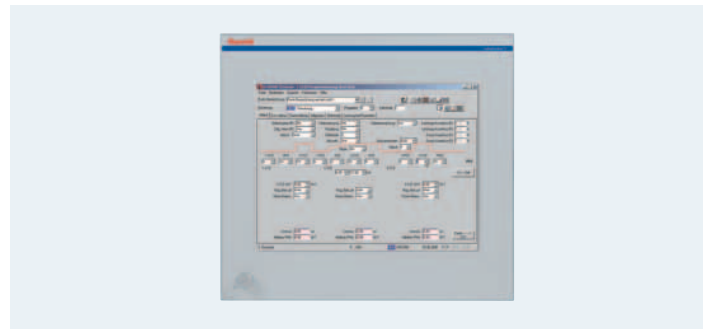

IndraControl VPP 40 – compact PC system for industrial applications

The robust VPP 40 industrial PC is the complete solution for control, operation and visualization. It is specifically designed for use as a stand-alone or networked PC and can be integrated inexpensively in control cabinets. Depending on the operating requirements this PC can be supplied with a touch screen or keyboard.

По вопросам продаж и поддержки обращайтесь:

Алматы (7273)495-231	Казань (843)206-01-48	Новокузнецк (3843)20-46-81	Смоленск (4812)29-41-54
Архангельск (8182)63-90-72	Калининград (4012)72-03-81	Новосибирск (383)227-86-73	Сочи (862)225-72-31
Астрахань (8512)99-46-04	Калуга (4842)92-23-67	Омск (3812)21-46-40	Ставрополь (8652)20-65-13
Барнаул (3852)73-04-60	Кемерово (3842)65-04-62	Орел (4862)44-53-42	Сургут (3462)77-98-35
Белгород (4722)40-23-64	Киров (8332)68-02-04	Оренбург (3532)37-68-04	Тверь (4822)63-31-35
Брянск (4832)59-03-52	Краснодар (861)203-40-90	Пенза (8412)22-31-16	Томск (3822)98-41-53
Владивосток (423)249-28-31	Красноярск (391)204-63-61	Пермь (342)205-81-47	Тула (4872)74-02-29
Волгоград (844)278-03-48	Курск (4712)77-13-04	Ростов-на-Дону (863)308-18-15	Тюмень (3452)66-21-18
Вологда (8172)26-41-59	Липецк (4742)52-20-81	Рязань (4912)46-61-64	Ульяновск (8422)24-23-59
Воронеж (473)204-51-73	Магнитогорск (3519)55-03-13	Самара (846)206-03-16	Уфа (347)229-48-12
Екатеринбург (343)384-55-89	Москва (495)268-04-70	Санкт-Петербург (812)309-46-40	Хабаровск (4212)92-98-04
Иваново (4932)77-34-06	Мурманск (8152)59-64-93	Саратов (845)249-38-78	Челябинск (351)202-03-61
Ижевск (3412)26-03-58	Набережные Челны (8552)20-53-41	Севастополь (8692)22-31-93	Череповец (8202)49-02-64
Иркутск (395)279-98-46	Нижний Новгород (831)429-08-12	Симферополь (3652)67-13-56	Ярославль (4852)69-52-93
Россия (495)268-04-70	Киргизия (996)312-96-26-47	Казахстан (7172)727-132	