

# VarioFlow

## Технические характеристики

### По вопросам продаж и поддержки обращайтесь:

Алматы (7273)495-231	Казань (843)206-01-48	Новокузнецк (3843)20-46-81	Смоленск (4812)29-41-54
Архангельск (8182)63-90-72	Калининград (4012)72-03-81	Новосибирск (383)227-86-73	Сочи (862)225-72-31
Астрахань (8512)99-46-04	Калуга (4842)92-23-67	Омск (3812)21-46-40	Ставрополь (8652)20-65-13
Барнаул (3852)73-04-60	Кемерово (3842)65-04-62	Орел (4862)44-53-42	Сургут (3462)77-98-35
Белгород (4722)40-23-64	Киров (8332)68-02-04	Оренбург (3532)37-68-04	Тверь (4822)63-31-35
Брянск (4832)59-03-52	Краснодар (861)203-40-90	Пенза (8412)22-31-16	Томск (3822)98-41-53
Владивосток (423)249-28-31	Красноярск (391)204-63-61	Пермь (342)205-81-47	Тула (4872)74-02-29
Волгоград (844)278-03-48	Курск (4712)77-13-04	Ростов-на-Дону (863)308-18-15	Тюмень (3452)66-21-18
Вологда (8172)26-41-59	Липецк (4742)52-20-81	Рязань (4912)46-61-64	Ульяновск (8422)24-23-59
Воронеж (473)204-51-73	Магнитогорск (3519)55-03-13	Самара (846)206-03-16	Уфа (347)229-48-12
Екатеринбург (343)384-55-89	Москва (495)268-04-70	Санкт-Петербург (812)309-46-40	Хабаровск (4212)92-98-04
Иваново (4932)77-34-06	Мурманск (8152)59-64-93	Саратов (845)249-38-78	Челябинск (351)202-03-61
Ижевск (3412)26-03-58	Набережные Челны (8552)20-53-41	Севастополь (8692)22-31-93	Череповец (8202)49-02-64
Иркутск (395)279-98-46	Нижний Новгород (831)429-08-12	Симферополь (3652)67-13-56	Ярославль (4852)69-52-93
Россия (495)268-04-70	Киргизия (996)312-96-26-47	Казахстан (7172)727-132	

# VarioFlow plus – эффективная транспортировка штучных продуктов

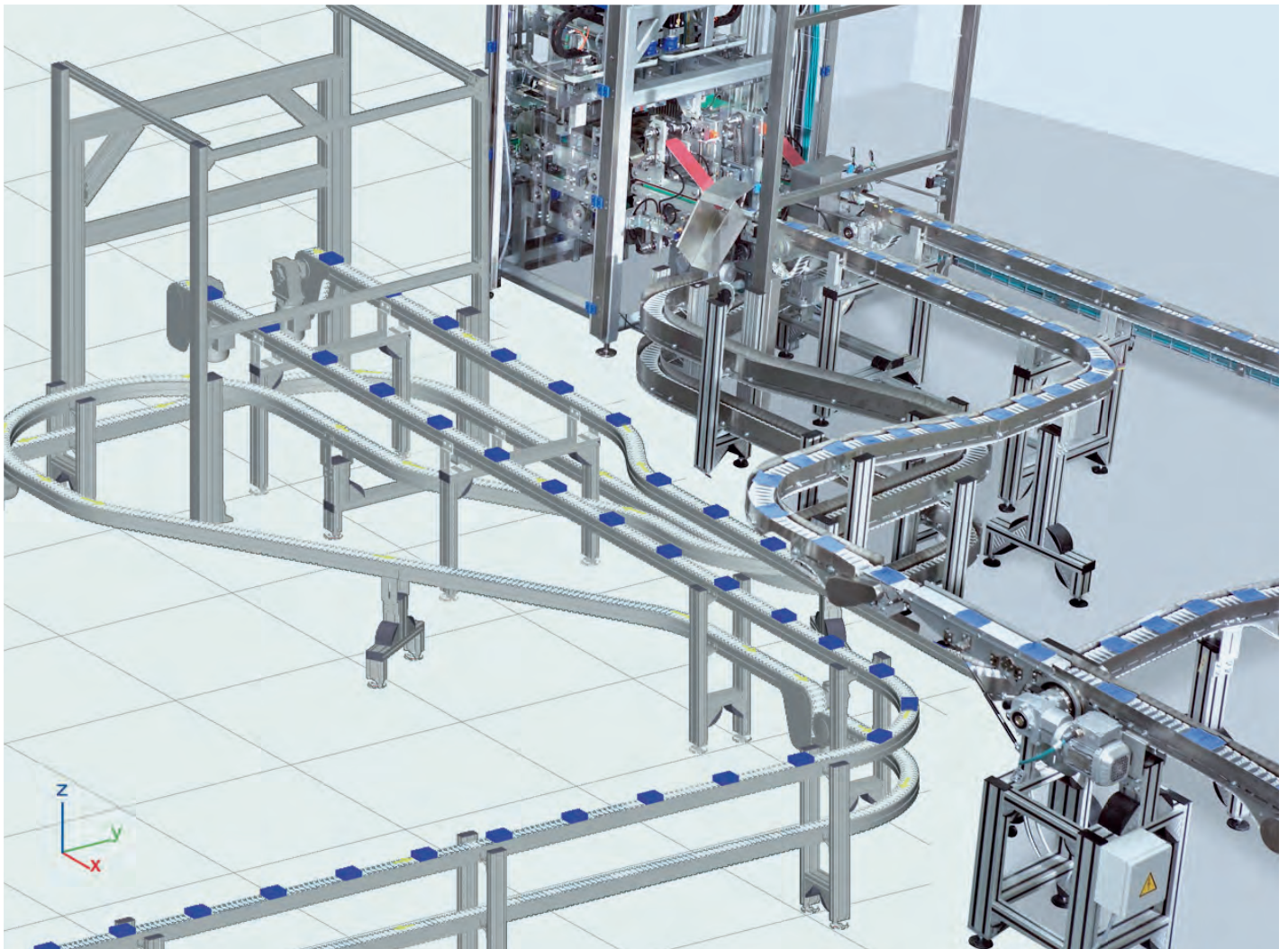





---

### Преимущества для заказчика

- 04 Ваш «плюс»: свобода планирования
- 06 Ваш «плюс»: надежность и простота обслуживания
- 08 Ваш «плюс»: инновационное решение
- 10 Ваш «плюс»: конфигурация



---

### Решения Рекрот

- 12 Конвейерная технология для производственных линий
- 14 Первичная упаковка
- 16 Вторичная упаковка
- 18 Окончательная упаковка
- 20 Решение для сборочных линий
- 22 Связующее звено для машин одной линии
- 24 Все о системе цепных конвейеров



- 
- 26 Сервис, глобальное партнерство

## Гибкость планирования и высокая скорость пуска в эксплуатацию благодаря интеллектуальным решениям

Продуманное исполнение приводов позволяет обеспечить свободу планирования: место установки двигателей может быть выбрано непосредственно на рабочей площадке. Уникальная технология соединения экономит время на этапе монтажа и позволяет очень легко выполнять модификацию и наращивание системы.

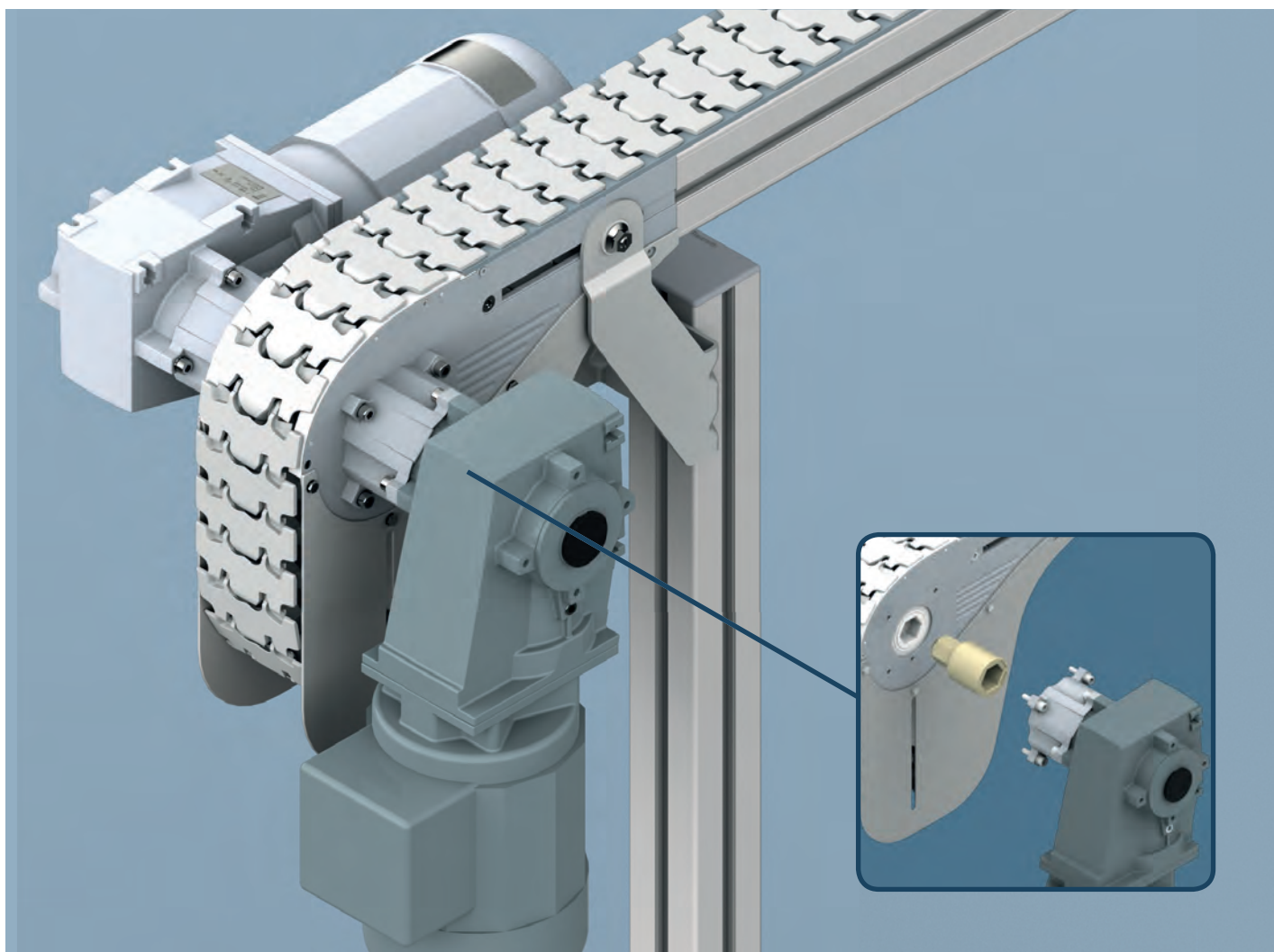

**Требование рынка**

- ▶ Высокая гибкость и свобода планирования на этапе проектирования
- ▶ Простота монтажа и пуска в эксплуатацию

**Наше решение**

- ▶ Универсальные базовые модули с комплектами приводов
- ▶ Полые валы с обеих сторон приводного и натяжного модулей
- ▶ Боковой монтаж рельсовых направляющих
- ▶ Оптимизированная технология соединения

**Ваша выгода**

- ▶ Различные варианты комбинирования благодаря модульному дизайну
- ▶ Свободный выбор места размещения двигателя на площадке
- ▶ Дополнительные связующие компоненты для перемещения (приводной мостик)
- ▶ Возможность установки привода на поворотные станции с колесом
- ▶ Поверхности скольжения не требуют длительной механической обработки
- ▶ Минимизация шума и износа
- ▶ Экономия времени из-за малого количества элементов крепежа

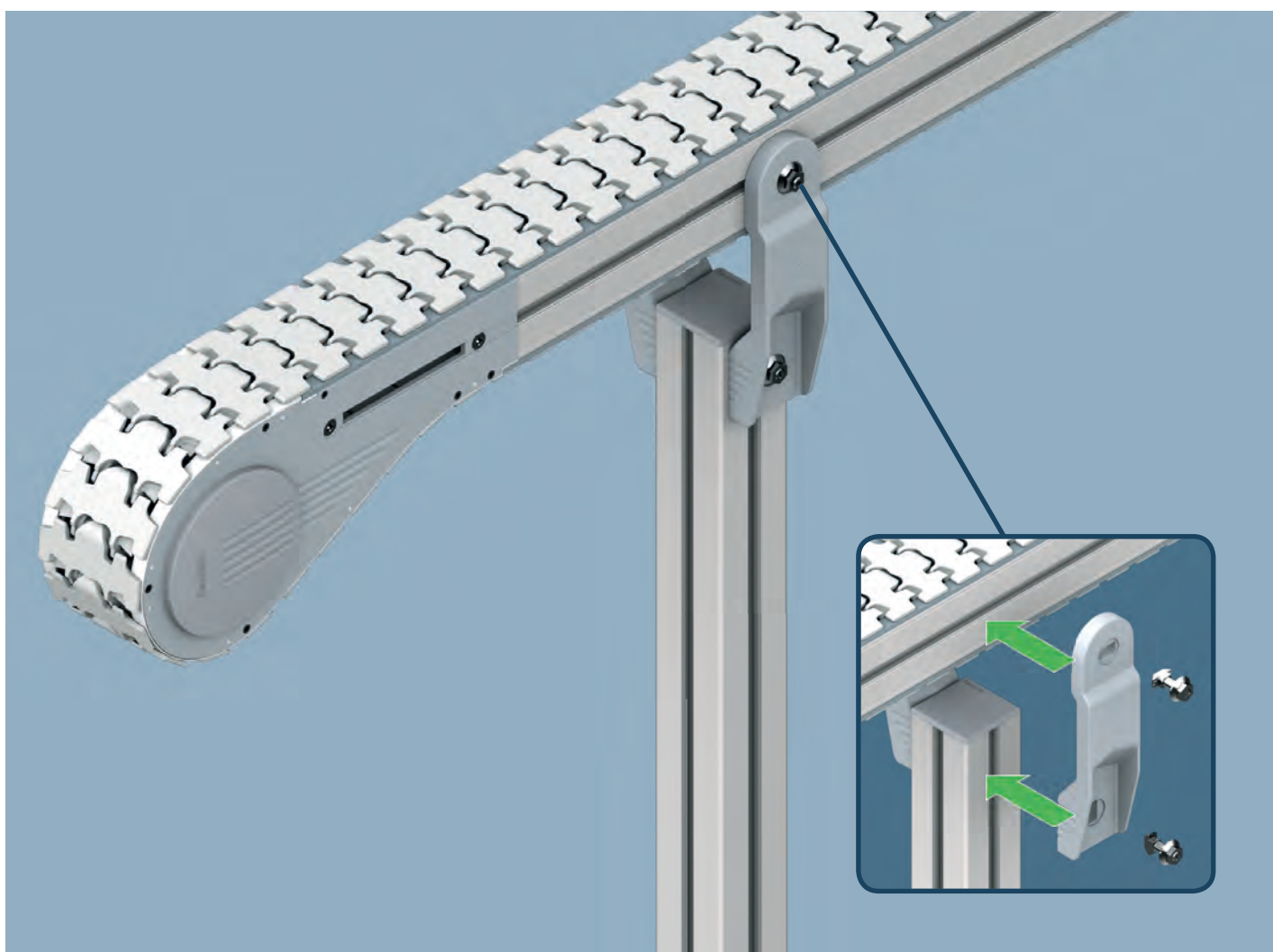



## Оптимальные рабочие условия благодаря тихой работе и простоте обслуживания

Удобная для обслуживания конвейерная система *VarioFlow plus* создает оптимальные рабочие условия. Улучшенные характеристики скольжения и материалы с низким коэффициентом трения обеспечивают тихую рабочую атмосферу. Меньшее количество стыков и низкое трение качения на горизонтальных поворотных участках способствуют снижению износа и сокращению простоев.

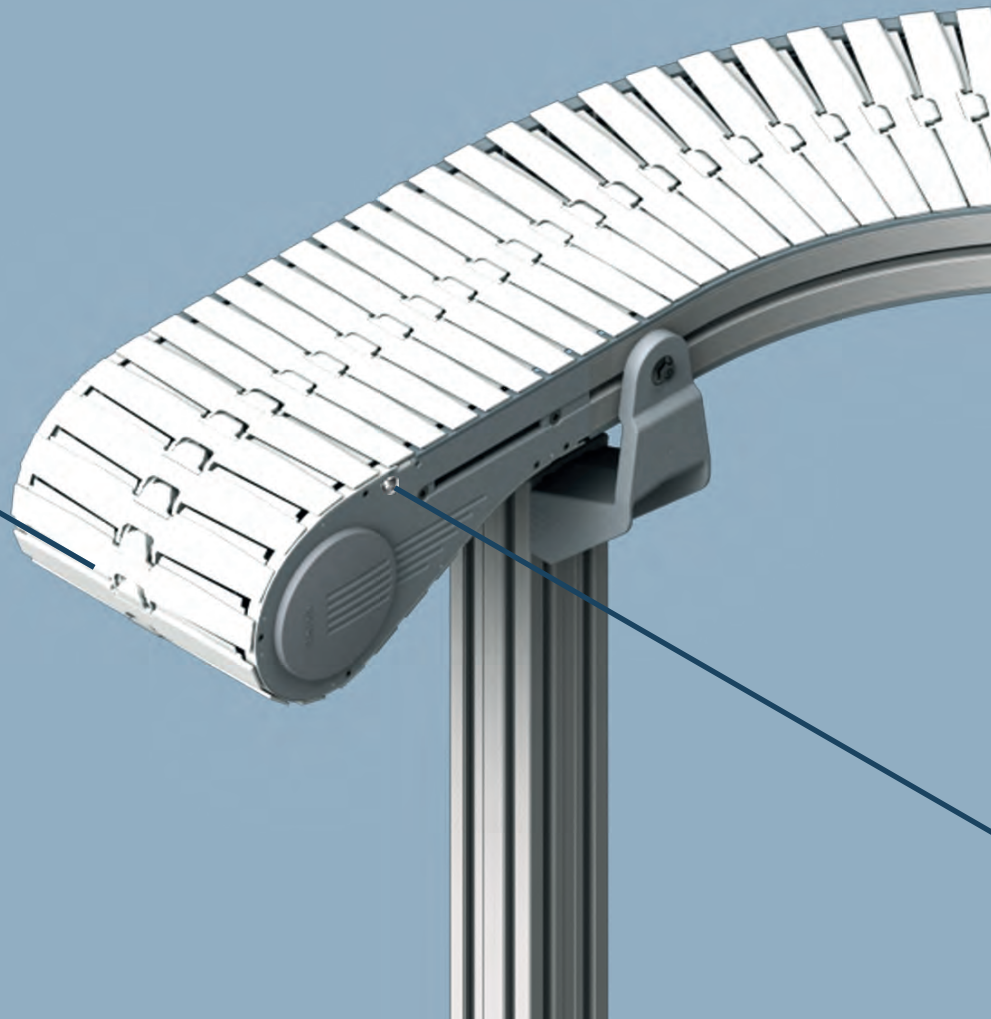
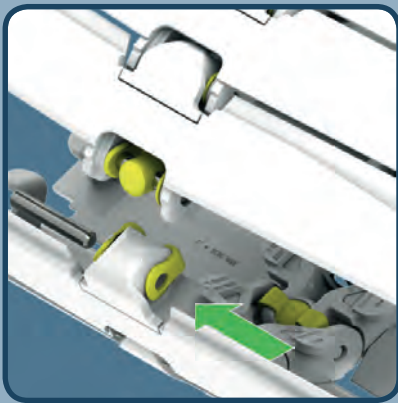

## Требование рынка

- ▶ Низкий уровень шума
- ▶ Простая в обслуживании конвейерная система

## Наше решение

- ▶ Оптимизированные характеристики скольжения для цепей и направляющих
- ▶ Поверхность скольжения не требует никакой механической обработки
- ▶ Меньше стыков и материалы с низким коэффициентом трения
- ▶ Разъемные звенья цепи из разных материалов
- ▶ Трение качения для всех типоразмеров горизонтальных поворотных секций

## Ваша выгода

- ▶ Наилучшие рабочие условия благодаря минимальному уровню шума во время работы
- ▶ Увеличенный срок службы
- ▶ Снижение времени простоев

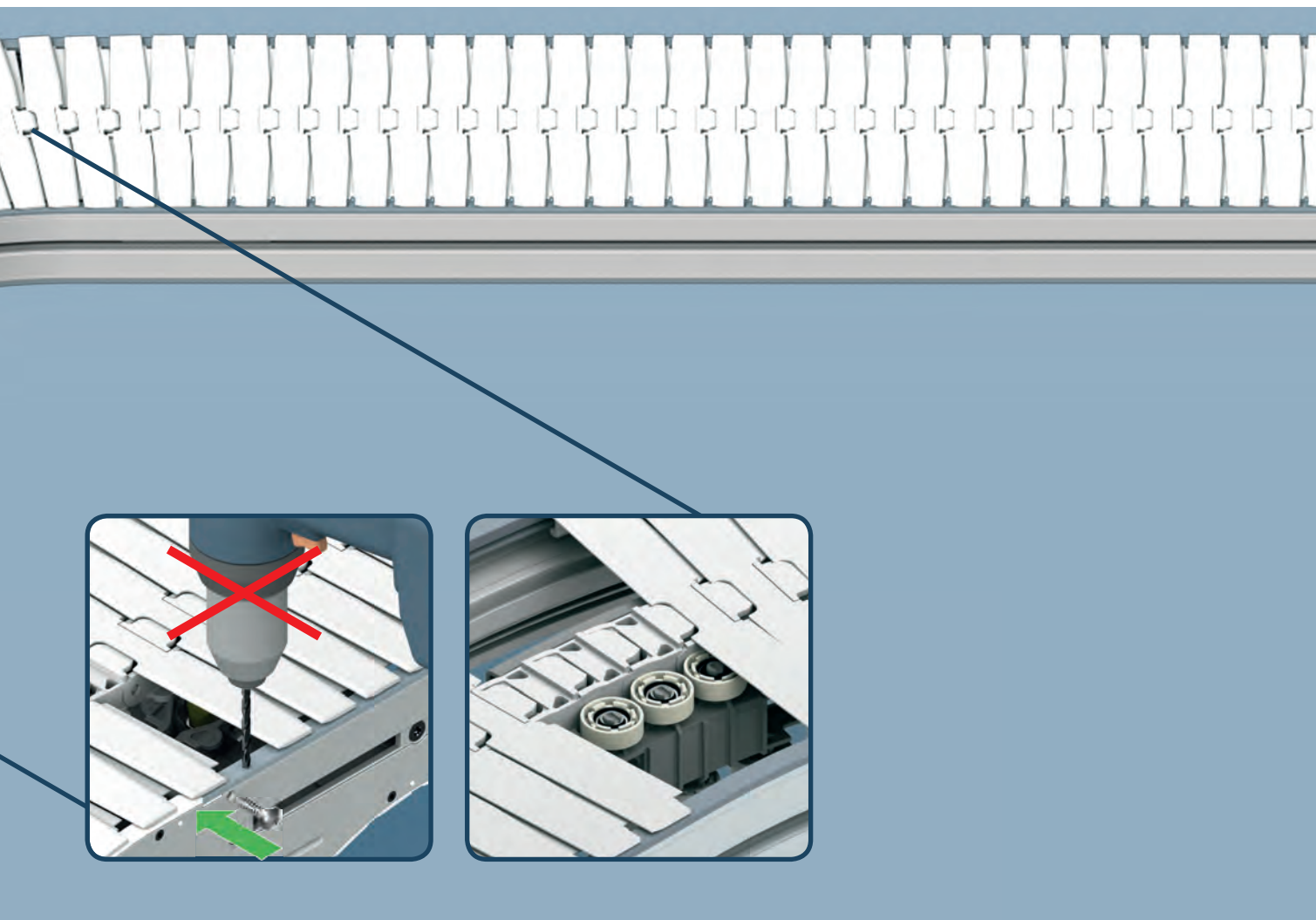

# Ваш «плюс»: инновационное решение



- ▶ Простота очистки благодаря наличию дренажных поверхностей

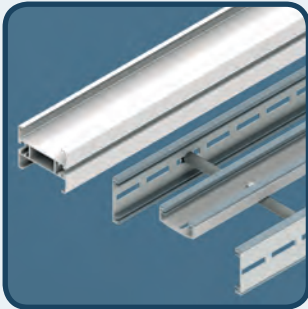

- ▶ Полноценная линейка продукции из алюминия и нержавеющей стали размером 65, 90, 120, 160, 240, 320 мм
- ▶ Стандартизированные, универсально используемые компоненты



- ▶ Компоненты, подверженные постоянному трению, выполняются из материалов, соответствующих требованиям FDA (Управление по санитарному надзору за качеством пищевых продуктов и медикаментов)
- ▶ Шариковые подшипники из нержавеющей стали, герметизированные с обеих сторон



- ▶ Широкий выбор типов цепей для разных применений
- ▶ Транспортировка небольших деталей с низким уровнем вибрации и возможность накопления благодаря закрытым сочленениям цепи
- ▶ Легкосъемная накладка цепи для типоразмеров от 160 мм

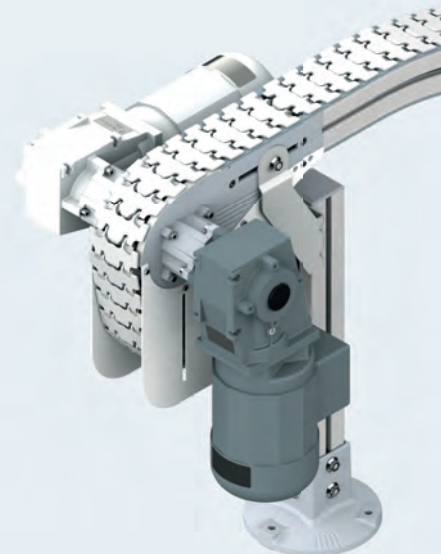



Многолетний опыт, надежная продукция и инновационные технологии – все это характерно для конвейерных систем Рексрот. Наличие стандартизированных компонентов на складе позволяет существенно сократить время доставки.

Модульные элементы, которые могут использоваться в разном оборудовании, обеспечивают индивидуальные и настраиваемые под задачи заказчика решения. Такая высокая гибкость дает множество возможностей для комбинирования и сводит к минимуму необходимость накапливать запасные части.

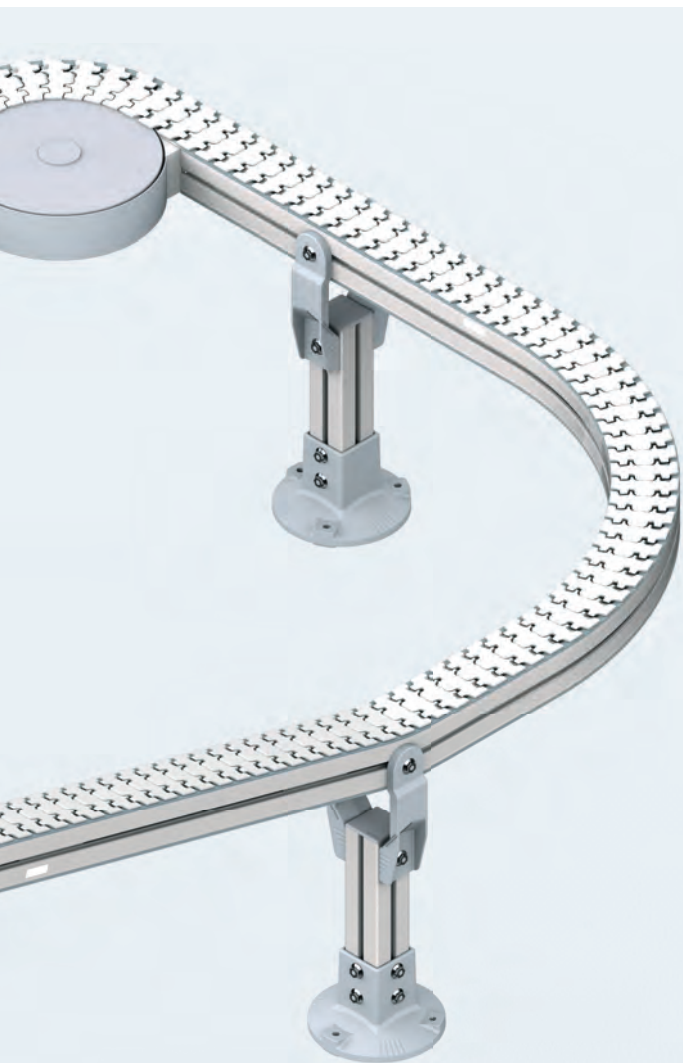

- ▶ Грамотное исполнение благодаря использованию опорного профиля для типоразмеров от 160 мм (вместо центрального профиля)



- ▶ Простая реализация восходящих и наклонных секций конвейера благодаря держателю с центрирующими кулачками, которые можно удалить
- ▶ Центровочный инструмент для дополнительных отверстий, для крепления поддонов, защитных устройств и т.д.



- ▶ Конфигурируемый комплект приводов (со стандартным мотор-редуктором или с интерфейсом, который выбирается заказчиком)
- ▶ Многоручевые системы/«альпийские» конвейеры реализуются благодаря поворотным секциям с колесом, на которые можно установить привод
- ▶ Возможность работы в реверсивном режиме



Для быстрой адаптации под ваши нужды предлагается ряд разных функциональных устройств:

- ▶ Автоматически регулируемые боковые направляющие
- ▶ Универсальное отводящее устройство
- ▶ Регулировочный блок для конвейеров с боковым захватом продукта
- ▶ Приводной мостик

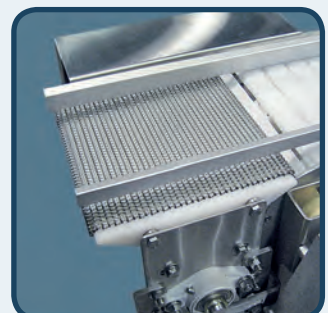

# Простое и быстрое планирование с помощью MТpro

MТpro – это интуитивно понятное программное обеспечение, которое используется для планирования конвейерных систем. Оно помогает вам на всех стадиях от выбора до конфигурирования и заказа необходимой продукции Рексрот

## Оптимальное проектирование конвейерных систем

Компоненты выбираются из базы данных с помощью обычного перетаскивания, быстро и просто собираются при помощи притягивания и соединения. Благодаря автоматическому расчету спецификации и наличию электронной ссылки для заказа, вы всегда можете контролировать свои расходы и минимизировать усилия. Различные интерфейсы позволяют использовать данные планирования для проектирования системы, закупки компонентов и их обслуживания.

## Планировать конвейерные системы стало проще

С MТpro вы можете спланировать, рассчитать и задокументировать свою конвейерную систему за несколько шагов. Интуитивно понятная концепция работы функции Layout Designer («проектировщик размещения») позволит вам очень быстро создать даже сложные конструкции и планировки систем.

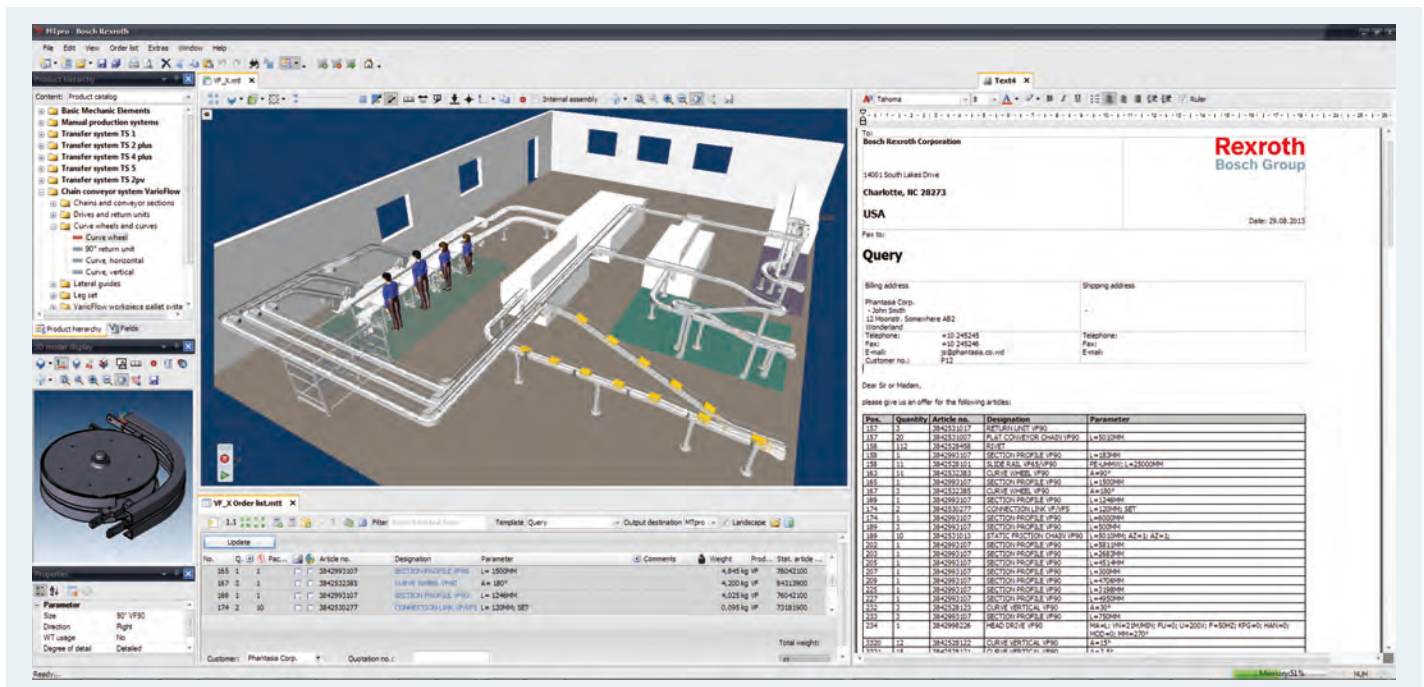

## Преимущества

- ▶ Все на виду: технические данные, информация о заказе, инструкции по сборке, модели САПР и иллюстрации запасных частей
- ▶ Интуитивно понятные комбинации компонентов для создания систем при помощи перетаскивания и соединения — без необходимости использовать систему САПР
- ▶ Оптимальные решения благодаря интегрированным средствам планирования и расчета, схожим с инновационной функцией MapModel
- ▶ Готовые спецификации, включая небольшие детали и аксессуары, по нажатию одной кнопки с электронной ссылкой для заказа
- ▶ Простота дальнейшей обработки планировок, данных САПР и данных по заказу

## Ключевые технические характеристики

- ▶ Электронный каталог продуктов и запасных частей по направлению «Сборочные технологии»
- ▶ Конфигурация продуктов и библиотека САПР с поддержкой всех широко распространенных форматов САПР
- ▶ Приложение «Layout Designer» для планирования рамных конструкций, рабочих мест и сборочных систем с расчетом спецификации
- ▶ MapModel: модель для симулирования зон доступа и визуальных полей, для проектирования эргономичных рабочих мест

## Нестандартные конструкции

- ▶ Конструкции рам и дополнительное оборудование в разделе «Базовые механические элементы»
- ▶ Планирование и эргономичное проектирование в разделе «Оборудование для организации рабочих мест»
- ▶ Планирование размещения цепных конвейеров и систем транспортировки

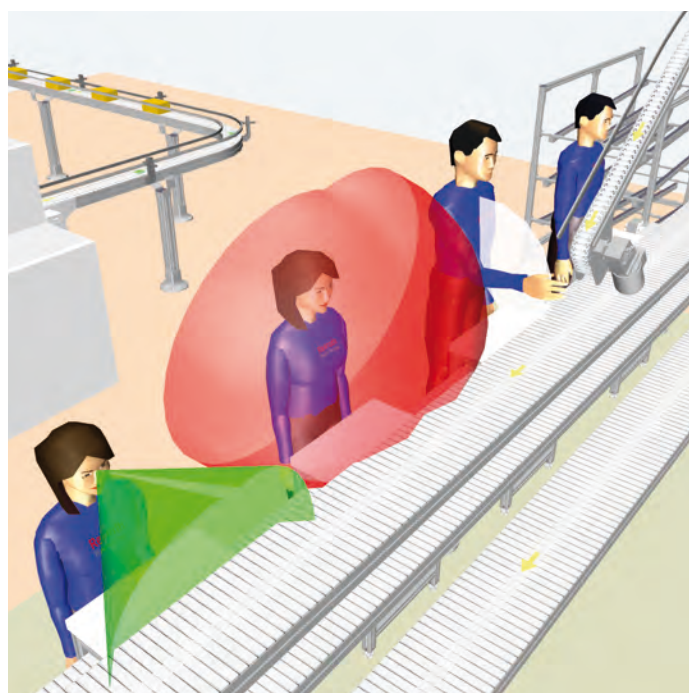
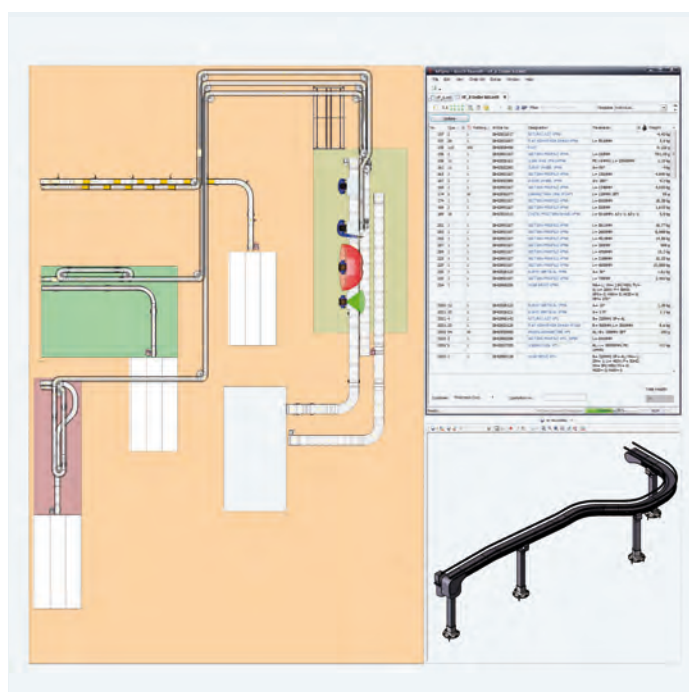



# Конвейерные технологии для высокопроизводительных гибких производственных систем

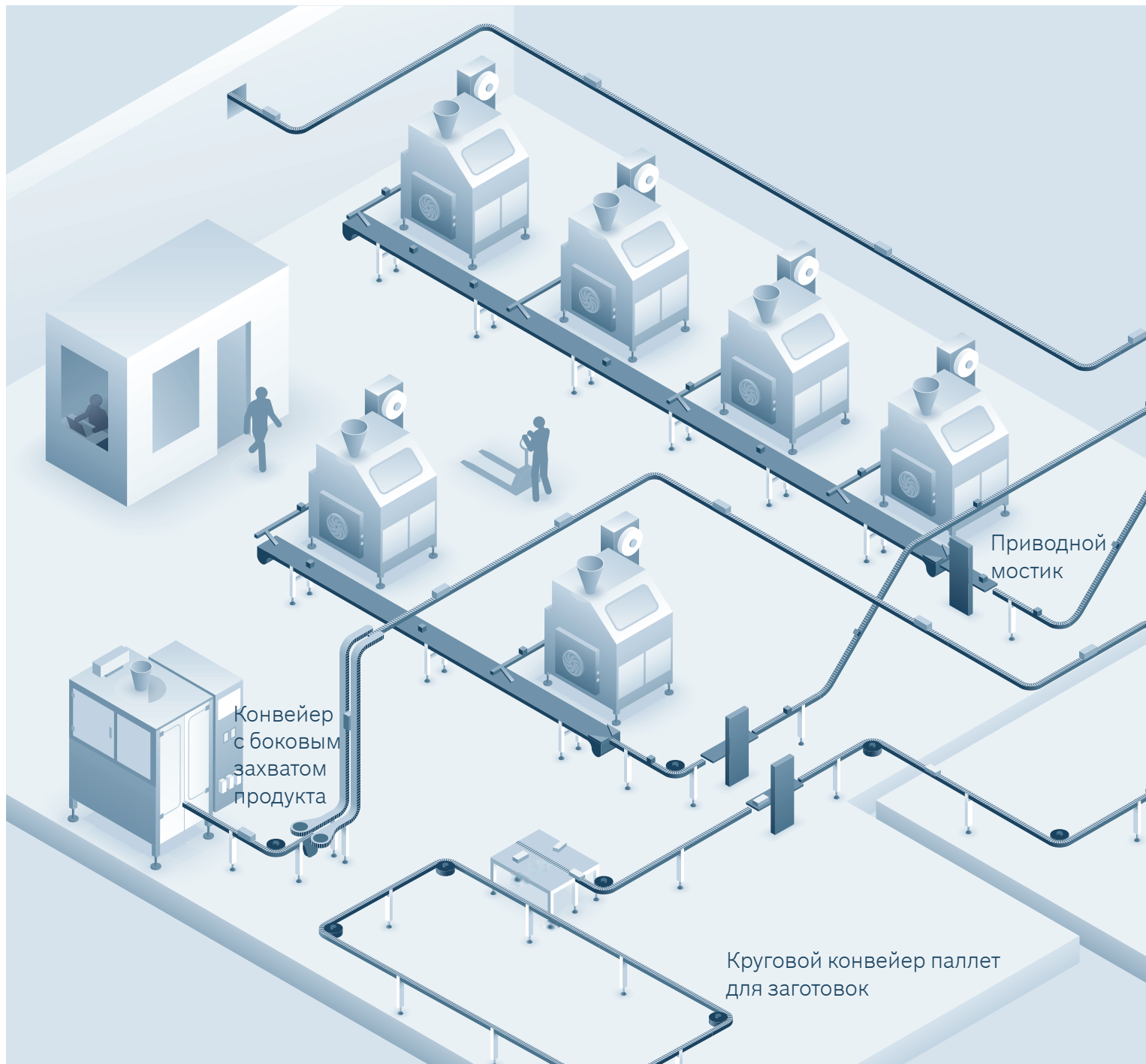

Конвейер с боковым захватом продукта



Паллета для заготовок



Приводной мостик

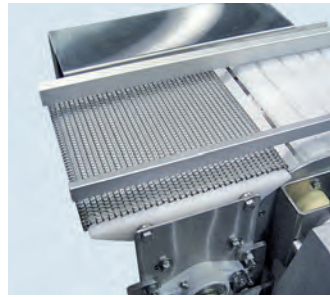

Альпийский («серпантинный») конвейер

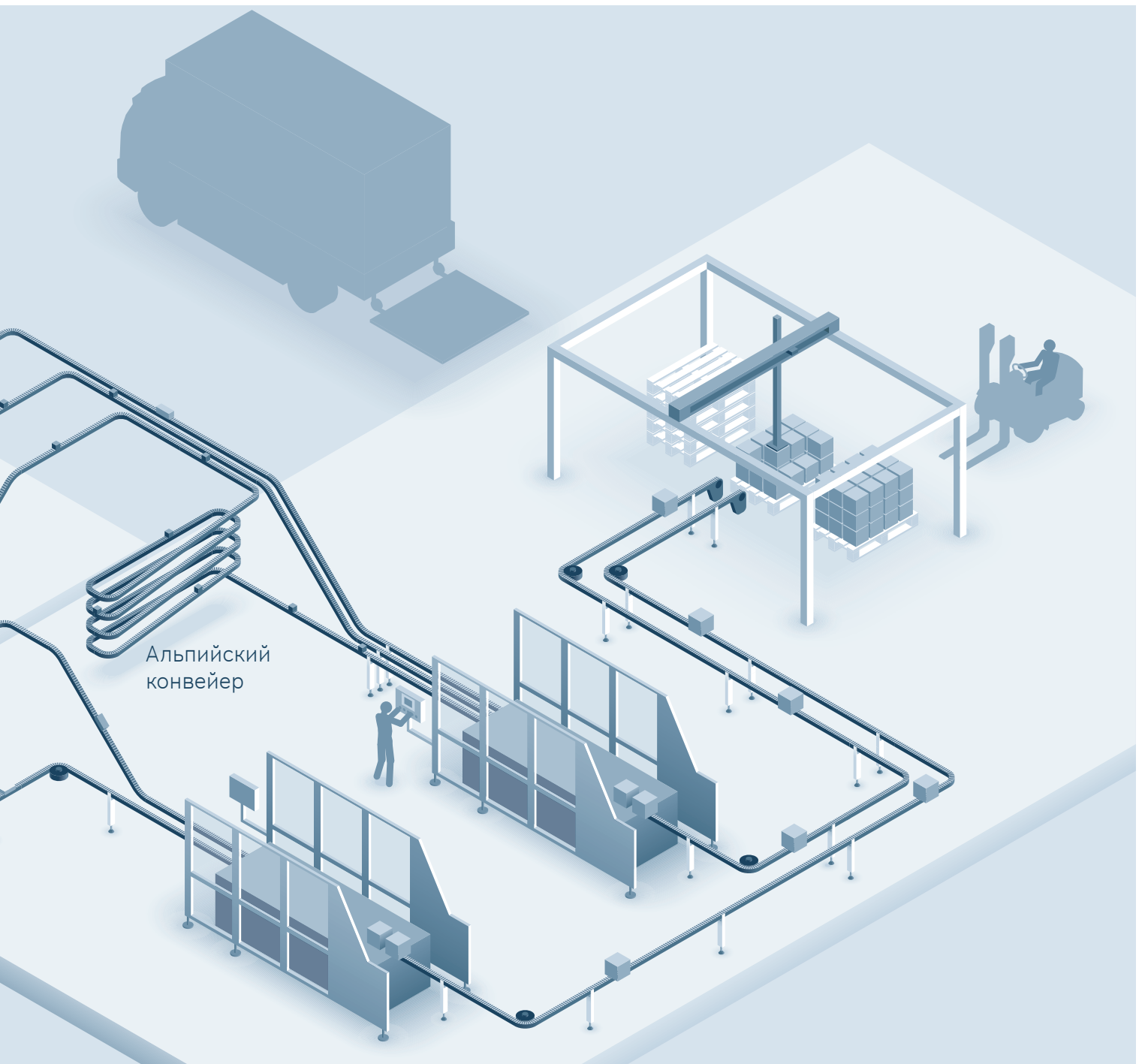
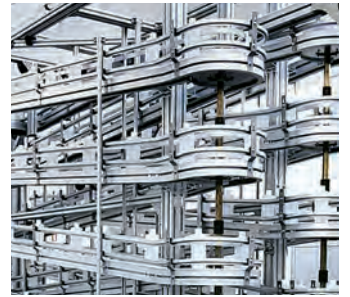

Альпийский конвейер



# Конвейерное решение для широкого ряда вариантов первичной упаковки

Конвейерная система Рексрот *VarioFlow plus* – решение для широкого спектра вариантов первичной упаковки, которое практически не требует технического обслуживания и отличается надежностью, гибкостью и большой производительностью. Стандартные компоненты позволяют размещать конвейеры в самых стесненных помещениях. Технические задачи, такие как безопасные переходы между конвейерами для мелких товаров, могут быть легко разрешены с использованием соединительных узлов.

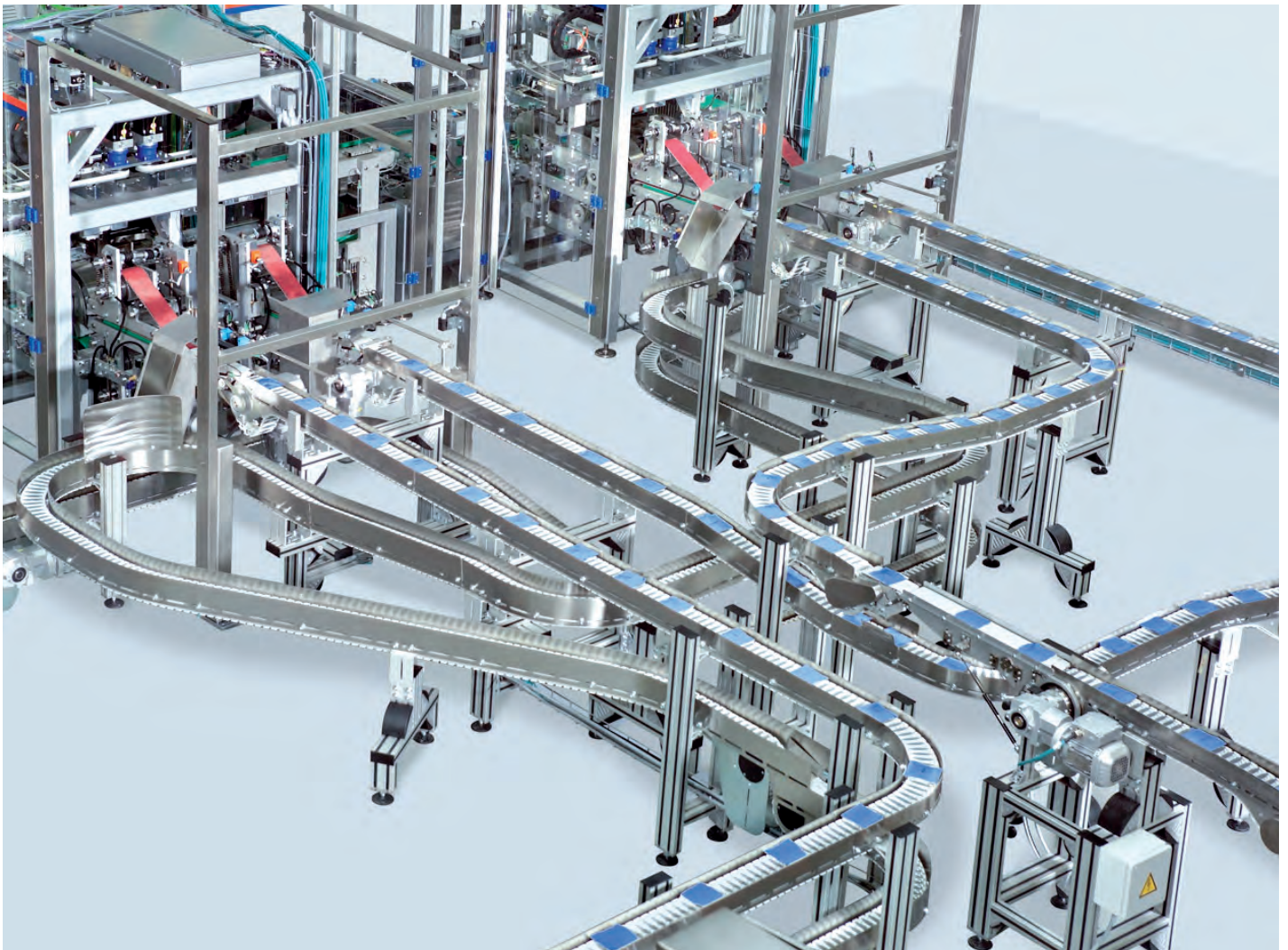



Формы, габариты и геометрия первичной упаковки определяются исключительно предпочтениями и требованиями заказчика. Специалисты по маркетингу выявляют эти потребности и реализуют их при проектировании первичной упаковки. VarioFlow *plus* можно использовать как для высоких и остроконечных бутылок для шампуня, так и для крупных вакуумных упаковок кофе. Конвейеры этой системы могут подстраиваться практически под любые требования и гарантировать безопасность транспортировки, распределения и сбора продукции.



- ▶ Возможность организации пересечений в самых стесненных условиях
- ▶ Стандартные компоненты из каталога продукции
- ▶ Модифицированные компоненты для оптимальных решений планирования



- ▶ Безопасное заполнение мостиками промежутков между ветвями конвейеров, в том числе, решения для продуктов сверхкомпактных размеров
- ▶ Установка приводных мостиков с передачей крутящего момента от приводных или натяжных станций системы конвейеров VarioFlow *plus*



## Конвейерные решения для вторичной упаковки

На пути к упаковочным машинам и от них важно обеспечить надежную, быструю и беспроблемную транспортировку вторичной упаковки разного размера и типа. *VarioFlow plus* предлагает ряд компонентов для непрерывных и надежных технологических цепей. Переходы для общего потока материалов во время производства выполняются при помощи восходящих, альпийских конвейеров или конвейеров с боковым захватом продукта.



В традиционных системах крупные или объемные изделия требуют поворотов большого радиуса с высоким коэффициентом трения. Рексрот использует другой подход: повороты с шариковыми подшипниками создают трение качения. Это означает снижение трения и износа, а также снижение потребности в энергии и увеличение допустимой нагрузки.



- ▶ Подходящие цепи для безопасной транспортировки или накопления продукции
- ▶ Скорость до 60 м/мин без добавления смазки
- ▶ Возможность регулировки скорости преобразователем и встроенным потенциометром

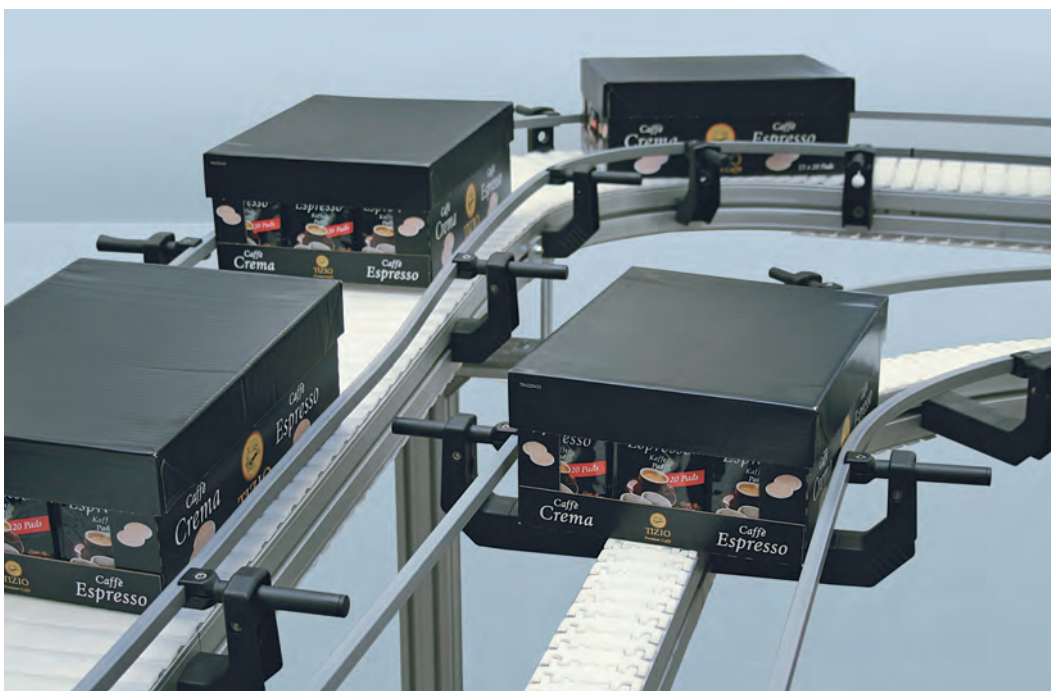

- ▶ Запатентованная технология шариковых подшипников позволяет выполнять транспортировку и накопление продуктов большого объема и веса даже при наличии поворотов в конвейере





# Решение по перекладке и транспортировке продукта для настраиваемой под нужды клиента окончательной упаковки

Рексрот предлагает умные решения для всех задач перемещения паллет. Картонная упаковка и лотки безопасно перемещаются многоосными порталными системами Рексрот с сервоприводами и точно размещаются и штабелируются на транспортной паллете согласно запрограммированной схеме размещения.

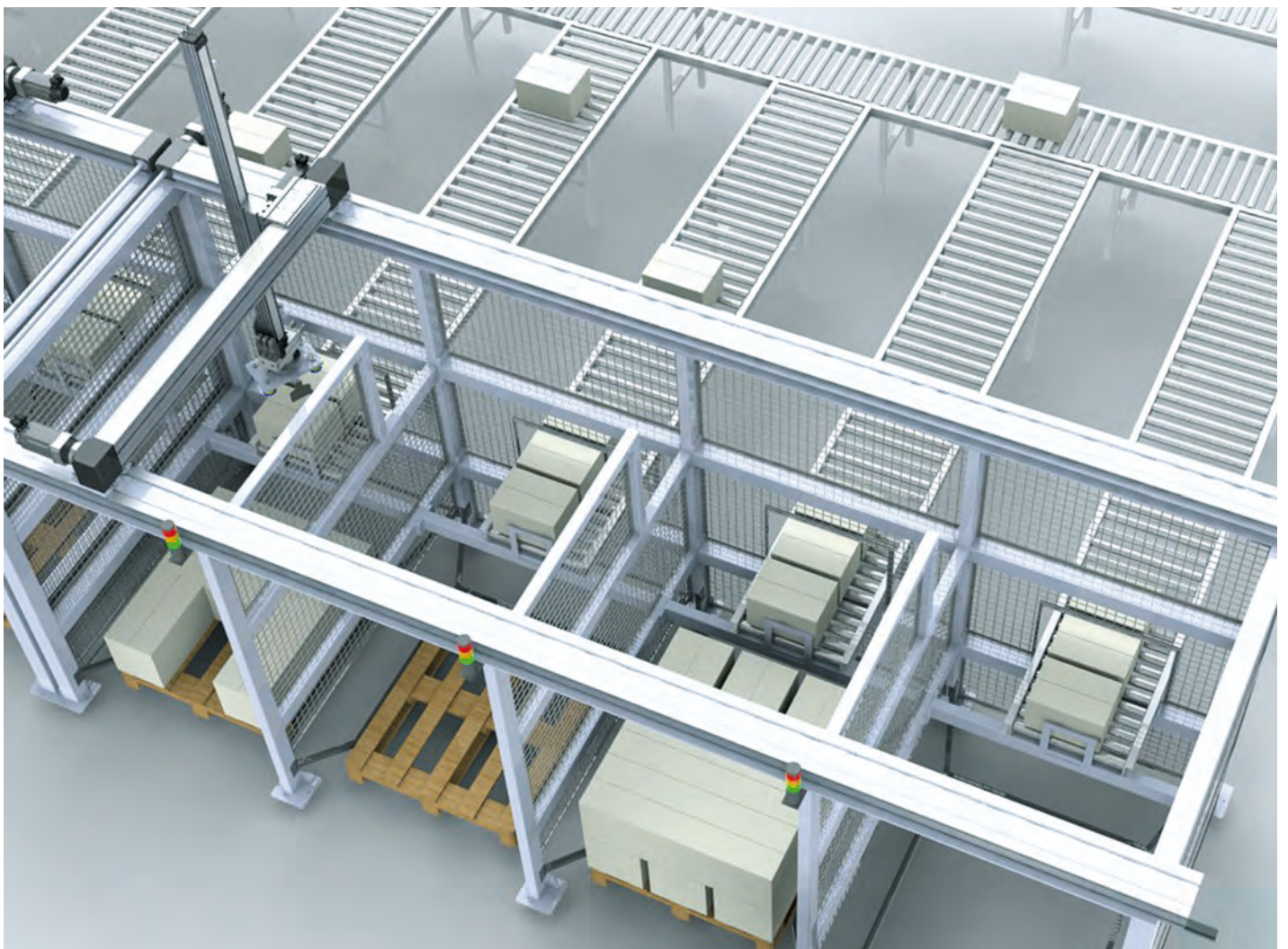



Существует множество вариантов окончательной упаковки, которые основаны на индивидуальных требованиях заказчика. Большие и маленькие семьи покупают удобную в употреблении упаковку, в то время как оптовикам нужны более крупные виды упаковки для крупных отгрузок.



- ▶ Решения для секций конвейеров с особыми требованиями к продуктам, например, ящики с открытым верхом и клапанами
- ▶ Транспортировка и накопление продукции на вертикальных и горизонтальных секциях конвейера



- ▶ Многосные модульные системы для динамического перемещения и высокой точности позиционирования с использованием ременного привода и валов
- ▶ Балки до 7 м с фиксированными концами
- ▶ Конфигурация на основе ПО

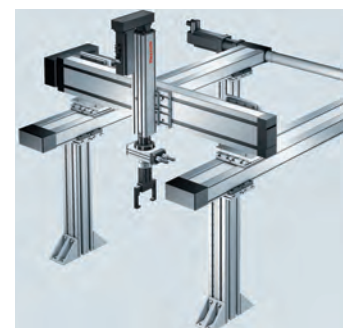



# Решение для сборочных производств

*VarioFlow plus* гарантирует точную транспортировку – непосредственно на самой цепи или на паллете. Системы перемещения паллет могут дополняться системами RFID для идентификации, хранения данных и управления потоками материалов.

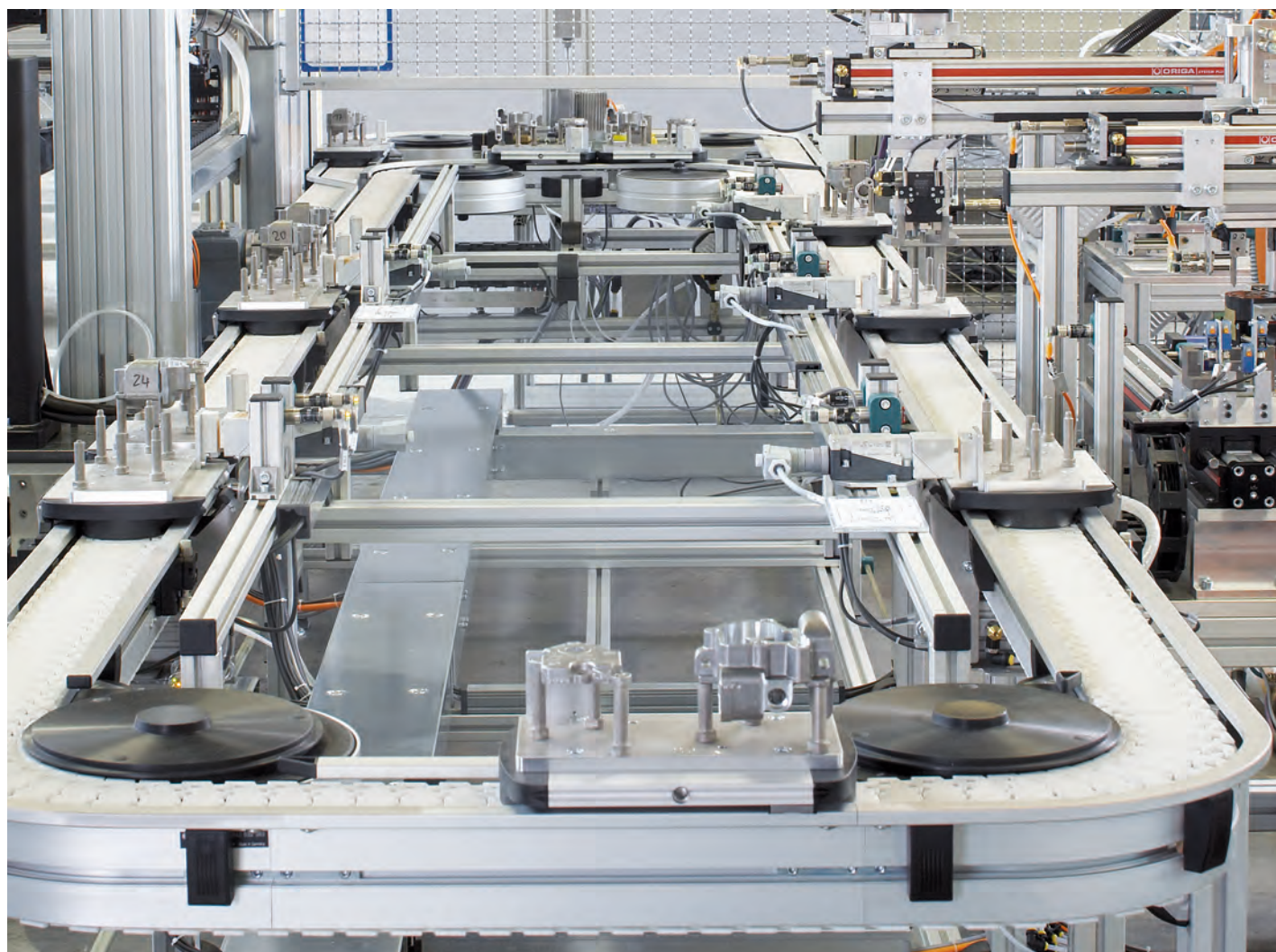



Что касается транспортировки деталей между разными производственными процессами, вне зависимости от того, являются ли эти станции полуавтоматическими, автоматическими или полностью ручными, системы перемещения паллет являются самым эффективным решением. Не имеет никакого значения, кто производит установку модульной системы перемещения паллет, сам заказчик или компания Бош Рексрот.



- ▶ Возможность расширения благодаря стандартизированным модульным блокам
- ▶ Простота технического обслуживания благодаря простой замене изнашиваемых деталей
- ▶ Согласованные компоненты, например, блоки позиционирования, диверторы, стопоры и направляющие
- ▶ Стандартизированная основа паллет шириной от 135 мм или 160 мм и длиной до 500 мм
- ▶ Точность позиционирования  $\pm 0,15$  мм

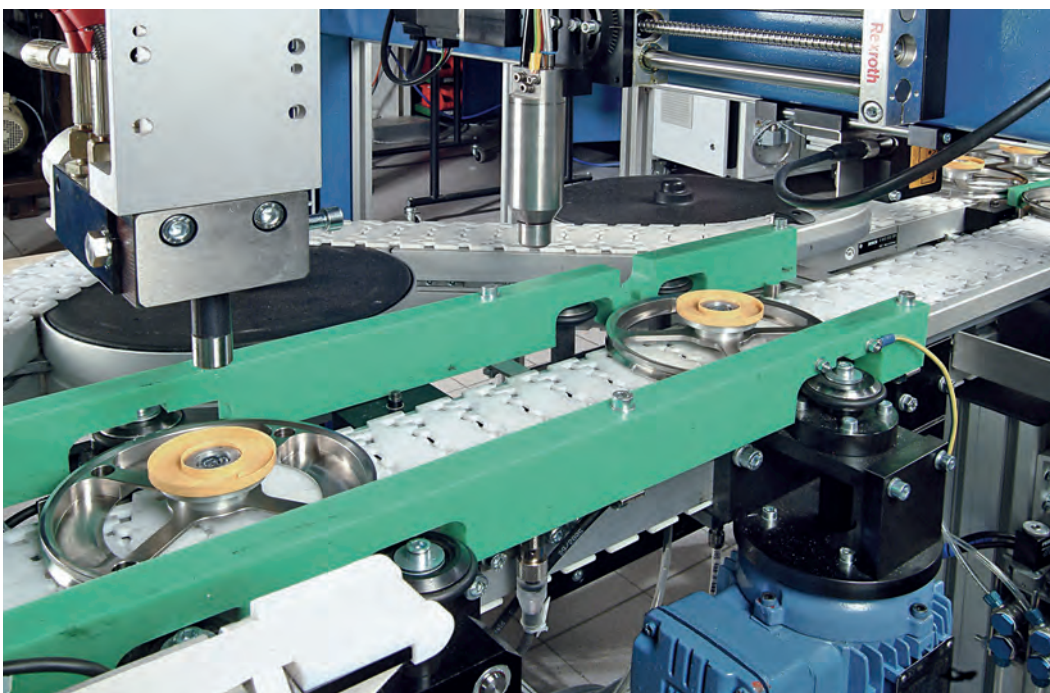



# VarioFlow *plus* как связующее звено между машинами

Эффективное решение для обеспечения связей между машинами — адаптируемость, надежность, простота обслуживания.





Даже учитывая наличие практически безотходных современных технологий для объединения машин, VarioFlow plus имеет преимущества ввиду использования материалов, стойких к воздействию разных сред. Использование в нижнем диапазоне нагрузок не требует таких же больших затрат, как в случае со старыми тяжелыми системами.



- ▶ Конвейерная система с низким уровнем шума
- ▶ Высокая надежность
- ▶ Возможность расширения благодаря стандартизированным модульным блокам
- ▶ Простота обслуживания и очистки
- ▶ Согласованные компоненты, например, блоки позиционирования, диверторы, стопоры и направляющие
- ▶ Может дополняться системой RFID (идентификации)



# Продукты и системы для цепных конвейеров

Будучи лидером рынка транспортных систем, мы также предлагаем ряд мощных компонентов, которые гарантируют непрерывный поток материалов в процессе производства – во всех сферах промышленности. Для конвейерных технологических систем Рексрот предлагает IndraLogic XLC, новый ПЛК, системы RFID (идентификации) для надежной регистрации процесса производства, а также экономичные и компактные преобразователи частоты, которые гарантируют энергоэффективность.

## Контроллер ПЛК IndraLogic XLC

Новая система ПЛК IndraLogic XLC (расширенный логический контроллер) основывается на новейших технологиях для ПЛК и гарантирует существенные преимущества для автоматизации производственных машин и систем.

## Преимущества для заказчика:

- ▶ Встроенное аппаратное обеспечение контроллера с возможностью расширения
- ▶ Встроенное ядро ПЛК IndraLogic 2G (на основании CoDeSys V3)
- ▶ Высокоэффективная связь за счет возможности подключения всех периферийных устройств по интерфейсу реального времени Ethernet sercos III
- ▶ Функция управления синхронизированным перемещением
- ▶ IndraWorks – один инструмент для всех инженерных задач

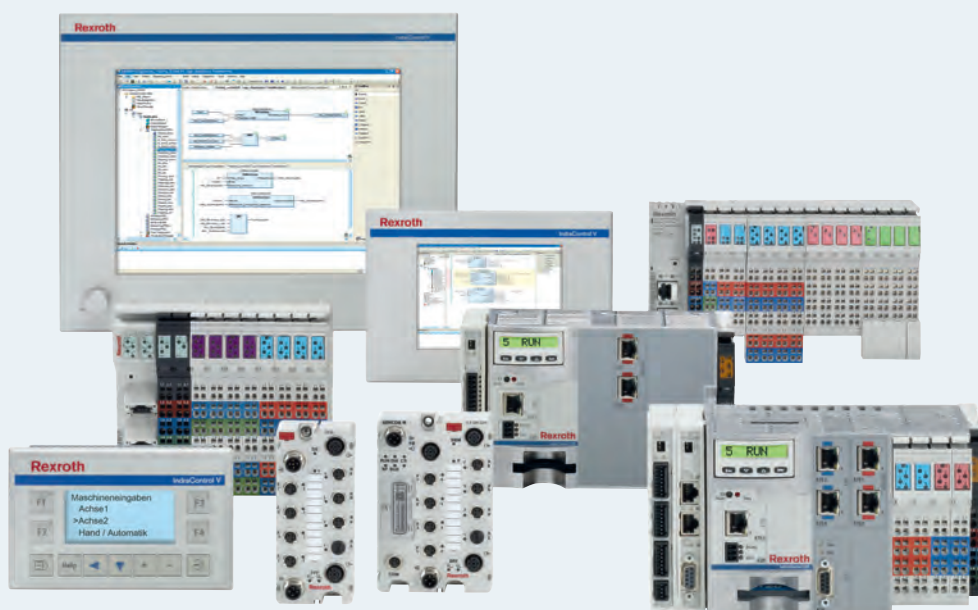

### Преобразователь частоты EFC 3600

Преобразователь частоты Рексрот EFC 3600 – это компактное экономичное энергоэффективное решение для приводов с мощностью от 0,4 кВт до 4 кВт. Простота пуска в эксплуатацию и монтажа позволяют использовать преобразователи для самых разных задач.

#### Преимущества для заказчика:

- ▶ Компактный и емкий: компактное исполнение с возможностью расположения в один ряд, со штепсельными разъемами ввода/вывода, с тормозным прерывателем и сетевым фильтром для упрощения установки
- ▶ Практичность: съемная панель оператора с функцией памяти, простым вводом параметров, гармонизацией параметров в рамках всей серии для экономии времени и повышения качества при пуске в эксплуатацию серии
- ▶ Максимальная энергоэффективность с минимальным уровнем шума благодаря возможности бесступенчатого регулирования частоты импульсов



### Системы RFID (идентификации)

Безопасное и надежное документирование данных с помощью идентификационным системам ID 200, ID 40 и ID 15. Мобильные ярлыки данных помещаются на паллеты конвейерной системы. Ярлыкам присваиваются уникальные идентификационные номера и, как вариант, данные о перемещаемых продуктах. Блоки чтения/записи общаются с системным контроллером посредством систем Ethernet или промышленных шин.

#### Преимущества для заказчика:

- ▶ Простота установки благодаря комплектам для монтажа высокой точности
- ▶ Компактное исполнение позволяет исключить необходимость в дополнительных мешающих контурах на паллете
- ▶ Различные интерфейсы для гибкого интегрирования в системный контроллер















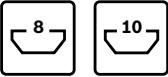









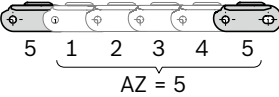



# Chain conveyor system *VarioFlow plus*

2.0



# Symbols

Presentation	Explanation									
	Components for the aluminum system (AL)									
	Components for the stainless steel system (STS)									
	<ol style="list-style-type: none"> <li>Profile with slot width 8 mm, 10 mm</li> <li>Accessories suitable for mounting to profiles with the specified slot width</li> </ol>									
	Conductive material version in accordance with DIN EN 61340-5-1; suitable for use in ESD-sensitive areas									
<table border="1"> <thead> <tr> <th>Section profile VFplus AL open</th> <th>L (mm)</th> <th>No.</th> </tr> </thead> <tbody> <tr> <td> 12 pcs</td> <td>6070</td> <td><b>3 842 546 647</b></td> </tr> <tr> <td>1 pcs</td> <td>50 ... 6000</td> <td><b>3 842 996 026/L</b></td> </tr> </tbody> </table>	Section profile VFplus AL open	L (mm)	No.	 12 pcs	6070	<b>3 842 546 647</b>	1 pcs	50 ... 6000	<b>3 842 996 026/L</b>	<p>Delivery unit  = delivery quantity (here: 12 items)</p> <p>Order: 1 x 3 842 546 647:                      Delivery: 12 x section profile VFplus AL open, L = 6070 mm                      11 x 3 842 546 647:                      Delivery: 132 x section profile VFplus AL open, L = 6070 mm</p>
Section profile VFplus AL open	L (mm)	No.								
 12 pcs	6070	<b>3 842 546 647</b>								
1 pcs	50 ... 6000	<b>3 842 996 026/L</b>								
<table border="1"> <thead> <tr> <th>Cross connector AL</th> <th>b (mm)</th> <th></th> <th>No.</th> </tr> </thead> <tbody> <tr> <td>VFplus 65</td> <td>65</td> <td>10</td> <td><b>3 842 546 672</b></td> </tr> </tbody> </table>	Cross connector AL	b (mm)		No.	VFplus 65	65	10	<b>3 842 546 672</b>	<p>Packing unit  = minimum order quantity (here: 10 items)</p> <p>Order: 1 x 3 842 546 672:                      Delivery: 10 x 3 842 546 672 (rounded up)                      15 x 3 842 546 672:                      Delivery: 20 x 3 842 546 672 (rounded up)</p>	
Cross connector AL	b (mm)		No.							
VFplus 65	65	10	<b>3 842 546 672</b>							
	<p>Distance, in which the “special chain links” are inserted between the flat chain links.</p> <p>AZ = spacing distance</p> <p>Example:                      AZ = 5 = a special chain link follows four flat chain links</p>									

<b>Introduction VarioFlow plus, System overview</b>			<b>4</b>	<b>1</b>
<b>Conveyor chains</b>			<b>16</b>	<b>2</b>
<b>VarioFlow plus Aluminum system (AL)</b>			<b>48</b>	<b>3</b>
<b>VarioFlow plus Stainless steel system (STS)</b>			<b>120</b>	<b>4</b>
<b>VarioFlow plus ESD system</b>			<b>170</b>	<b>5</b>
<b>Wedge conveyor</b>			<b>190</b>	<b>6</b>
<b>Lateral guide</b>			<b>198</b>	<b>7</b>
<b>Workpiece pallet system (WT)</b>			<b>220</b>	<b>8</b>
<b>Tools</b>			<b>262</b>	<b>9</b>
<b>Technical data</b>			<b>268</b>	<b>10</b>
<b>Material number overview</b>			<b>300</b>	<b>11</b>
<b>Index</b>			<b>302</b>	<b>12</b>



# VarioFlow *plus* – the innovative chain conveyor system, easily installed, with low-noise operation

Today, customer requirements for transport solutions are more demanding than ever. With the VarioFlow *plus* Rexroth offers a powerful, standardized, and versatile conveyor system for use in the food & packaging industries, health care, assembly lines in automotive & electronics, and machine linking.





The modular Rexroth VarioFlow *plus* chain conveyor system consists of components that can be used universally for all system widths. This reduces the parts that must be stocked by the user.

The stable chain permits tensile forces of up to 1,250 N. The chain surface is nearly closed, allowing even the smallest of parts to be transported safely and reliably.

The concept for individual section routing comprises the sizes 65, 90, 120, 160, 240, and 320 in two materials: the basic aluminum version and the stainless steel version for applications with higher hygiene requirements, such as in the food industry. For this, Rexroth uses components made of FDA-compliant materials.

Alternatively, Rexroth offers a workpiece pallet system suitable for transporting workpiece pallets in the automotive and electronic industries.



# The advantages of VarioFlow *plus*

## Flexible planning and rapid commissioning thanks to intelligent solutions

The clever drive solution enables a great degree of planning freedom: the motor mounting position can be selected

on-site. Smart connection technology saves time during assembly and allows for easy conversions and system extensions.

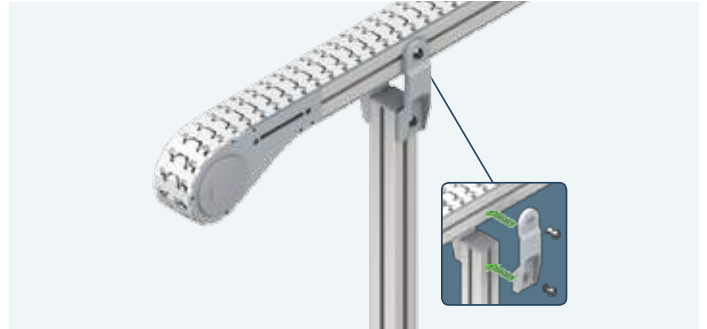
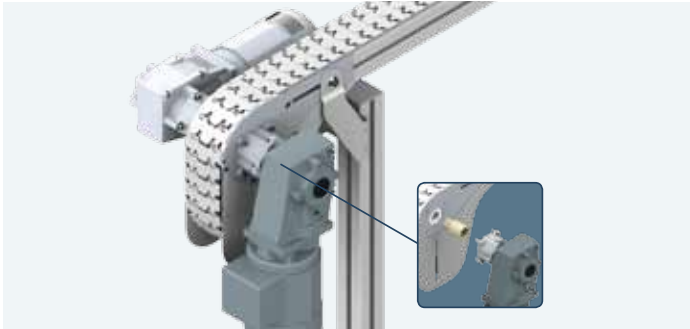

## Optimal work conditions thanks to quiet operation and easy maintenance

The maintenance-friendly conveyor system VarioFlow *plus* creates ideal conditions at the workstation. Thanks to improved sliding properties and low friction materials, the working environment is relatively quiet (see page 294).

Fewer joints and the rolling friction in the horizontal curves ensure low wear and thus reduce downtimes.

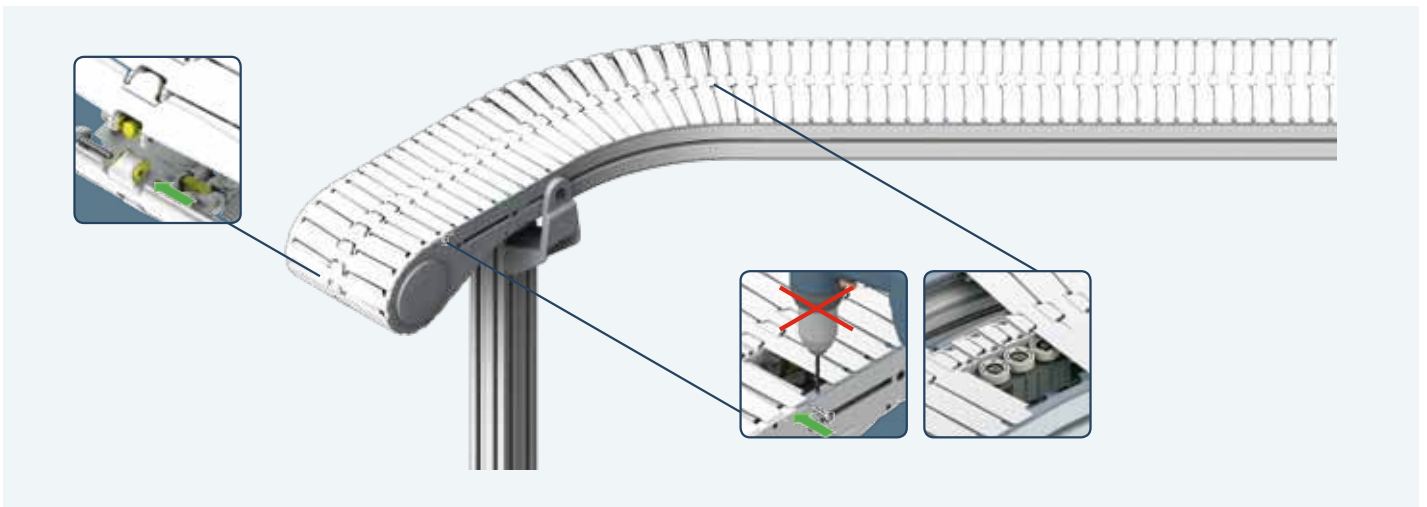



## Simple and fast project planning with MTpro

MTpro is an intuitive software program used for planning assembly systems. It assists you from selection to configuration and ordering of the Rexroth products. Components can be selected from the range via drag & drop and assembled quickly and easily using the snap function. Thanks to the automatic bill of material calculation and electronic order integration, you can keep costs under control and minimize your ordering effort.

Numerous interfaces enable the planning data to be subsequently used in the areas of Construction, Purchasing, and Service.

With MTpro you can plan, calculate, and document your assembly systems in just a few steps. The Layout Designer lets you create even complex constructions and system layouts in no time at all.

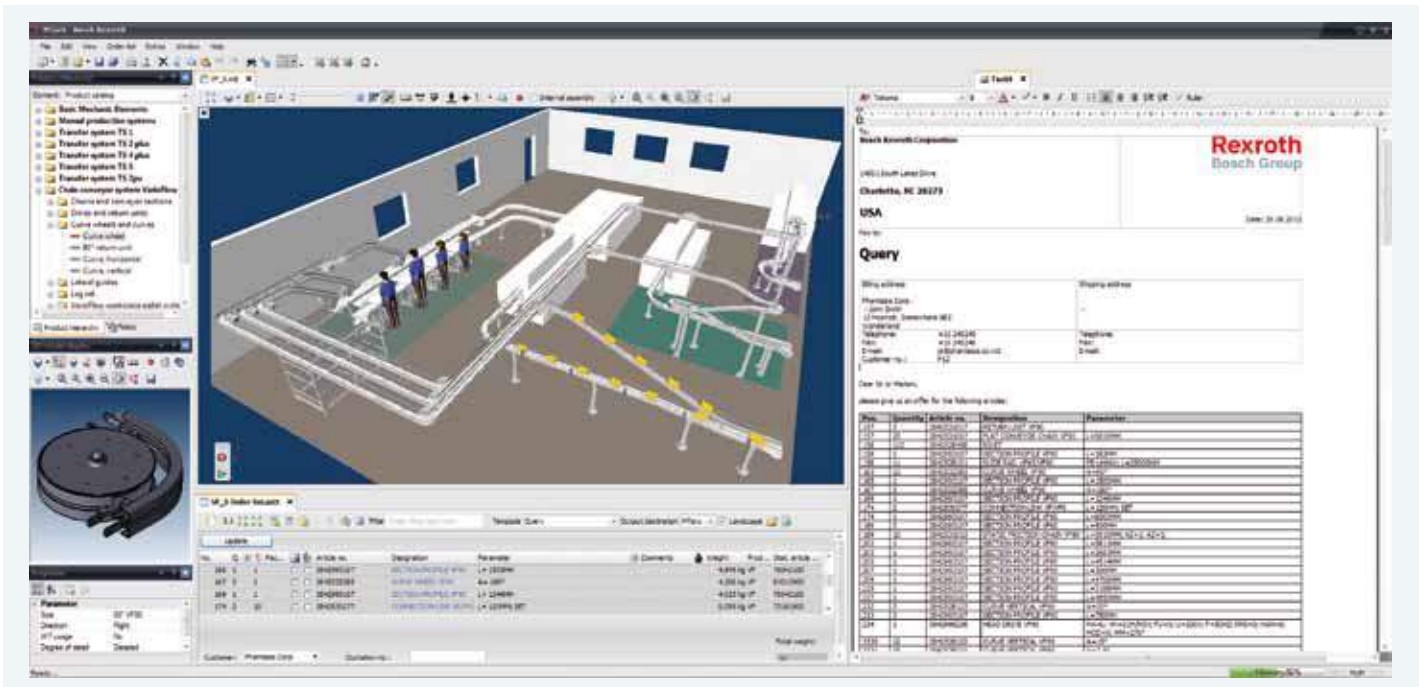

# VarioFlow plus – for the economical, individual transport of parts

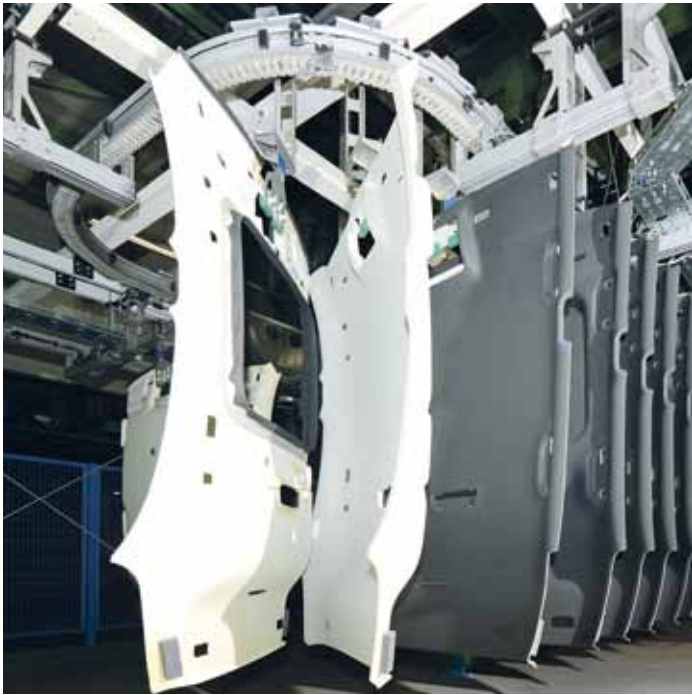









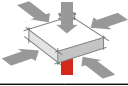
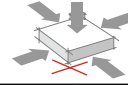

# Useful information for selecting and designing a chain conveyor system

## Chain conveyor or transfer system

	<b>TS1</b>	<b>TS2 plus</b>	<b>VarioFlow</b>	
Typical applications	Linking assembly stations and assembly workstations 		Horizontal and vertical product transport 	
Speed	4.5–18 m/min	4.5–18 m/min	4–60 m/min	4–18 m/min
Workpiece pallet size (from ... to)	80x80 mm ... 160x160 mm	160x160 mm ... 1200x1200 mm	Direct transport without workpiece pallet	65x76 mm ... 90x500 mm
Product weight	3 kg	240 kg	3 kg/34.5 mm	8 kg <b>with</b> function modules (diverter, positioning unit, etc.) 15 kg <b>without</b> function modules (diverter, positioning unit, etc.)
Accessibility				
Section path				
Positional accuracy	0.015 mm	0.1 mm	0.15 mm	0.15 mm

## Aluminum or stainless steel version

### Requirements

Harsh, normal (emulsions)	← Ambient conditions →	Clean
Yes	← Food and Drug Administration →	Yes
Yes	← Electrostatic discharge →	No
Alcohol, water  ↓ <b>Aluminum</b>	← Cleaning agents →	Wet cleaning/ use of acid-containing or alkaline cleaning agents (pH value: 5 to 8)  ↓ <b>Stainless steel</b>

## Direct transport or workpiece pallet transport

The center of gravity location, inherent stability, and the contour of a product determine whether direct transport on a chain conveyor system is suitable or a workpiece pallet is required.

Workpiece pallets can be used when:

- The product has no static stability due to its geometry
- Transport can cause a change in position of the product
- The process requires it
- The product surface is very sensitive
- Accumulation is required and the product geometry does not allow for accumulation
- An exact positioning of the part is required
- The process is controlled via an ID system

## Track width

The selection of the chain conveyor system width is determined by the nature of the product and its dimensions. The maximum width of the conveyed goods is dependent on the form and location of its center of mass. If products are transported directly, the system width can differ greatly from the product width. It is important for direct transport that the center of the product is as close as possible to the center of the chain and that it has high inherent stability.

## System height

The stainless steel (STS) and aluminum (AL) versions have the same system height.

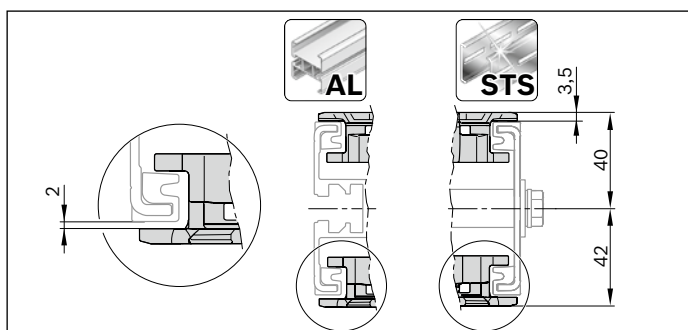

## Load and chain tensile force

With the *BKBsoft* chain calculation program, which is integrated into the *MTpro* planning software, the maximum chain tensile force and required drive torque can be calculated quickly and efficiently.

If the approved chain tensile force or drive torque of the gear motor is exceeded, the layout of the conveyor section should be checked to see whether it can be adjusted. This can be done by dividing the conveyor section, reducing the speed, shortening accumulation sections, or using curve wheels or roller curves instead of sliding curves. See also the section Stick-slip effect on page 274.

## Ambient conditions

### Abrasive ambient conditions:

When fitting the chain conveyor, pay special attention to the cleanliness of the slide rails and the section profile. Metal shavings and builder's dust are very abrasive and can cause extreme wear!

During operation, general cleanliness of the system and its environment should be emphasized. This will prolong the service life of slide rails and chains. Dust and dirt particles, as well as chippings, salt, sugar, etc., are also very abrasive.

Using a chain conveyor system in critical environments is to be checked in each individual case. Please contact your Rexroth representative.

### Temperature:

The area of application for *VarioFlow plus* is 0 °C to < 60 °C. Temperatures < 0 °C require special gear motors with special lubrication, seals, and ball bearings (available on request).

Temperatures > 40 °C reduce the performance of drive motors and increase the stretching of plastics. This results in a lower chain tensile force. See also section "Technical data" on page 274.

### Media resistance:

The materials used are resistant to most chemicals used in industrial applications. See also "Resistance of the chain against chemicals" on page 296.

If in doubt, it is recommended that you ask the manufacturer of the cleaning agent whether the VF material (see material use) is resistant to the cleaning agent.

A resin in the lubricant oil can bond the chain to the slide rail after longer downtimes. You can remedy this by continual (empty) runs or by cleaning with a normal emulsion on completion.

### Humidity:

Operating the *VarioFlow plus* in dry rooms is not permitted; the relative air humidity must be at least 5%.

### High-pressure cleaning:

High-pressure cleaning of the chain conveyor ball-bearing areas (e.g. in the drive, roller curves, etc.) is prohibited.



# System overview

The modular system with a few basic building blocks in six track widths and two materials enables a transport system to be adapted to the most diverse requirements.

The system components are available in aluminum (AL) as a basic version or in stainless steel (STS) for increased hygiene requirements (e.g. in the food industry). The ESD system comprises AL, STS and special ESD components.

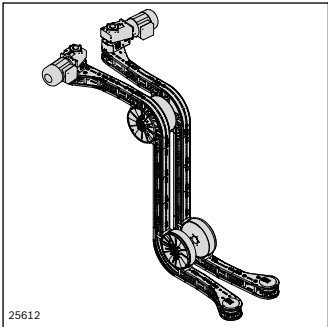
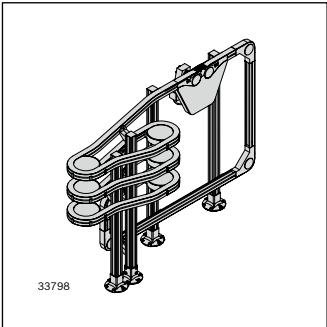
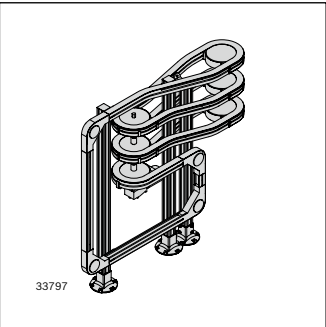
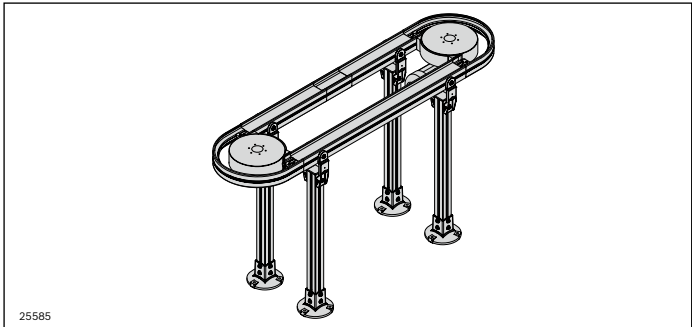
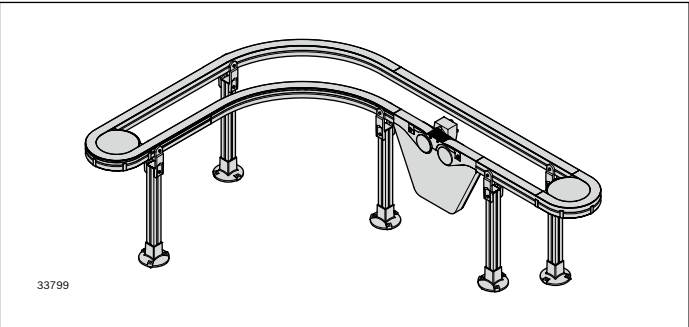
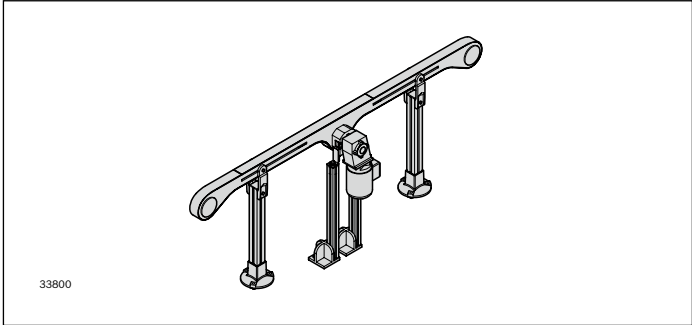
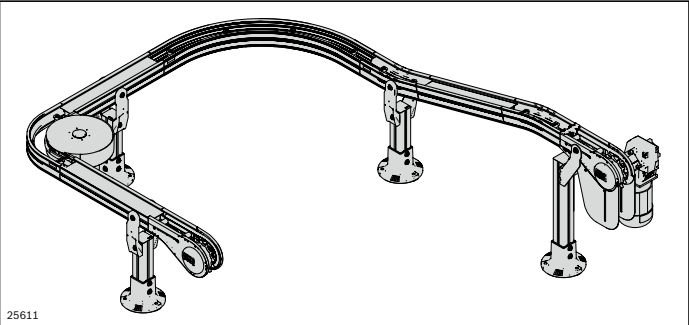

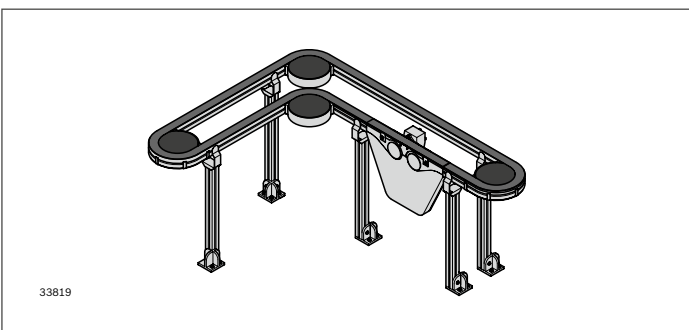
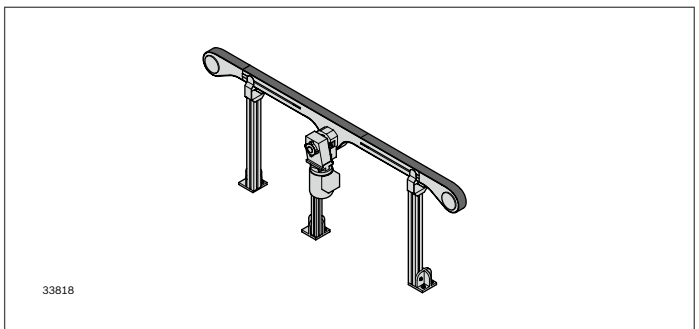
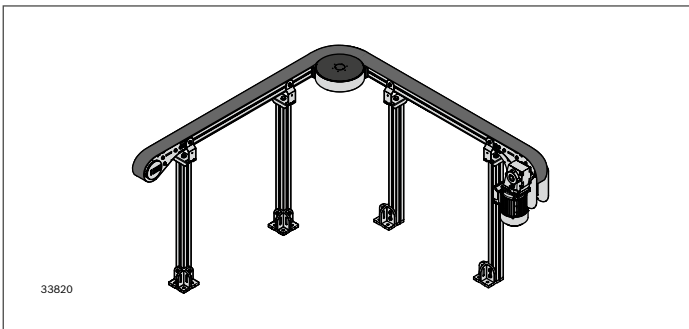
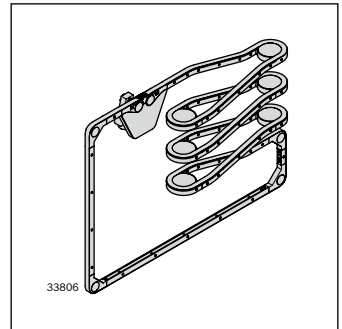
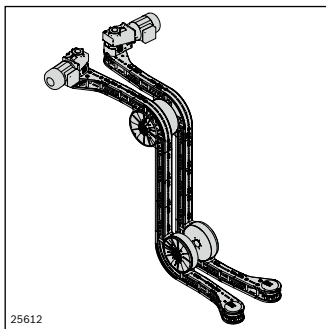
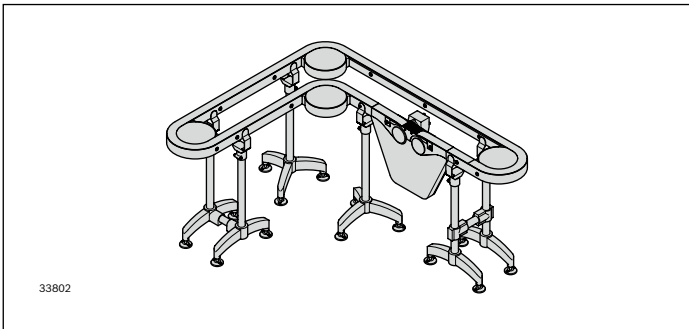
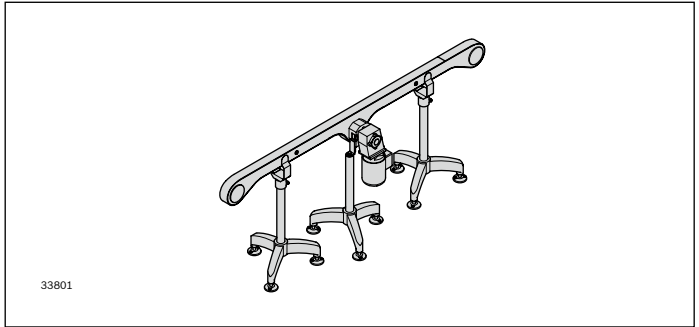
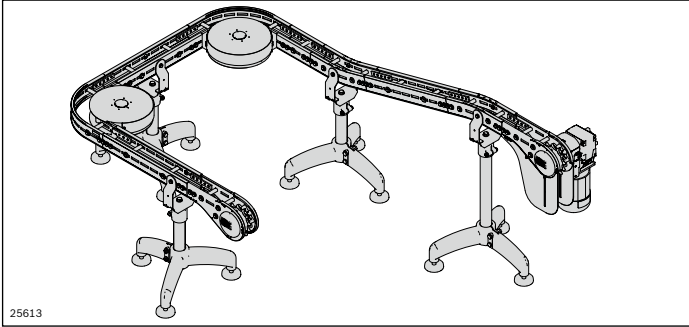

# GoTo Europe Preferential program

No sooner ordered than delivered

1

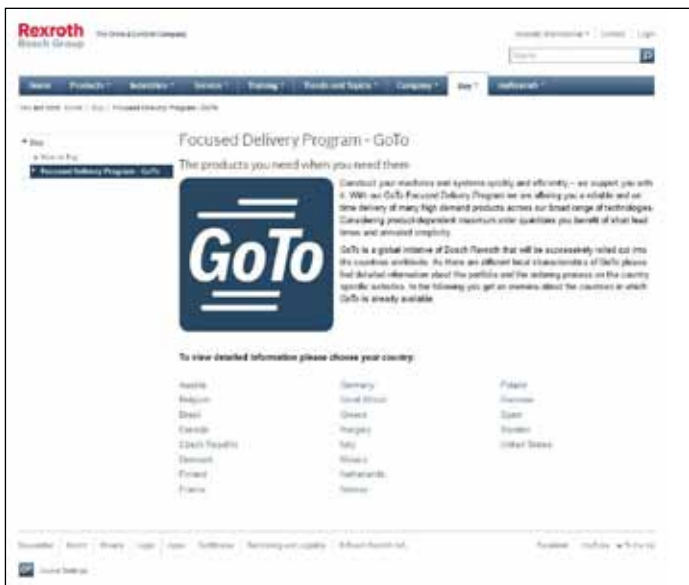

The GoTo preferential program offers a targeted selection of our most common products by means of a preferential service: As a result, you receive your products quickly and reliably, allowing you to respond to your market and customer requirements at any time.

### Your advantages

- ▶ Reduced inventory and capital due to short and reliable delivery times
- ▶ Flexible response to customer and market requirements through high availability of many products
- ▶ Simple, quick ordering via e-mail, fax, mail, or eCommerce at Bosch Rexroth or its sales partners

### Online

Visit the website for the preferential program. It offers simple access to additional product information, including data sheets, part numbers, specifications, downloads and more.

[www.boschrexroth.com/goto](http://www.boschrexroth.com/goto)





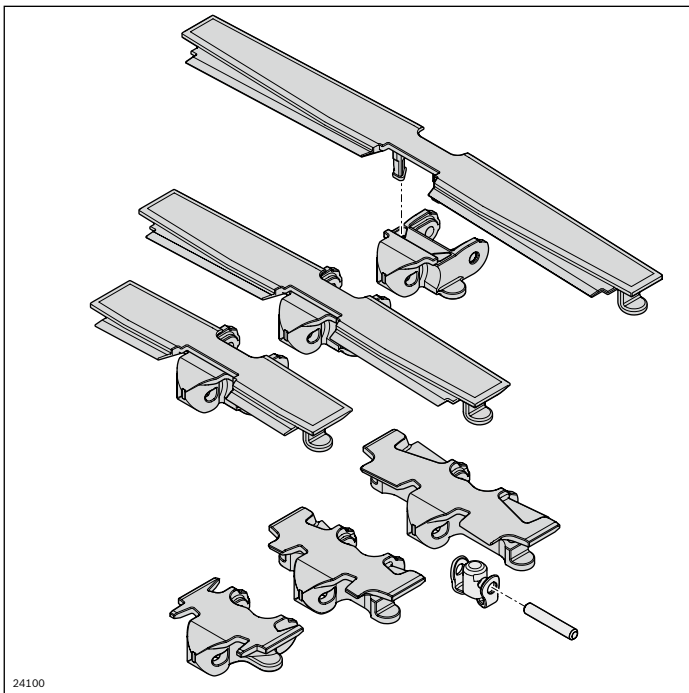







# Conveyor chains



- ▶ Optimized antifriction properties of the chains
- ▶ Chain links uncoupled by means of different materials (patented)
- ▶ FDA-compliant materials
- ▶ Low-vibration transport of small parts and accumulation operation possible thanks to covered chain links
- ▶ Easy-to-exchange chain plate from size 160
- ▶ Wide variety of chain types suitable for different applications

Quiet and smooth-running parts transport thanks to patented conveyor chains

	<b>Flat conveyor chain</b>	<b>18</b>
	<b>Static friction chain</b>	<b>22</b>
	<b>Accumulation roller chain D11, Roller cleat chain D11</b>	<b>26</b>
	<b>Roller cleat chain D20</b>	<b>30</b>
	<b>Roller cleat D35</b>	<b>32</b>
	<b>Cleated chain</b>	<b>36</b>
	<b>Universal chain</b>	<b>38</b>
	<b>Steel-coated chain</b>	<b>42</b>
	<b>Flocked chain</b>	<b>44</b>
	<b>Clamping chain</b>	<b>46</b>

## Flat conveyor chain

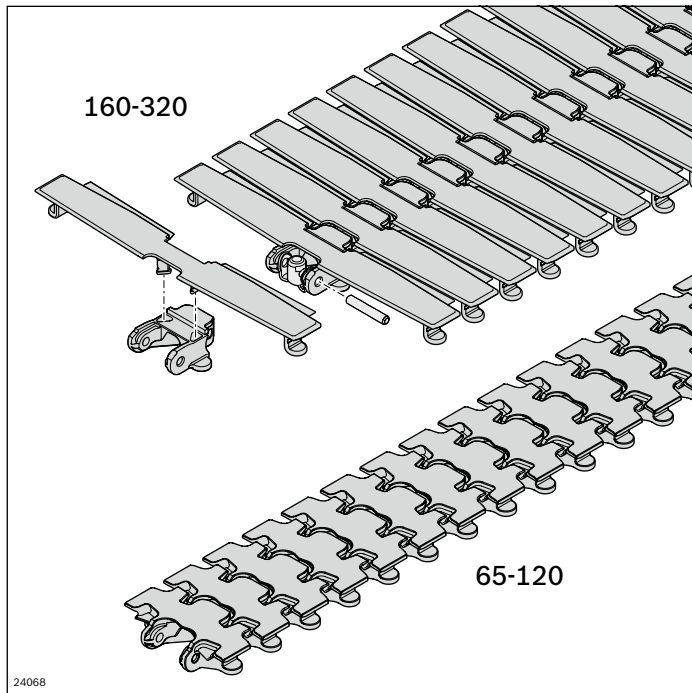

- ▶ Drilling the flat chain links allows for the simple attachment of superstructures. Sizes 65-120 have a mold cavity for accommodating a flat M5 hexagon nut. Sizes 160-320 have a centering aid mounted on the underside of the chain plate. Max. drilling up to  $\varnothing 5$  mm, since at this point there are no interfering contours in the chain conveyor, see page 21

### Required accessories for individual chain links:

Chain pin and jointed bolts, see page 19

For basic chain links 160-320, a chain plate is also required, see p. 20, 21

### Optional accessories:

- Static friction chain link, see p. 22
- Accumulation roller chain link D11, see p. 26
- Roller cleat chain link D20, see p. 30
- Cleated chain link, see p. 36
- Universal chain link, see p. 38

The flat conveyor chain is used to transport products directly or indirectly via workpiece pallets.

The gray conveyor chain is mainly used to transport products indirectly via workpiece pallets, in particular for steel wear pads. The dark coloring means that there is virtually no visual impairment of the chain surface.

- Transport on ascending or descending sections up to  $7^\circ$  possible, depending on the product (test required)
- Accumulation operation permitted, depending on the product
- Maximum chain tensile force: 1250 N
- From size 160: Chain plate easy to replace
- Size gray chain: 65, 90
- Chain links can be combined with other types of chains of the same size
- Chain also available in ESD version, see ESD conveyor chain on page 176

- ▶ Extremely quiet chain running thanks to the patented chain design
- ▶ Materials meet the requirements of EU 10/2011 and FDA CFR 21 (does not apply for conveyor chain gray)

### Scope of delivery:

Chain: Complete, incl. chain pin and jointed bolts

### Condition on delivery:

Chain: Fully assembled

### Material:

- Chain link: POM
- Chain plate: POM
- Chain pin: Stainless steel, 1.4301
- Jointed bolts: PA66



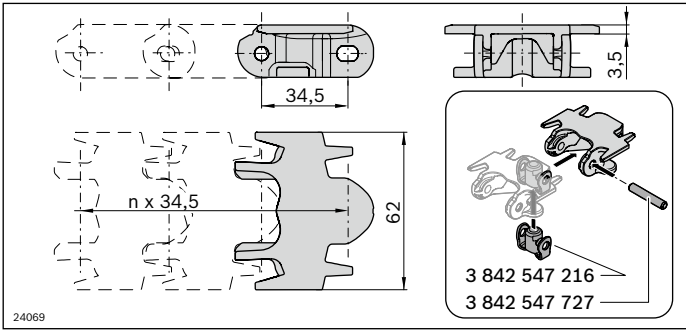

<b>Flat conveyor chain VFplus 65</b>	<b>L (mm)</b>	<b>No.</b>
Conveyor chain	4968	1 <b>3 842 546 069</b>
Chain link	10	<b>3 842 546 000</b>
Conveyor chain, gray	4968	1 <b>3 842 546 075</b>
Chain pin	100	<b>3 842 547 727</b>
Jointed bolt	100	<b>3 842 547 216</b>

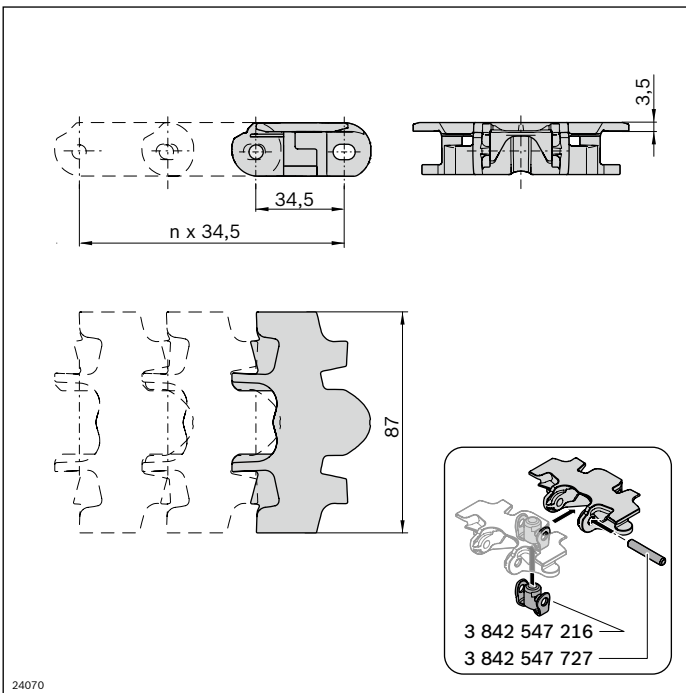

<b>Flat conveyor chain VFplus 90</b>	<b>L (mm)</b>	<b>No.</b>
Conveyor chain	4968	1 <b>3 842 546 070</b>
Chain link	10	<b>3 842 546 001</b>
Conveyor chain, gray	4968	1 <b>3 842 546 076</b>
Chain pin	100	<b>3 842 547 727</b>
Swivel pin	100	<b>3 842 547 216</b>

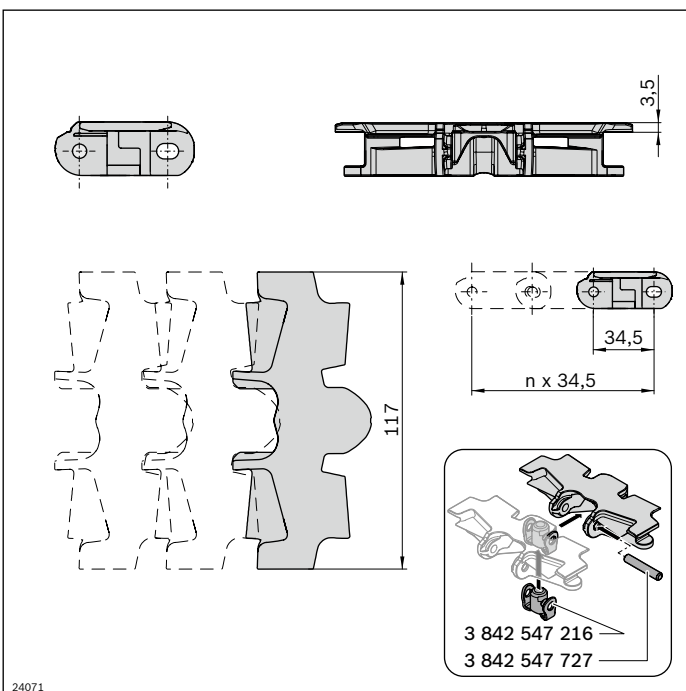

<b>Flat conveyor chain VFplus 120</b>	<b>L (mm)</b>	<b>No.</b>
Conveyor chain	4968	1 <b>3 842 546 071</b>
Chain link	10	<b>3 842 546 002</b>
Chain pin	100	<b>3 842 547 727</b>
Swivel pin	100	<b>3 842 547 216</b>

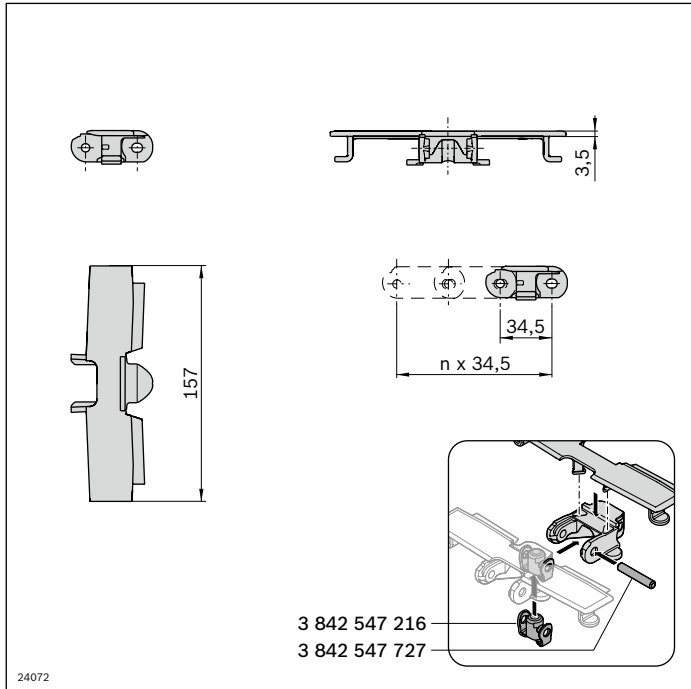

<b>Flat conveyor chain VFplus 160</b>	<b>L (mm)</b>		<b>No.</b>
Conveyor chain	2898	1	<b>3 842 546 072</b>
Basic chain link 160-320		10	<b>3 842 546 028</b>
Chain plate 160		10	<b>3 842 546 093</b>
Chain pin		100	<b>3 842 547 727</b>
Swivel pin		100	<b>3 842 547 216</b>

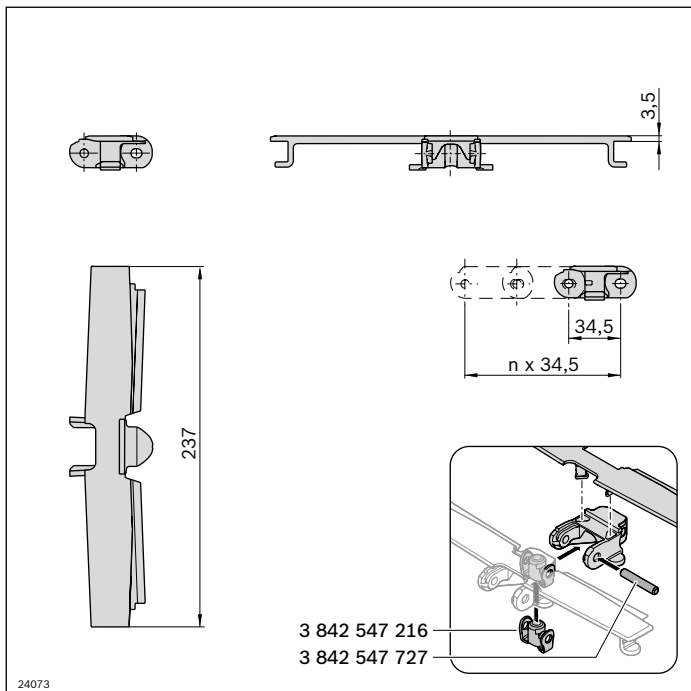

<b>Flat conveyor chain VFplus 240</b>	<b>L (mm)</b>		<b>No.</b>
Conveyor chain	2898	1	<b>3 842 546 073</b>
Basic chain link 160-320		10	<b>3 842 546 028</b>
Chain plate 240		10	<b>3 842 546 094</b>
Chain pin		100	<b>3 842 547 727</b>
Swivel pin		100	<b>3 842 547 216</b>

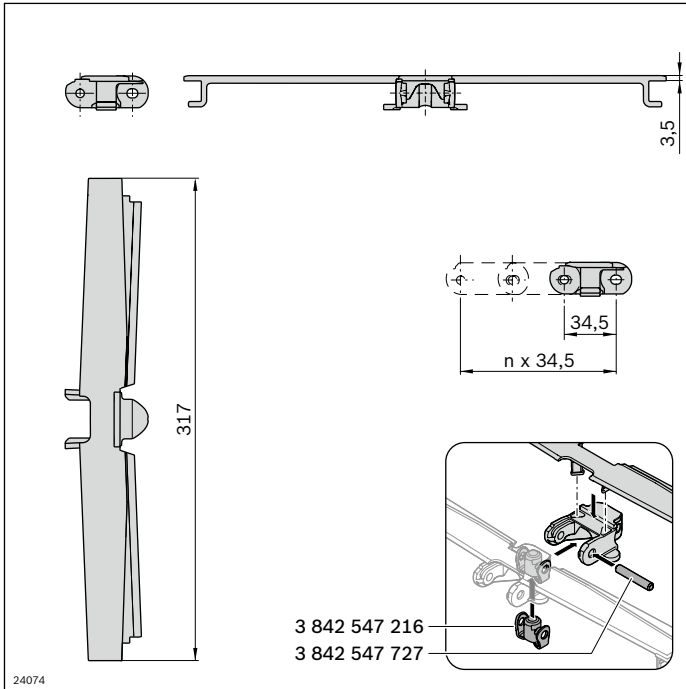

Flat conveyor chain VFplus 320	L (mm)		No.
Conveyor chain	2898	1	<b>3 842 546 074</b>
Basic chain link 160-320		10	<b>3 842 546 028</b>
Chain plate 320		10	<b>3 842 546 095</b>
Chain pin		100	<b>3 842 547 727</b>
Swivel pin		100	<b>3 842 547 216</b>

2

**Information on the attachment of superstructures**

**VFplus 65-120**

**Note:** For superstructures, use the universal chain link.

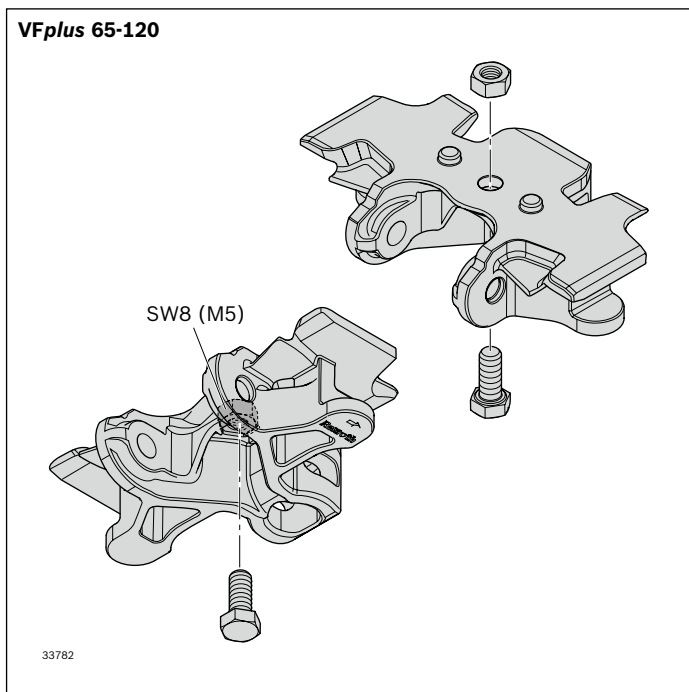

**VFplus 160-320**

**Note:** Risk of collision! Only use the mounting points provided.

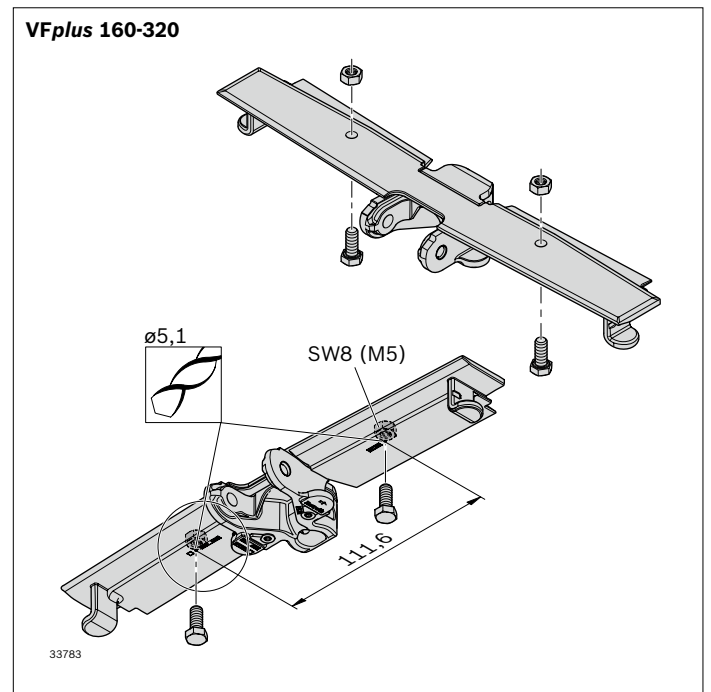



## Static friction chain

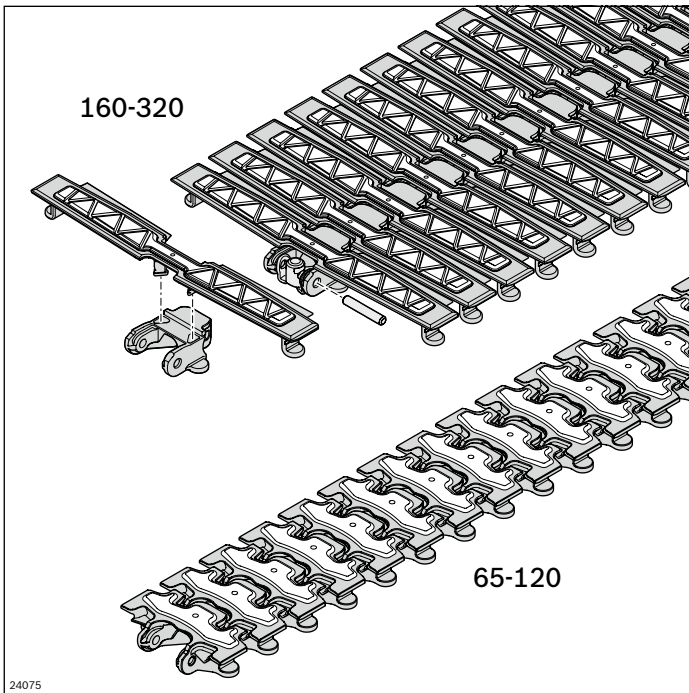

The static friction chain enables the transport of products on ascending or descending sections. The number of chain links with static friction lining can be specified by the user depending on the product size, weight and the inclination.

- Transport possible on ascending or descending sections up to approx. 30°. Maximum gradient depends on the product surface, section length, and speed (test required)
- Accumulation operation not permitted
- Maximum chain tensile force: 1250 N
- From size 160: Chain plate easy to replace
- Only suitable for dry operation
- $AZ \geq 2$ : Static friction chain supplemented with flat chain links ( $AZ =$  spacing distance)  $AZ = 1$ : all links with static friction lining
- The grip is maintained through regular cleaning
- The chain coating is not suited to transporting sharp-edged objects

- ▶ Extremely quiet chain running thanks to the patented chain design
- ▶ Materials meet the requirements of EU 10/2011 and FDA CFR 21

- ▶ Large-area static friction lining for secure product transport

Required accessories for individual chain links:

Chain pin and jointed bolts, see page 23

For basic chain links 160-320, a chain plate is also required, see p. 20

Scope of delivery:

Chain: Complete, incl. chain pin and jointed bolts

Condition on delivery:

Chain: Fully assembled

Material:

- Chain link: POM
- Static friction coating: TPE Shore 70A
- Chain pin: Stainless steel, 1.4301
- Jointed bolts: PA66

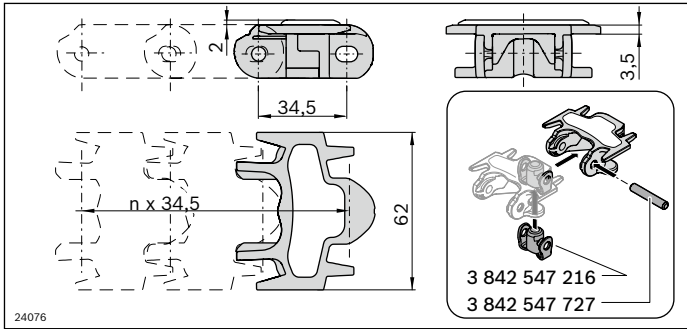

<b>Static friction chain VFplus 65</b>			
	L (mm)		No.
Conveyor chain; AZ = 1	4968	1	<b>3 842 546 077</b>
Conveyor chain; AZ = 2 ... 84	2898	1	<b>3 842 998 706/AZ</b>
Chain link	10		<b>3 842 546 006</b>
Chain pin	100		<b>3 842 547 727</b>
Swivel pin	100		<b>3 842 547 216</b>

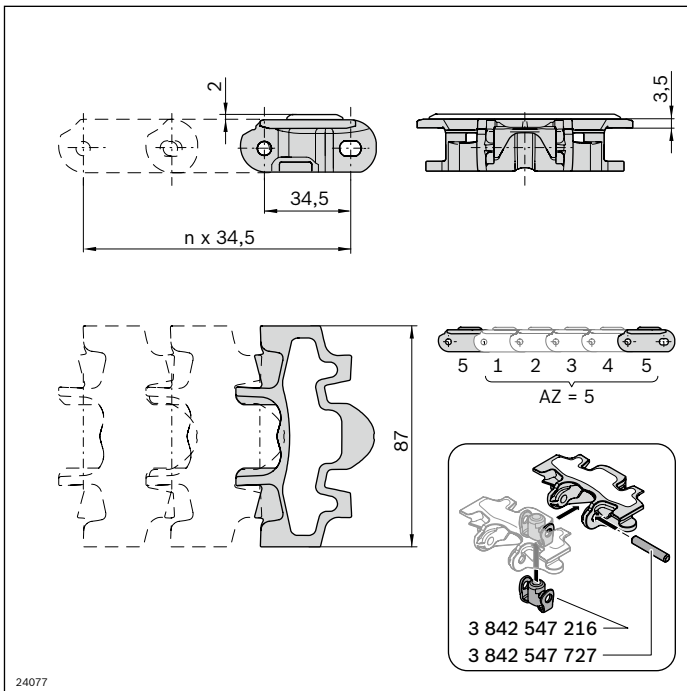

<b>Static friction chain VFplus 90</b>			
	L (mm)		No.
Conveyor chain; AZ = 1	4968	1	<b>3 842 546 078</b>
Conveyor chain; AZ = 2 ... 84	2898	1	<b>3 842 998 707/AZ</b>
Chain link	10		<b>3 842 546 007</b>
Chain pin	100		<b>3 842 547 727</b>
Swivel pin	100		<b>3 842 547 216</b>

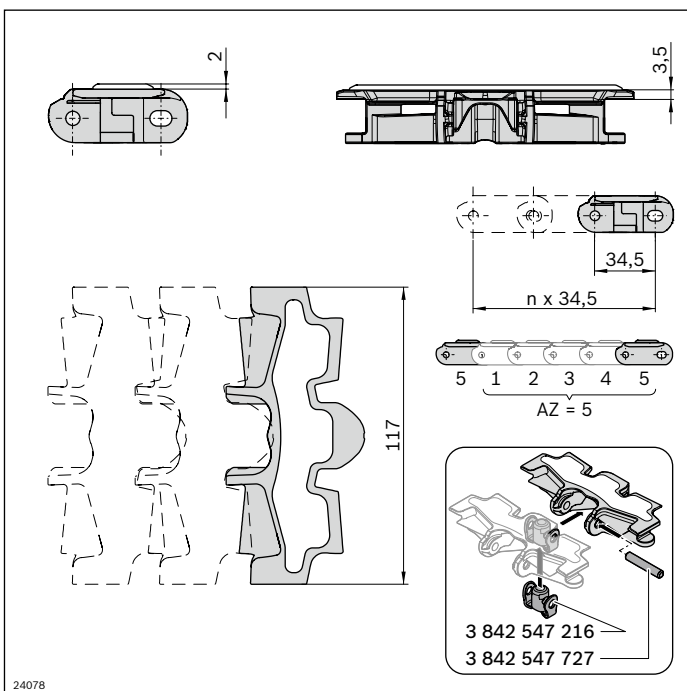

<b>Static friction chain VFplus 120</b>			
	L (mm)		No.
Conveyor chain; AZ = 1	4968	1	<b>3 842 546 079</b>
Conveyor chain; AZ = 2 ... 84	2898	1	<b>3 842 998 708/AZ</b>
Chain link	10		<b>3 842 546 008</b>
Chain pin	100		<b>3 842 547 727</b>
Swivel pin	100		<b>3 842 547 216</b>

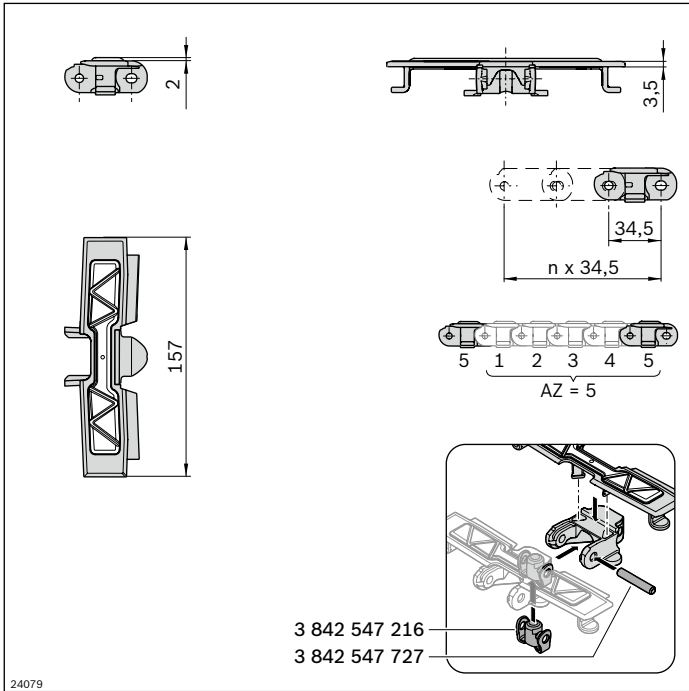

Static friction chain VFplus 160	L (mm)		No.
Conveyor chain; AZ = 1	2898	1	<b>3 842 546 080</b>
Conveyor chain; AZ = 2 ... 84	2898	1	<b>3 842 998 709/AZ</b>
Basic chain link 160-320		10	<b>3 842 546 028</b>
Chain plate 160		10	<b>3 842 546 096</b>
Chain pin		100	<b>3 842 547 727</b>
Swivel pin		100	<b>3 842 547 216</b>

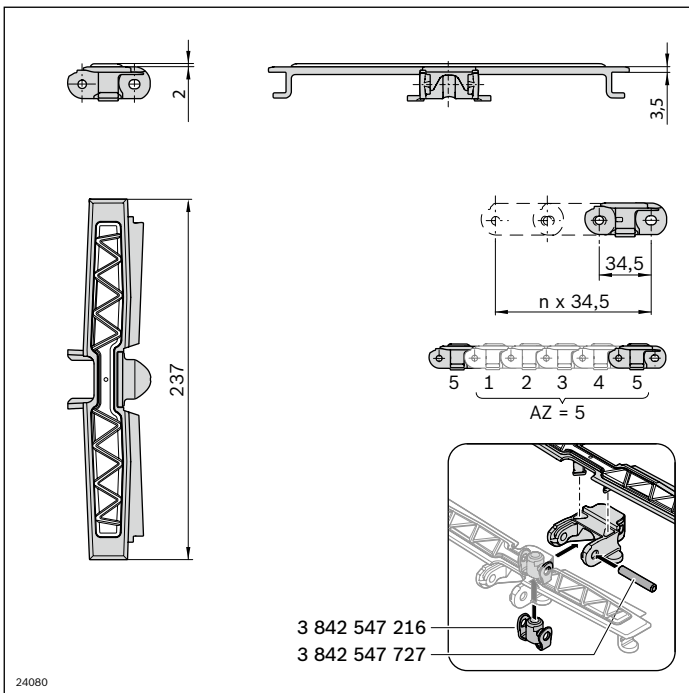

Static friction chain VFplus 240	L (mm)		No.
Conveyor chain; AZ = 1	2898	1	<b>3 842 546 081</b>
Conveyor chain; AZ = 2 ... 84	2898	1	<b>3 842 998 710/AZ</b>
Basic chain link 160-320		10	<b>3 842 546 028</b>
Chain plate 240		10	<b>3 842 546 097</b>
Chain pin		100	<b>3 842 547 727</b>
Swivel pin		100	<b>3 842 547 216</b>



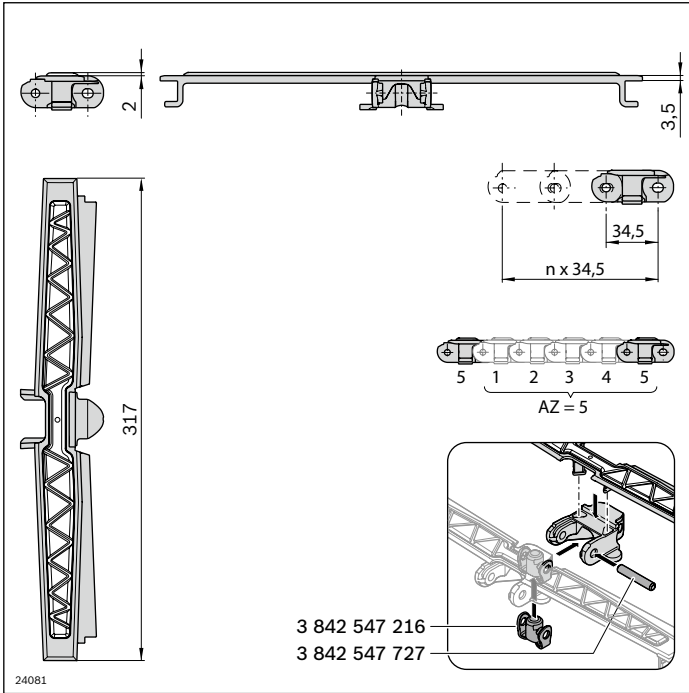

Static friction chain VFplus 320	L (mm)	No.
Conveyor chain; AZ = 1	2898	1 <b>3 842 546 082</b>
Conveyor chain; AZ = 2 ... 84	2898	1 <b>3 842 998 711/AZ</b>
Basic chain link 160-320	10	<b>3 842 546 028</b>
Chain plate 320	10	<b>3 842 546 098</b>
Chain pin	100	<b>3 842 547 727</b>
Swivel pin	100	<b>3 842 547 216</b>

## Accumulation roller chain D11, Roller cleat chain D11

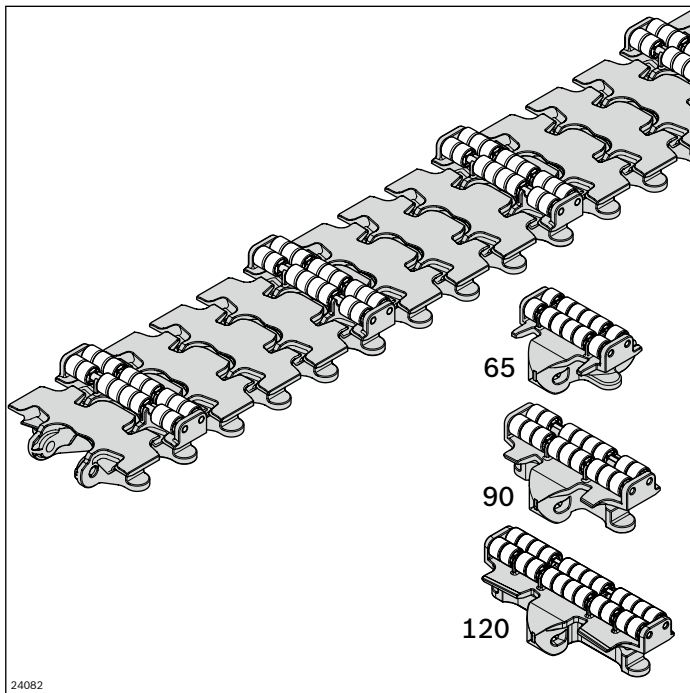

The accumulation roller chain D11 (AZ = 1) enables the surface-protecting and exclusively horizontal transport of sensitive products, even in accumulation operation. Its use as a roller cleat chain (AZ ≥ 2) enables the vertical transport of small products. See also “Layout instructions for roller cleat chains”, on page 34

- The maximum gradient when using cleats depends on the product geometry (test required)
- Accumulation operation permitted when used as an accumulation roller chain (AZ = 1)  
Accumulation operation not permitted when used as a roller cleat chain (AZ ≥ 2)
- Maximum chain tensile force: 1250 N
- AZ ≥ 2: Roller cleat chain supplemented with flat chain links (AZ = spacing distance) AZ = 1: continuous accumulation roller chain
- Product length for use with the accumulation roller chain: ≥ 70 mm

- ▶ Extremely quiet chain running thanks to the patented chain design

- ▶ Materials meet the requirements of EU 10/2011 and FDA CFR 21

Required accessories for individual chain links:  
Chain pin and jointed bolts, see page 28

Scope of delivery:  
Chain: Complete, incl. chain pin and jointed bolts

Condition on delivery:  
Chain: Fully assembled

- Material:
- Chain link: POM
  - Roller: POM
  - Chain pin: Stainless steel, 1.4301
  - Jointed bolts: PA66

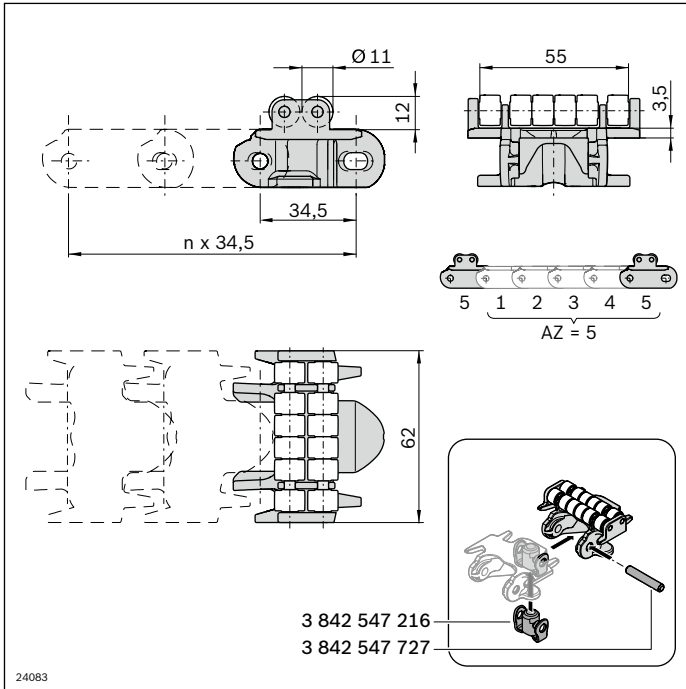

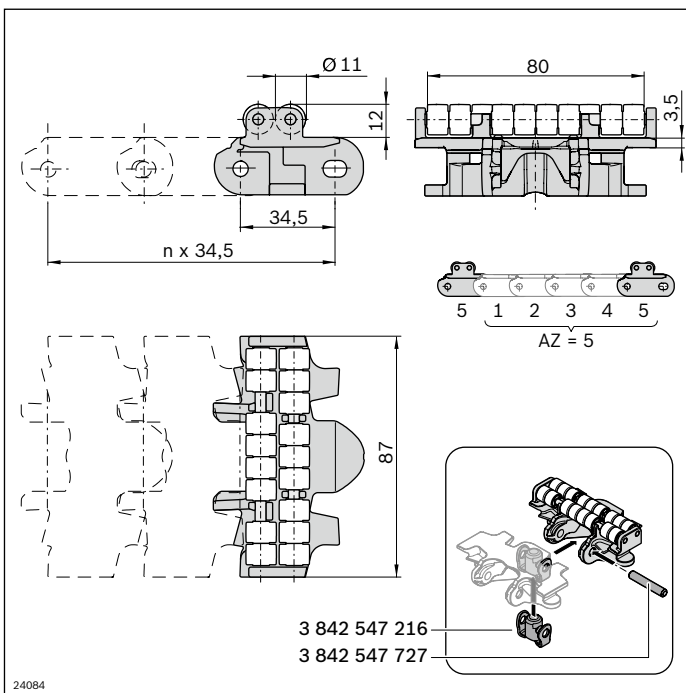

Accumulation roller chain D11 VFplus 65	L (mm)	No.
Conveyor chain; AZ = 1	2898	1 <b>3 842 546 083</b>
Conveyor chain; AZ = 2 ... 84	2898	1 <b>3 842 998 717/AZ</b>
Chain link	10	<b>3 842 546 017</b>
Chain pin	100	<b>3 842 547 727</b>
Swivel pin	100	<b>3 842 547 216</b>



Accumulation roller chain D11 VFplus 90	L (mm)	No.
Conveyor chain; AZ = 1	2898	1 <b>3 842 546 084</b>
Conveyor chain; AZ = 2 ... 84	2898	1 <b>3 842 998 718/AZ</b>
Chain link	10	<b>3 842 546 018</b>
Chain pin	100	<b>3 842 547 727</b>
Swivel pin	100	<b>3 842 547 216</b>

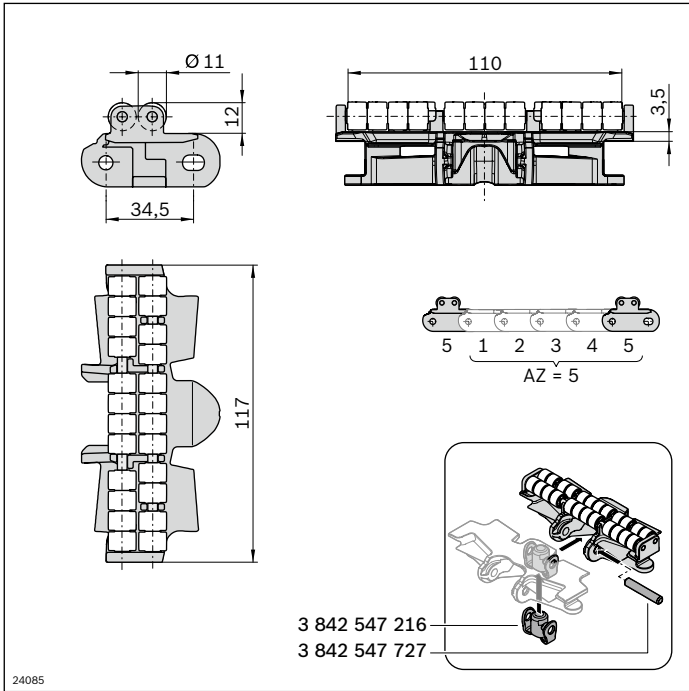



<b>Accumulation roller chain D11 VFplus 120</b>	<b>L (mm)</b>		<b>No.</b>
Conveyor chain; AZ = 1	2898	1	<b>3 842 546 085</b>
Conveyor chain; AZ = 2 ... 84	2898	1	<b>3 842 998 719/AZ</b>
Chain link		10	<b>3 842 546 019</b>
Chain pin		100	<b>3 842 547 727</b>
Swivel pin		100	<b>3 842 547 216</b>

24085



## Roller cleat chain D20

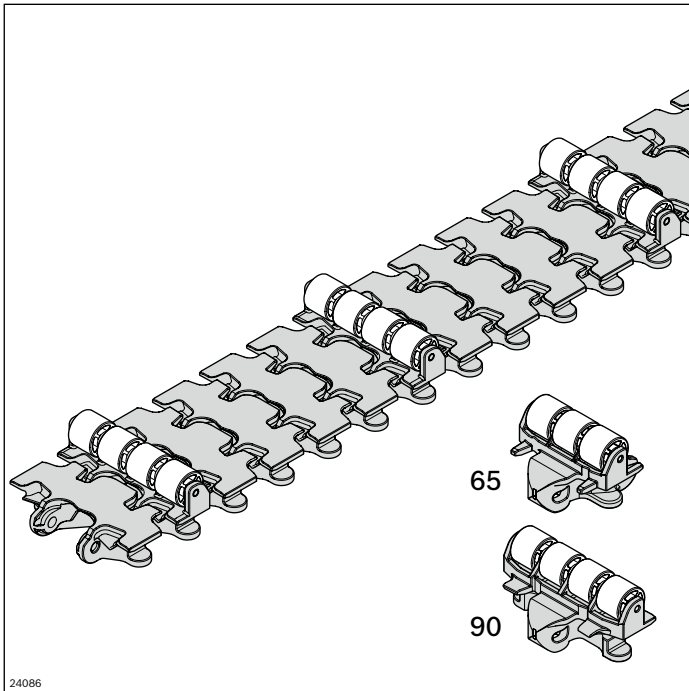

The roller cleat chain D20 enables the transport of products on ascending or descending sections. See also “Layout instructions for roller cleat chains”, on page 34

- The maximum gradient depends on the product geometry (test required)
- Accumulation operation not permitted
- Maximum chain tensile force: 1250 N
- $AZ \geq 2$ : Roller cleat chain supplemented with flat chain links (AZ = spacing distance)

- ▶ Extremely quiet chain running thanks to the patented chain design
- ▶ Materials meet the requirements of EU 10/2011 and FDA CFR 21

- ▶ For infeeding without any effort for cycle time adjustment

Required accessories for individual chain links:

Chain pin and jointed bolts, see page 31

Scope of delivery:

Chain: Complete, incl. chain pin and jointed bolts

Condition on delivery:

Chain: Fully assembled

Material:

- Chain link: POM
- Roller: POM
- Chain pin: Stainless steel, 1.4301
- Jointed bolts: PA66

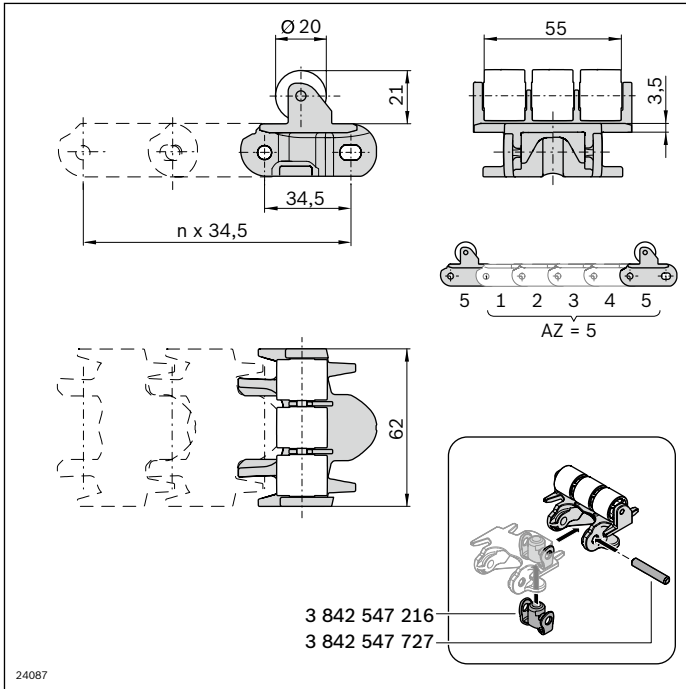

<b>Roller cleat chain D20 VFplus 65</b>	<b>L (mm)</b>		<b>No.</b>
Conveyor chain; AZ = 2 ... 84	2898	1	<b>3 842 998 720/AZ</b>
Chain link	10		<b>3 842 546 020</b>
Chain pin	100		<b>3 842 547 727</b>
Swivel pin	100		<b>3 842 547 216</b>

2

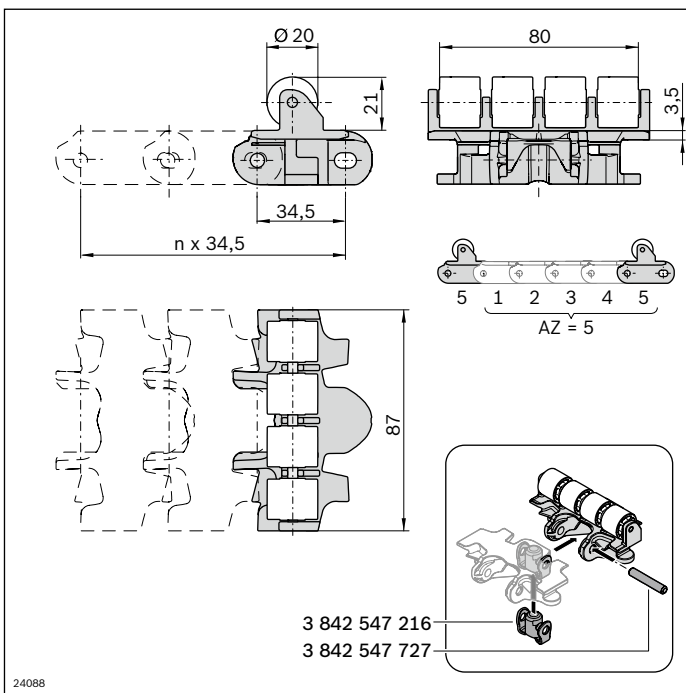

<b>Roller cleat chain D20 VFplus 90</b>	<b>L (mm)</b>		<b>No.</b>
Conveyor chain; AZ = 2 ... 84	2898	1	<b>3 842 998 721/AZ</b>
Chain link	10		<b>3 842 546 021</b>
Chain pin	100		<b>3 842 547 727</b>
Swivel pin	100		<b>3 842 547 216</b>



## Roller cleat D35

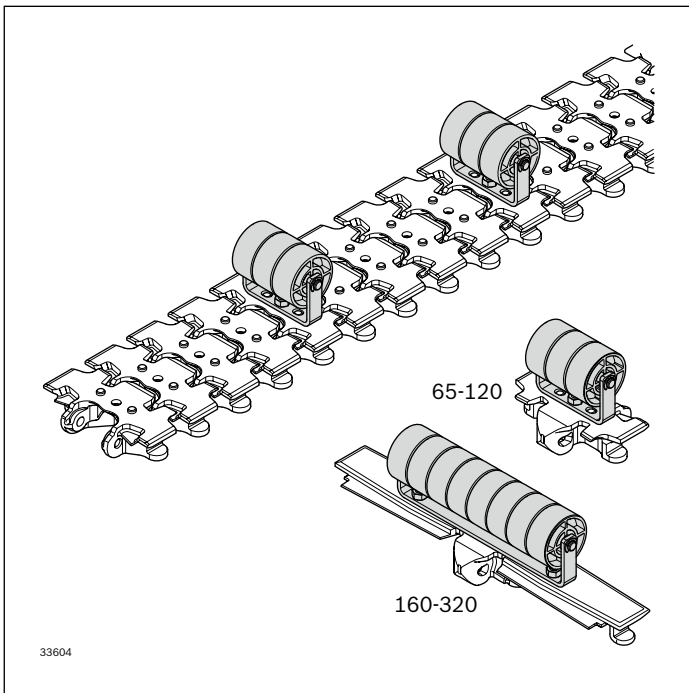

The roller cleat D35 enables the transport of large-volume products on ascending or descending sections. See also “Layout instructions for roller cleat chains”, page 34.

- The maximum gradient depends on the product geometry (test required)
- Accumulation operation not permitted
- Maximum chain tensile force: 1250 N
- Static force: 100 N
- Dynamic force: 10 N
- 2 types:
  - For sizes 65 -120
  - For sizes 160 -320

**Note:**

The chain plate with roller cleat must be screwed to the basic chain link.

- ▶ A D35 roller cleat chain is created easily by mounting the roller cleat on the universal chain link (65-120). Drilling the basic chain links (160-320) allows for the simple attachment of the roller cleat. A mold cavity for accommodating a flat M5 hexagon nut/screw is present, see page 21, 40
- ▶ For infeeding without any effort for cycle time adjustment

- ▶ Extremely quiet chain running thanks to the patented chain design
- ▶ Materials meet the requirements of EU 10/2011 and FDA CFR 21

**Required accessories:**

Universal chain links 65-120, see page 18 and page 38,  
basic chain links 160-320, see page 20

**Scope of delivery:**

Roll bar mounted, incl. fastening material

**Material:**

- Roller: POM, white
- Roll bar, axle: Stainless steel, 1.4301

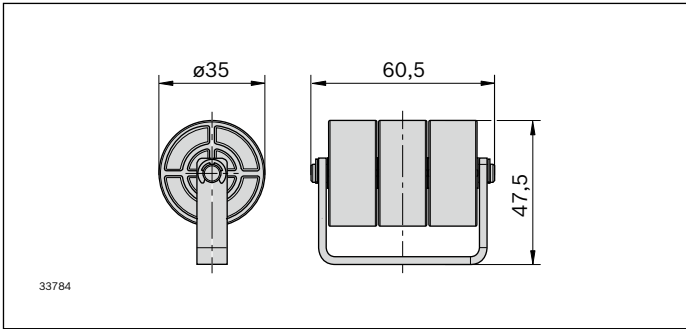

Roller cleat D35	No.
65-120	1 3 842 546 107

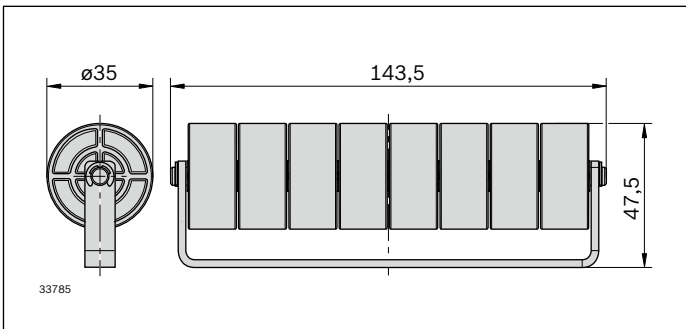

Roller cleat D35	No.
160-320	1 3 842 553 028

2

**Information on the attachment of superstructures**

**VFplus 65-120**

**Note:** For superstructures, use the universal chain link.

**VFplus 160-320**

**Note:** Risk of collision! Only use the mounting points provided.

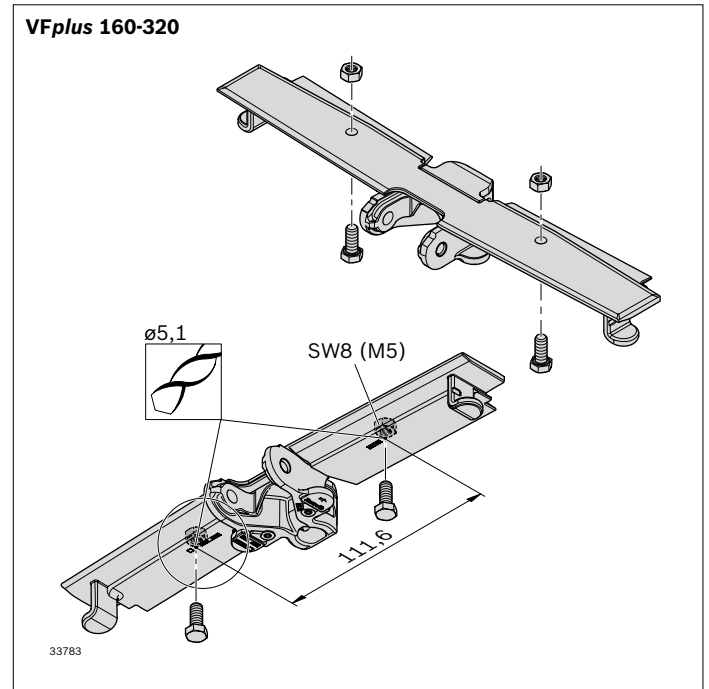
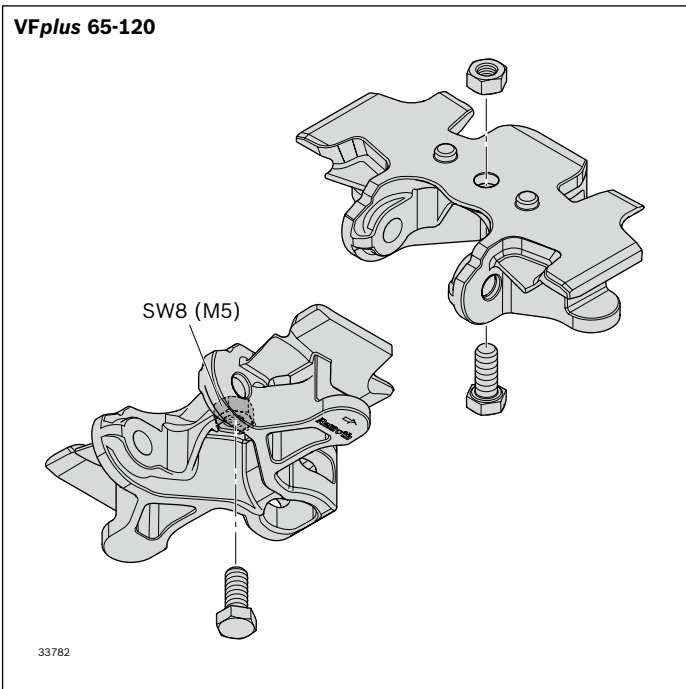

# Layout instructions for roller cleat chains

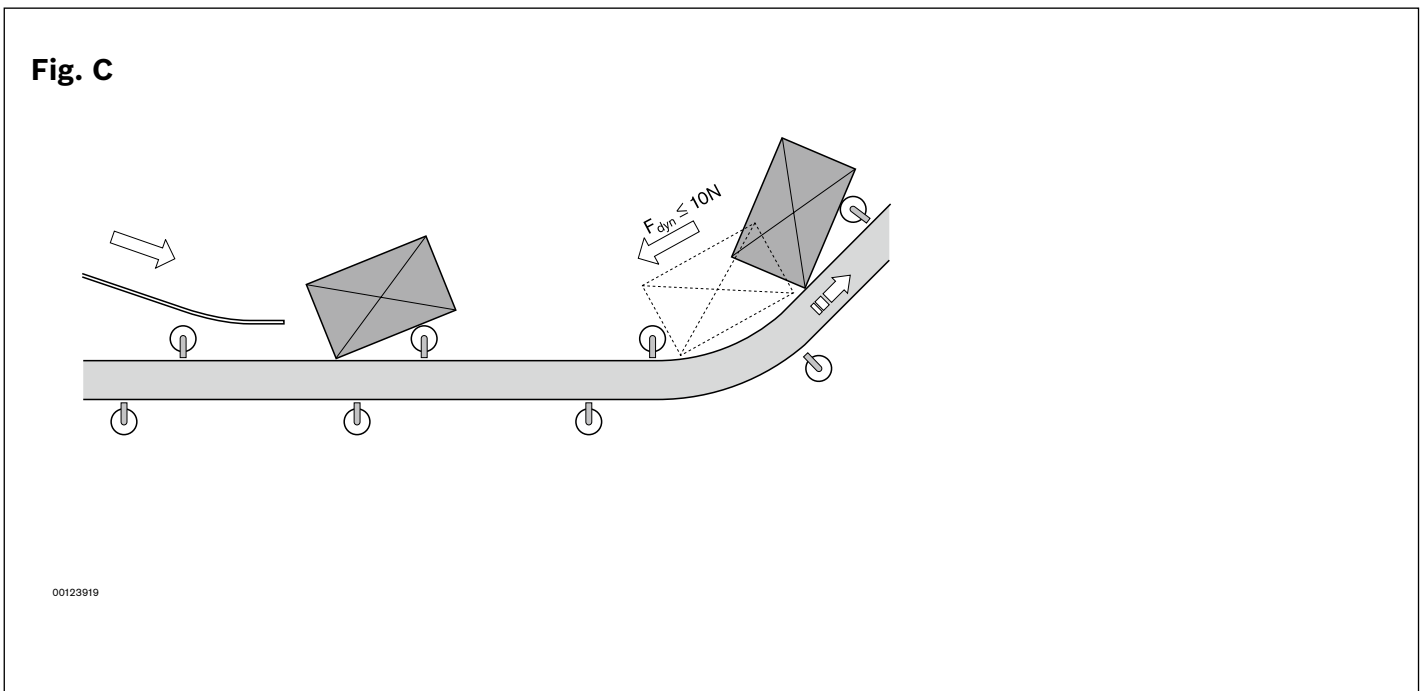
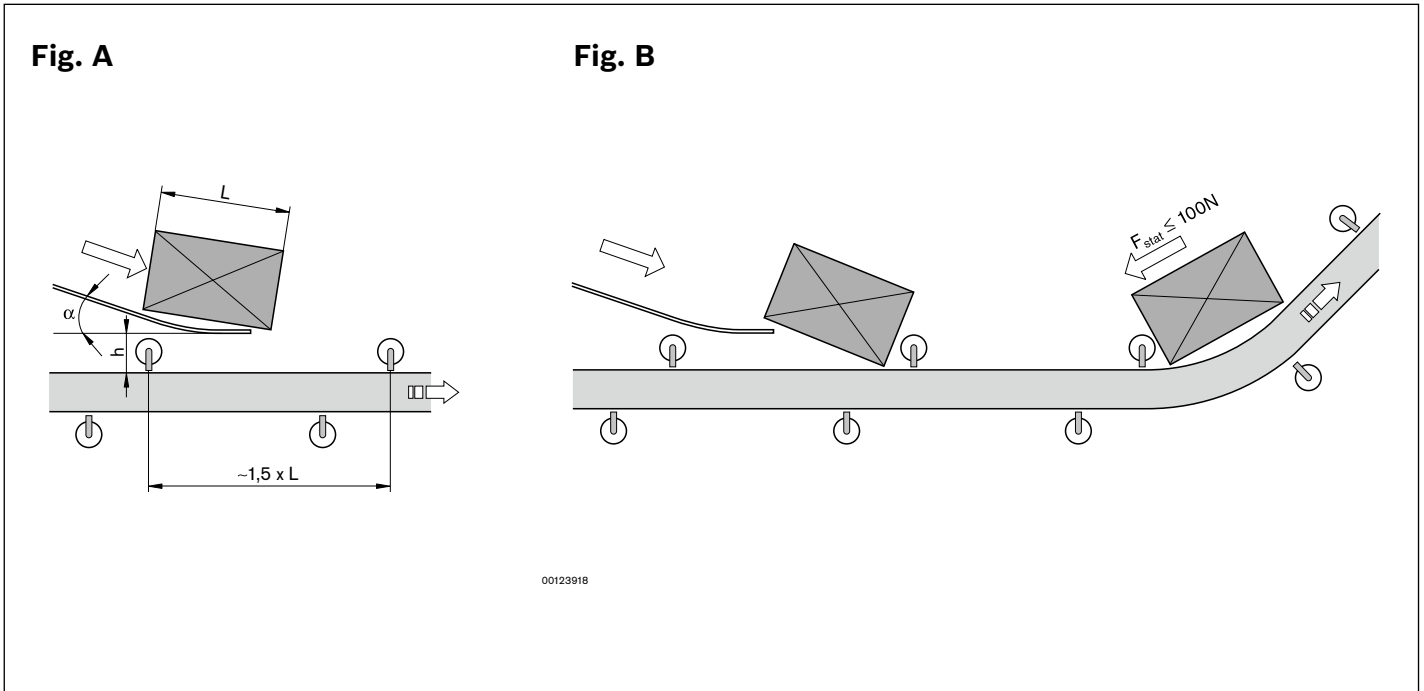

**Roller cleat chain**

During uphill transport of packaged, bulky products (e.g. boxes), the products can slide between the roller cleats via a chute to be diagonally “inserted” into the transport direction from above. The product rolls into the next free pocket, which ensures continuous material flow without any expensive cycle time adjustment.

The roller diameter is dependent on the size of the transported goods.

When planning, observe the following (see Fig. A):

- Keep height of fall “h” and angle “ $\alpha$ ” as small as possible.
- The speed of the inserted product should be about the same as that of the conveyor system. Reduce higher speeds by braking (e.g. brushes) before inserting into the roller cleat chain.

Always prevent the product from transmitting its kinetic energy to the roller cleats

- Feed in the direction of transport of the roller cleat chain.
- Distance between roller cleats approx. 1.5x product length (ensures smooth movement through vertical curves).
- Removal speed:  
2x product length x 1.5x product quantity/min.

This ensures that each product has two pockets available to slide into, either forwards or backwards (see Fig. B, C).

- Max. dynamic force of product when sliding backwards against the roller cleat: 10 N
- Max. static force due to adjacent product: 100 N

At higher forces, decrease the angle of inclination or reduce the speed of impact by installing individual static friction chain links between the roller cleats.



## Cleated chain

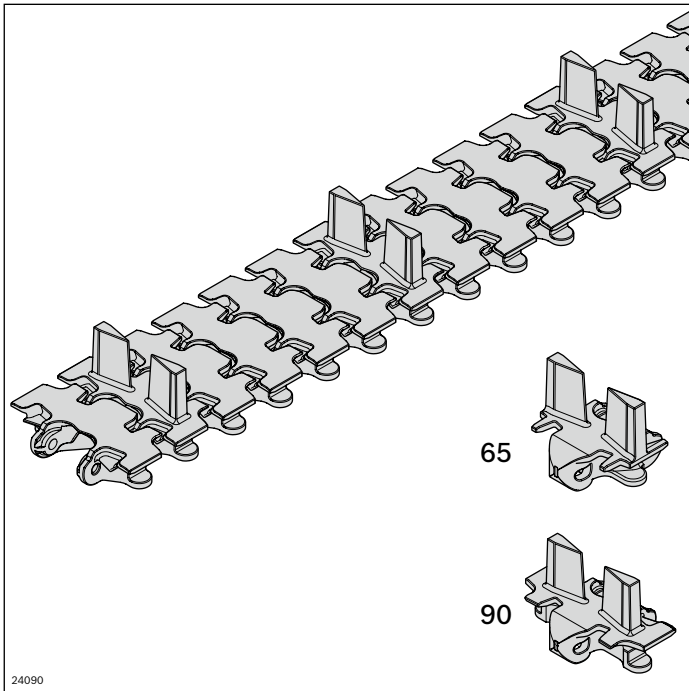

The cleated chain enables the transport of products on ascending or descending sections.

- The maximum gradient depends on the product geometry (test required)
- Accumulation operation not permitted
- Maximum chain tensile force: 1250 N
- $AZ \geq 2$ : Cleated chain supplemented with flat chain links (AZ = spacing distance)

- ▶ Extremely quiet chain running thanks to the patented chain design
- ▶ Materials meet the requirements of EU 10/2011 and FDA CFR 21

- ▶ The centrally divided cleat allows for the simple transfer of conveyed material at the section ends: A transfer area only needs to be recessed in the area of the cleat and can otherwise be used near to the submerging chain

Required accessories for individual chain links:  
Chain pin and jointed bolts, see page 37

Scope of delivery:  
Chain: Complete, incl. chain pin and jointed bolts

Condition on delivery:  
Chain: Fully assembled

- Material:
- Chain link: POM
  - Chain pin: Stainless steel, 1.4301
  - Jointed bolts: PA66

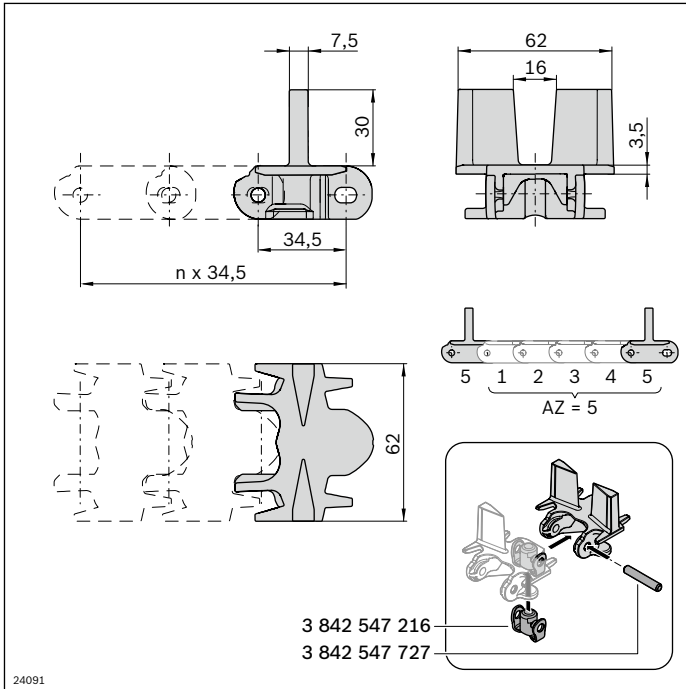

<b>Cleated chain VFplus 65</b>	<b>L (mm)</b>		<b>No.</b>
Conveyor chain; AZ = 2 ... 84	2898	1	<b>3 842 998 715/AZ</b>
Chain link		10	<b>3 842 546 015</b>
Chain pin		100	<b>3 842 547 727</b>
Swivel pin		100	<b>3 842 547 216</b>

2

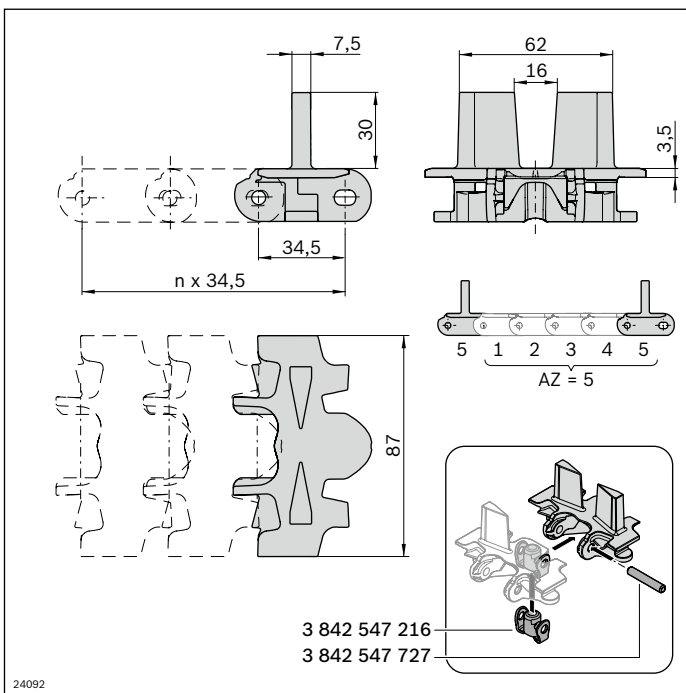

<b>Cleated chain VFplus 90</b>	<b>L (mm)</b>		<b>No.</b>
Conveyor chain; AZ = 2 ... 84	2898	1	<b>3 842 998 716/AZ</b>
Chain link		10	<b>3 842 546 016</b>
Chain pin		100	<b>3 842 547 727</b>
Swivel pin		100	<b>3 842 547 216</b>

## Universal chain

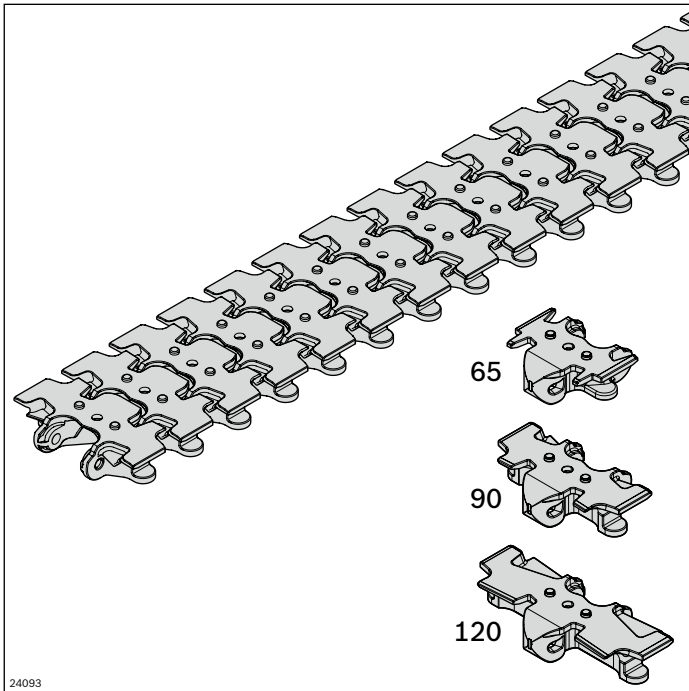

- ▶ Extremely quiet chain running thanks to the patented chain design
- ▶ Materials meet the requirements of EU 10/2011 and FDA CFR 21

Required accessories for individual chain links:  
Chain pin and jointed bolts, see page 39

Scope of delivery:  
Chain: Complete, incl. chain pin and jointed bolts

- Material:
- Chain link: POM
  - Chain pin: Stainless steel, 1.4301
  - Jointed bolts: PA66

The universal chain serves as mounting base for the assembly of customer-specific cleats or superstructures.

- The maximum gradient depends on the customer-specific cleats (test required)
- Accumulation operation not permitted
- Maximum chain tensile force: 1250 N
- $AZ \geq 2$ : Universal chain supplemented with flat chain links  
AZ = 1: complete conveyor chain with universal chain links (AZ = spacing distance)

- ▶ A mold cavity for mounting a flat M5 hexagon nut on the underside of the chain plate as well as the integrated anti-torsion element (pin) facilitate the simple, centered attachment of superstructures, see page 40

- Optional accessories:
- Static friction chain link, see p. 22
  - Accumulation roller chain link D11, see p. 26
  - Roller cleat chain link D20, see p. 30
  - Cleated chain link, see p. 36

Condition on delivery:  
Chain: Fully assembled

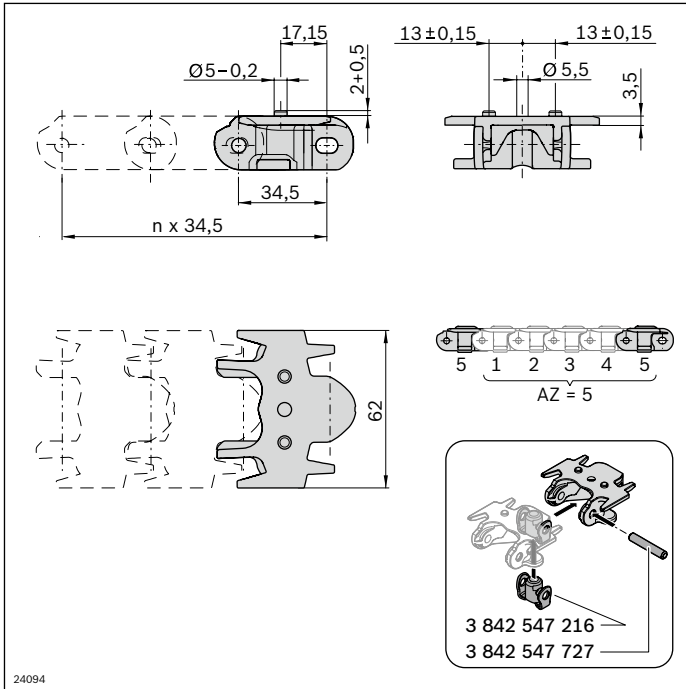

Universal chain VFplus 65	L (mm)	No.
Conveyor chain; AZ = 1 ... 84	2898	1 <b>3 842 998 712/AZ</b>
Chain link	10	<b>3 842 546 012</b>
Chain pin	100	<b>3 842 547 727</b>
Swivel pin	100	<b>3 842 547 216</b>

2

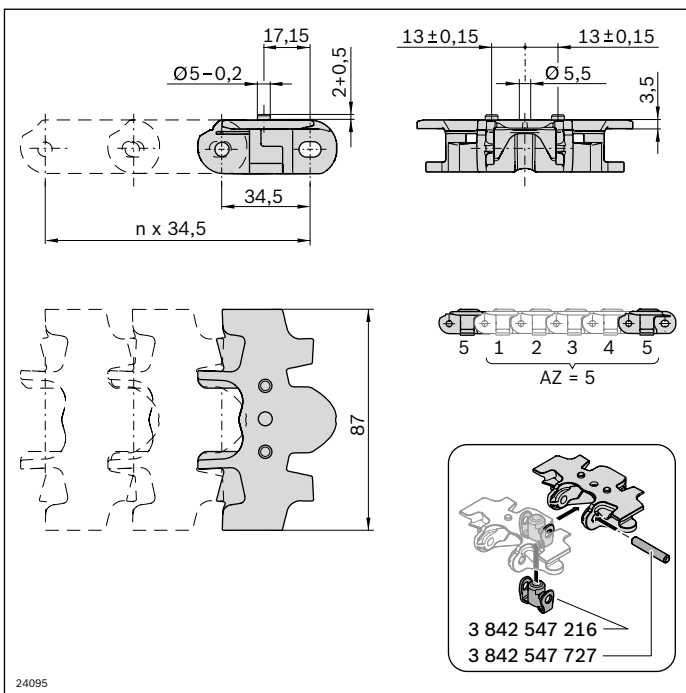

Universal chain VFplus 90	L (mm)	No.
Conveyor chain; AZ = 1 ... 84	2898	1 <b>3 842 998 713/AZ</b>
Chain link	10	<b>3 842 546 013</b>
Chain pin	100	<b>3 842 547 727</b>
Swivel pin	100	<b>3 842 547 216</b>



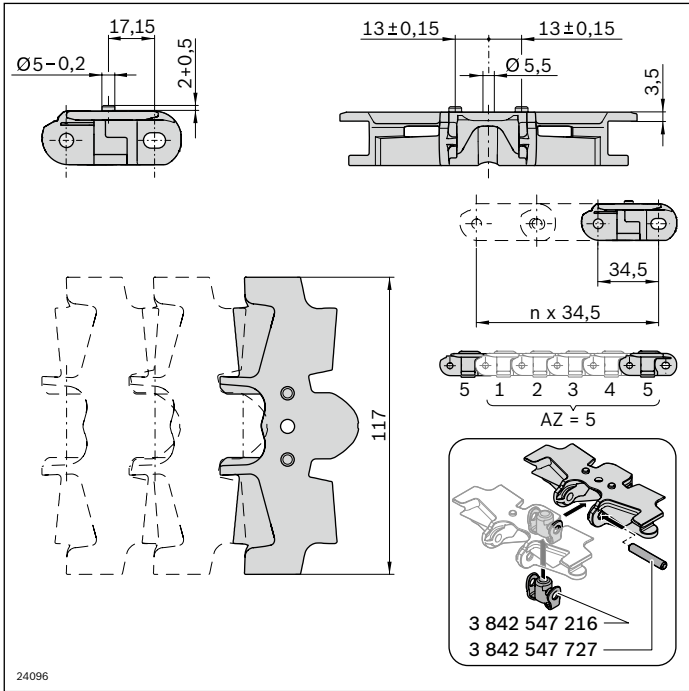

Universal chain VFplus 120	L (mm)		No.
Conveyor chain; AZ = 1 ... 84	2898	1	<b>3 842 998 714/AZ</b>
Chain link		10	<b>3 842 546 014</b>
Chain pin		100	<b>3 842 547 727</b>
Swivel pin		100	<b>3 842 547 216</b>

### Information on the attachment of superstructures

#### VFplus 65-120

**Note:** For superstructures, use the universal chain link.

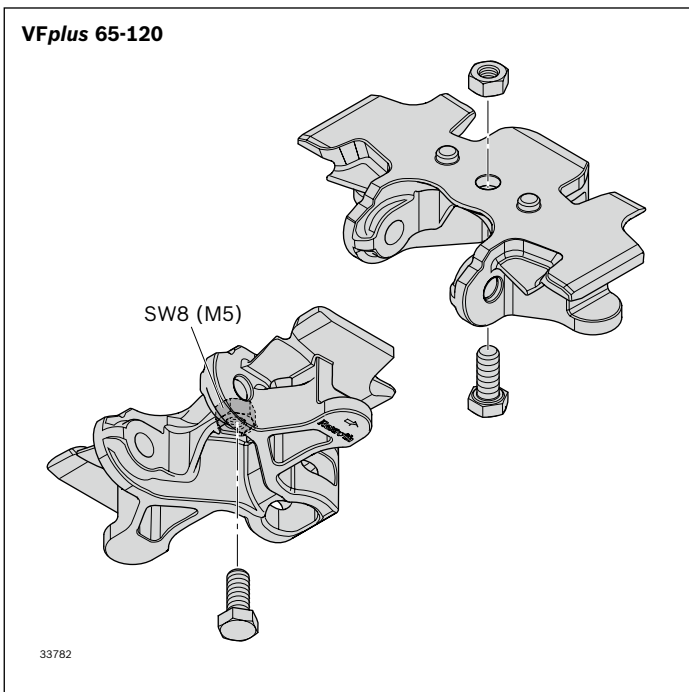



## Steel-coated chain

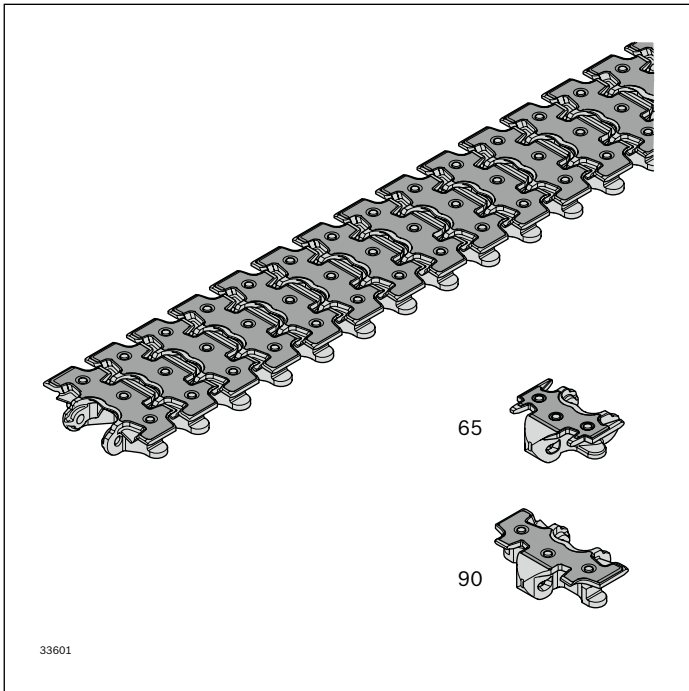

The steel-coated chain is used for sharp-edged parts and products with a rough surface.

- Transport on ascending or descending sections up to 7° possible, depending on the product (test required)
- Accumulation operation permitted, depending on the product
- Maximum chain tensile force: 1250 N
- Size: 65, 90
- Combination with chain links of different chain types is not permitted

**Note:** We recommend using steel slide rails (see page 58), as abrasive particles cause increased wear.

**Note:**

Not suitable for standard VarioFlow plus WT system.

- ▶ The stainless version is also suitable for use in wet ambient conditions
- ▶ This chain version offers quieter running and less maintenance (no lubrication) compared with completely steel chains

- ▶ Extremely quiet chain running thanks to the patented chain design
- ▶ Materials meet the requirements of EU 10/2011 and FDA CFR 21

Scope of delivery:

Chain: Complete, incl. chain pin and jointed bolts

Condition on delivery:

Chain: Fully assembled

Material:

- Chain link: POM, white
- Steel coating: Stainless steel 1.4301, HV ≥ 480
- Chain pin: Stainless steel, 1.4301
- Jointed bolts: PA66

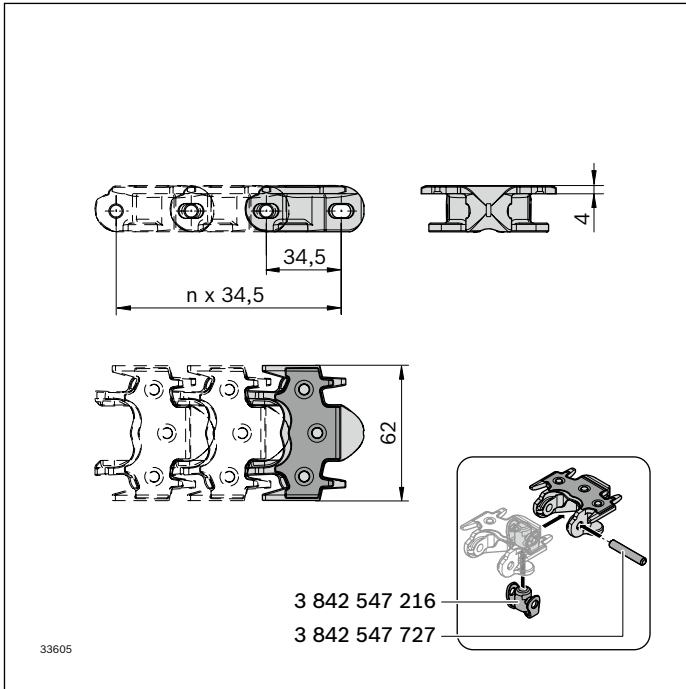

Steel-coated chain <i>VFplus 65</i>	L (mm)	 No.
	4968	1 <b>3 842 546 090</b>

2

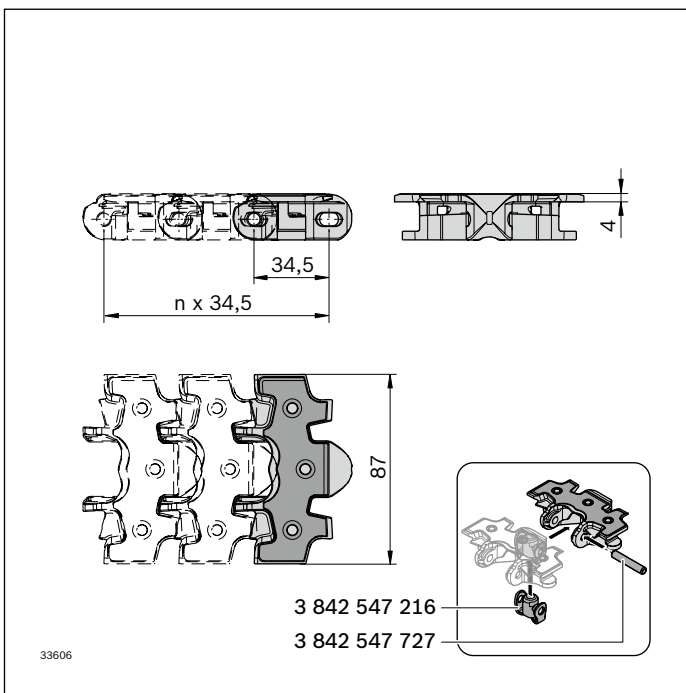

Steel-coated chain <i>VFplus 90</i>	L (mm)	 No.
	4968	1 <b>3 842 546 091</b>



## Flocked chain

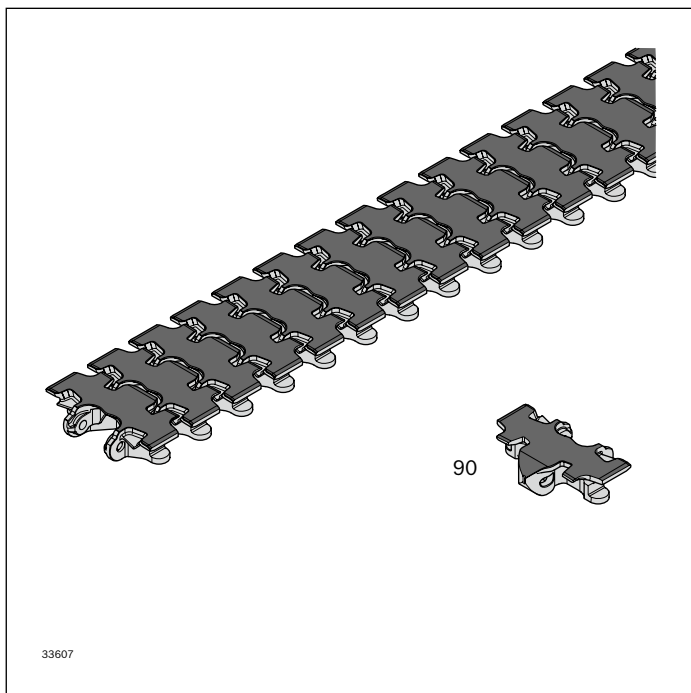

The flocked chain is used on sensitive transport surfaces (e.g. gloss, clear, barcode, raised printing).

- Transport on ascending or descending sections up to 7° possible, depending on the product (test required)
- For products susceptible to jams
- Only dry use
- Maximum permissible tracking force: 5 N/chain link
- Maximum chain tensile force: 1250 N
- Size: 90
- Not suitable for sharp-edged products
- Combination with chain links of different chain types is not permitted

**Note:**

Not suitable for standard VarioFlow *plus* WT system.

- ▶ Soft PA-flocking 3.3 dtex for sensitive product surfaces
- ▶ Extremely quiet chain running thanks to the patented chain design

**Scope of delivery:**

Chain: Complete, incl. chain pin and jointed bolts

**Condition on delivery:**

Chain: Fully assembled

**Material:**

- Chain link: POM, white
- Flocking: PA 3.3 dtex, anthracite
- Chain pin: Stainless steel, 1.4301
- Jointed bolts: PA66

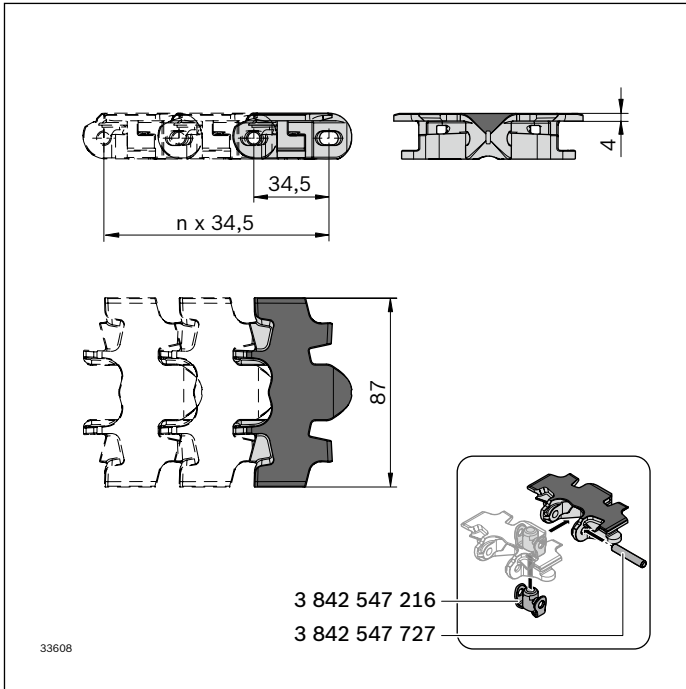

Flocked chain VFplus 90	L (mm)	No.
	4968	1 3 842 553 023

## Clamping chain

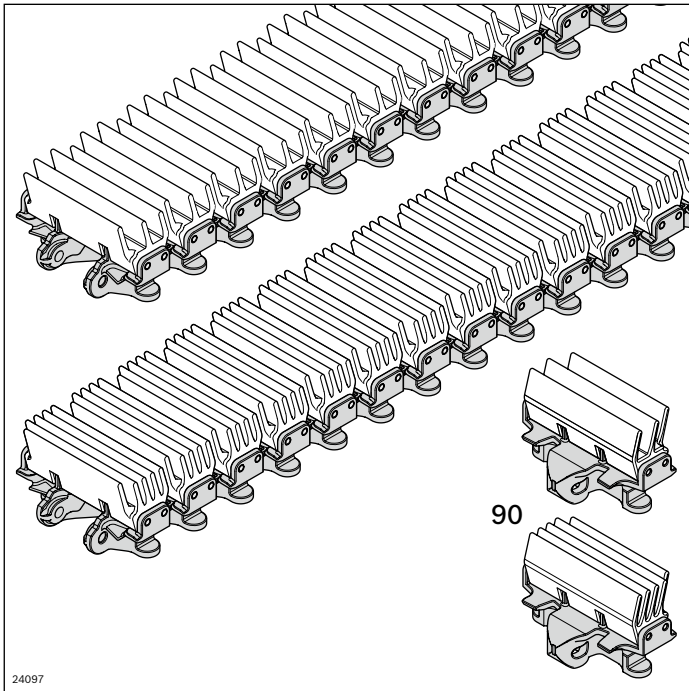

- ▶ Extremely quiet chain running thanks to the patented chain design
- ▶ Materials comply with the requirements of FDA CFR 21

**Scope of delivery:**

Chain: Complete, incl. chain pin and jointed bolts

**Condition on delivery:**

Chain: Fully assembled

The wedge chain clamps products to enable transport across different heights or distances.

Particularly used when the product being transported

- Is difficult to transport vertically due to its shape
- Cannot be transported up steep gradients with other chains due to its center of gravity
- Has sensitive surfaces that would be damaged by lateral or upper guides
- Must not slip during vertical transport
- Should be transported without synchronization

- Transport options with clamping chain depend on the product geometry (test required)
- Accumulation operation not permitted
- Maximum chain tensile force: 1250 N
- Only suitable for dry operation
- Chain available in 2 versions: 5 plates (5L) for products insensitive to pressure 3 plates (3L) for products sensitive to pressure

For information on contact pressure in the wedge conveyor, see page 47

- An assembly module is required for assembling and disassembling the chain
- The lamellae are not suitable for transporting sharp-edged objects

See also “Setting up a wedge conveyor” on page 192.

**Material:**

- Chain link: POM
- Plates: TPE, Shore A 55
- Chain pin: Stainless steel, 1.4301
- Jointed bolts: PA66

**Contact pressure in wedge conveyor**

Compressive deformation value:  
< 40%

“s” depends on the product’s size, weight and surface properties.  
Tests may be necessary.

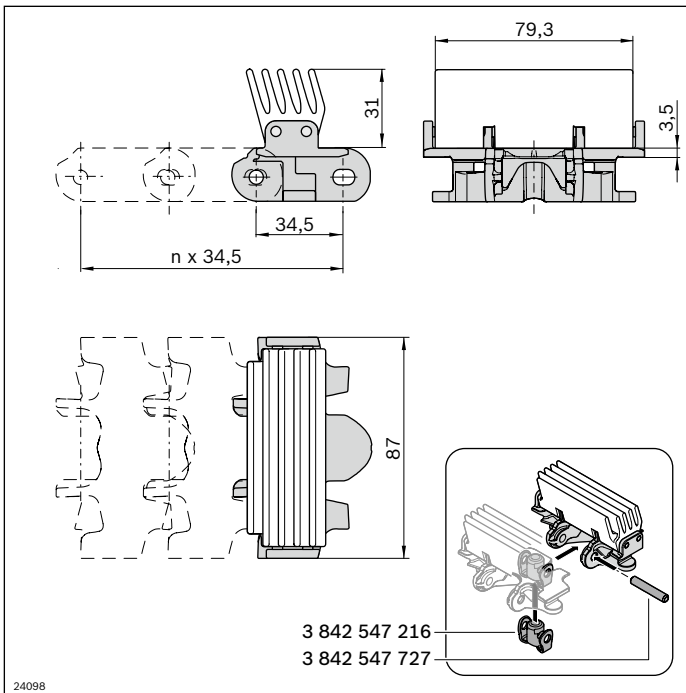
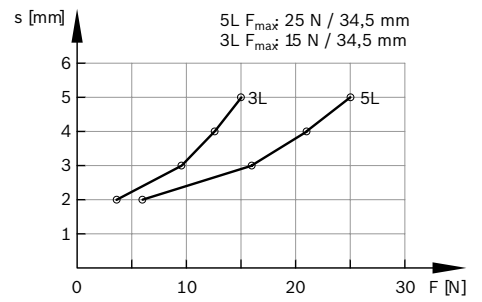
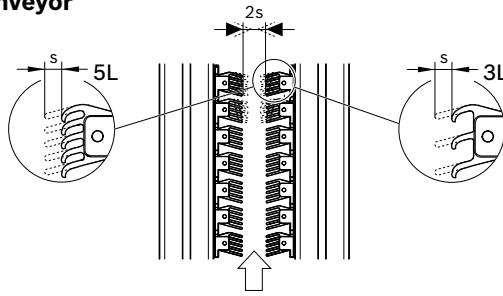

Clamping chain VF90plus 5L	L (mm)	No.
	2898	1 3 842 546 086

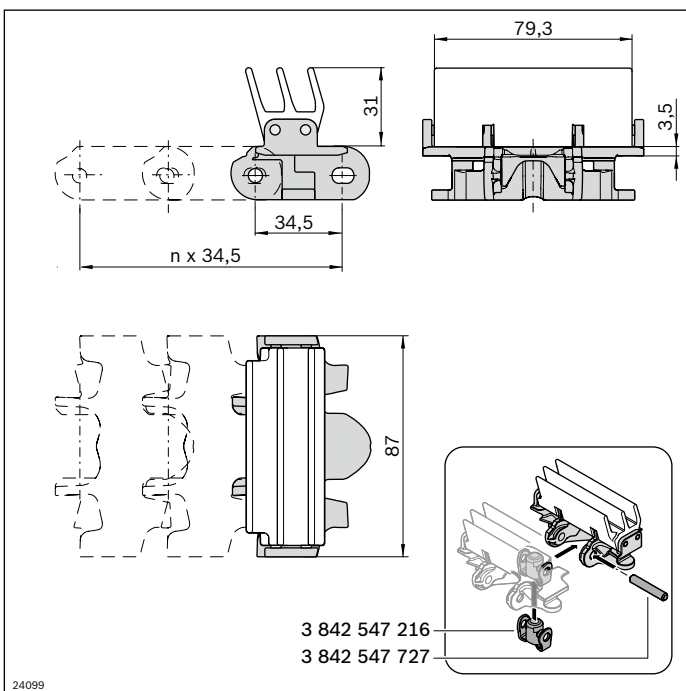

Clamping chain VF90plus 3L	L (mm)	No.
	2898	1 3 842 546 087





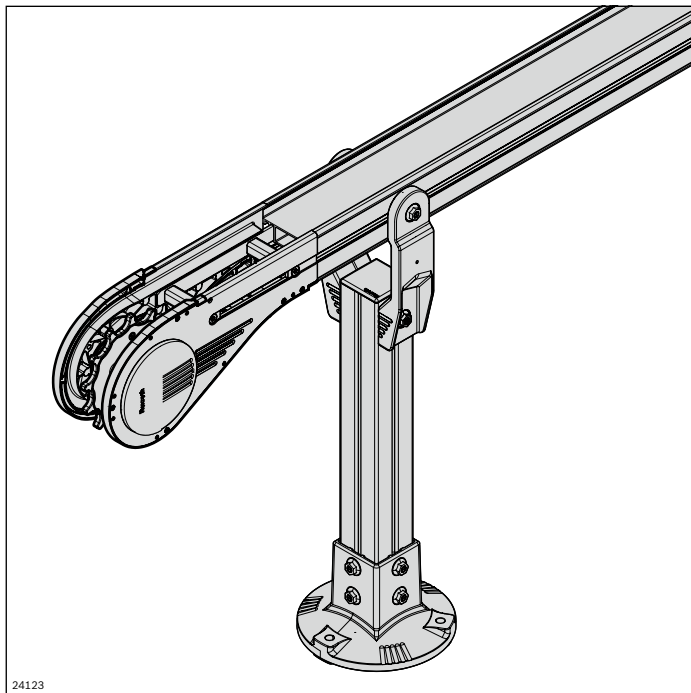

# VarioFlow *plus* Aluminum system (AL)



- ▶ Fixing of slide rails without rivets or the need to machine the track bearing surfaces
- ▶ Minimal slide rail interruptions
- ▶ FDA-compliant, low-friction materials for components subject to constant friction
- ▶ Standardized components that can be used universally
- ▶ Continuous product range in the sizes 65, 90, 120, 160, 240, 320

Economical section routing for a wide range of applications in the automotive and electronics industries, machine interlinking, or in the areas of food & packaging and health & care





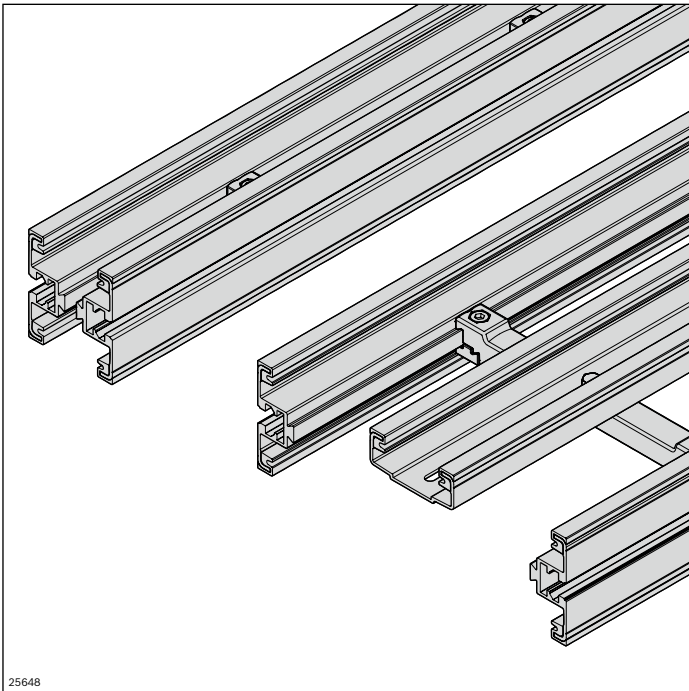

	<b>Sections AL</b>	<b>50</b>
	<b>AL curves</b>	<b>66</b>
	<b>Drive and return unit AL</b>	<b>76</b>
	<b>AL leg sets and fastening elements</b>	<b>108</b>

## Sections AL



- ▶ Fixing of slide rails without rivets or the need to machine the track bearing surfaces
- ▶ Optimized sliding characteristics and FDA-compliant materials for the slide rail
- ▶ One slide rail cross-section for all sizes
- ▶ Connection technology with plug-through screws
- ▶ Few screwed connections
- ▶ Easy to clean thanks to ample draining surfaces
- ▶ One profile cross-section for open construction in all sizes
- ▶ Closed profile in the sizes 65, 90, 120
- ▶ Use of a support profile from size 160

Simple assembly of sections thanks to smart connection technology

	<b>Section profile AL closed</b>	<b>52</b>
	<b>Section profile AL open</b>	<b>54</b>
	<b>Slide rail</b>	<b>56</b>
	<b>Steel slide rail</b>	<b>58</b>
	<b>Profile connector AL</b>	<b>60</b>
	<b>Assembly module AL</b>	<b>61</b>

## Section profile AL closed

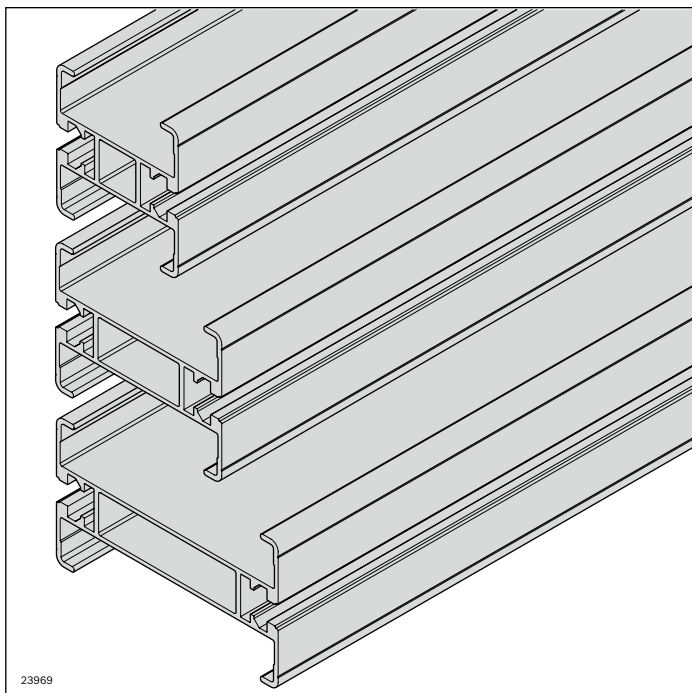

The section profile is the supporting element for the construction of straight conveyor sections and allows for the attachment of all required components.

- Size: 65, 90, 120

- ▶ Slot on the inside for attaching main components such as drive/return unit, curves, etc.
- ▶ Slot on the outside for fastening lateral guides, supports, or other accessories
- ▶ If necessary, lateral mounting of the slide rails with centering grooves as drill guide

- ▶ Special constructions can be attached quickly and simply with components from the modular aluminum framing system through the 10 mm outside slot.

Required accessories:

- Slide rail, see page 56
- Profile connector, see p. 60

Optional accessories:

- Cover profile, see p. 62

Material:

Aluminum; natural, anodized



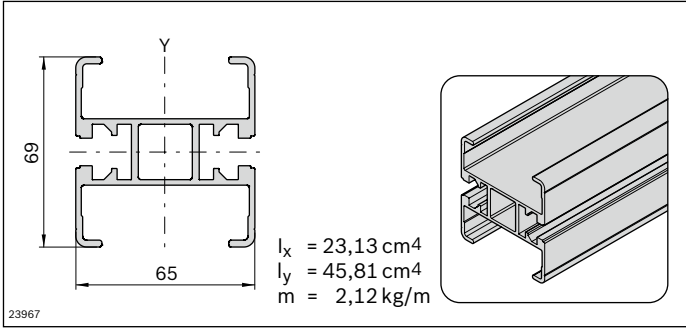

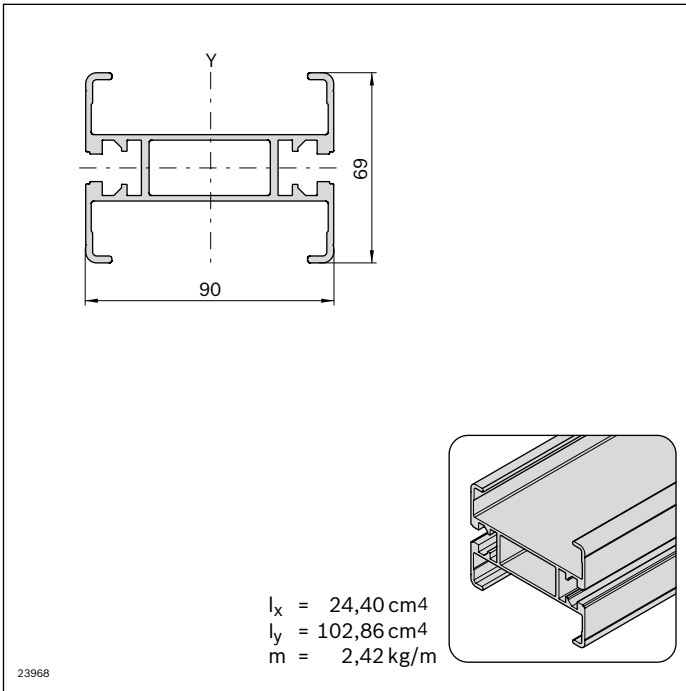

Section profile VFplus 65 AL	L (mm)	No.
 12 pcs	6070	<b>3 842 546 643</b>
1 pcs	50 ... 6000	<b>3 842 996 022/L</b>

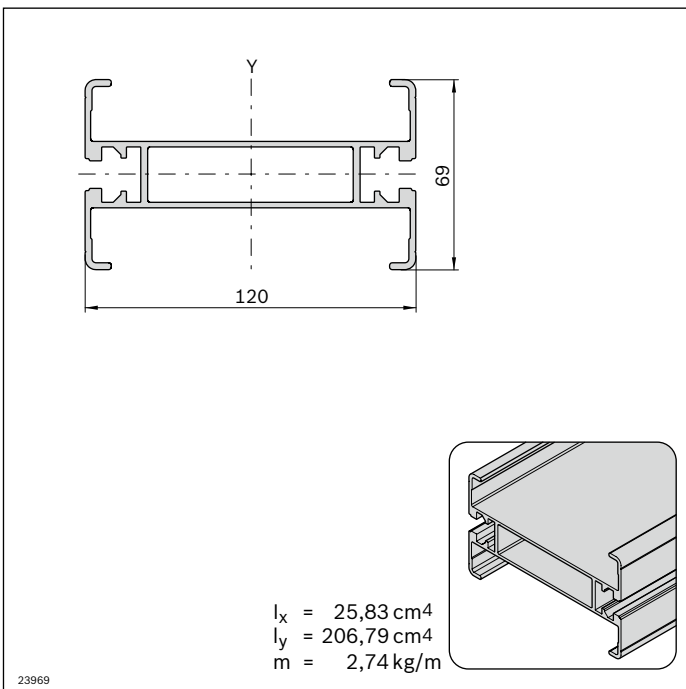

Section profile VFplus 90 AL	L (mm)	No.
 12 pcs	6070	<b>3 842 546 644</b>
1 pcs	50 ... 6000	<b>3 842 996 023/L</b>



Section profile VFplus 120 AL	L (mm)	No.
 6 pcs	6070	<b>3 842 546 645</b>
1 pcs	50 ... 6000	<b>3 842 996 024/L</b>

3

# Section profile AL open

## Cross connector AL

## Support profile AL

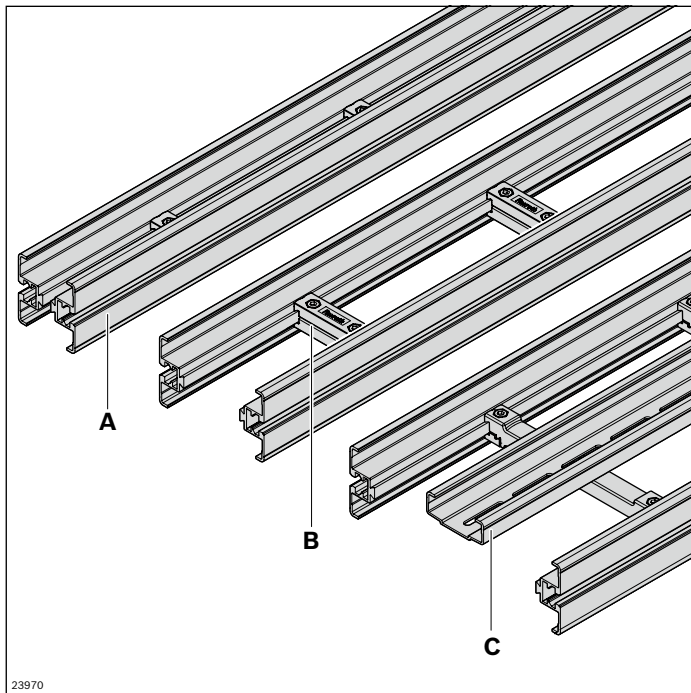

### AL open section profile (A)

- ▶ Slot on the inside for attaching main components such as drive/return unit, curves, etc.
- ▶ A 10 mm outside slot for simple fastening of lateral guides, leg sets, or components from the modular aluminum framing system
- ▶ If necessary, lateral mounting of the slide rails with centering grooves as drill guide

#### Required accessories:

**A:** Cross connector, see p. 54; slide rail, see p. 56; profile connector, see p. 60; support profile from size 160, see p. 55

#### Optional accessories:

**A:** Cover profile, see p. 62

The open construction of the section profile (**A**) allows dirt or foreign particles to be removed directly. Two open section profiles, linked by cross connectors, are needed to construct a conveyor section. A support profile is necessary for sizes 160 and over.

- Same profile cross-section across all sizes (65-320)

The cross connector (**B**) is the connection of two profile halves to make an open section profile. Using cross connectors of different lengths determines the size.

From size 160, a support profile (**C**) is required. The support profile is fastened to the existing cross connectors.

### Cross connector AL (B)

- ▶ Cross connector with mounting option for support profile

### Support profile AL (C)

- ▶ Elongated holes at regular intervals for fastening

#### Scope of delivery:

**B:** Complete, incl. screw for attaching the support profile



#### Condition on delivery:

**A, B:** Not assembled

#### Material:

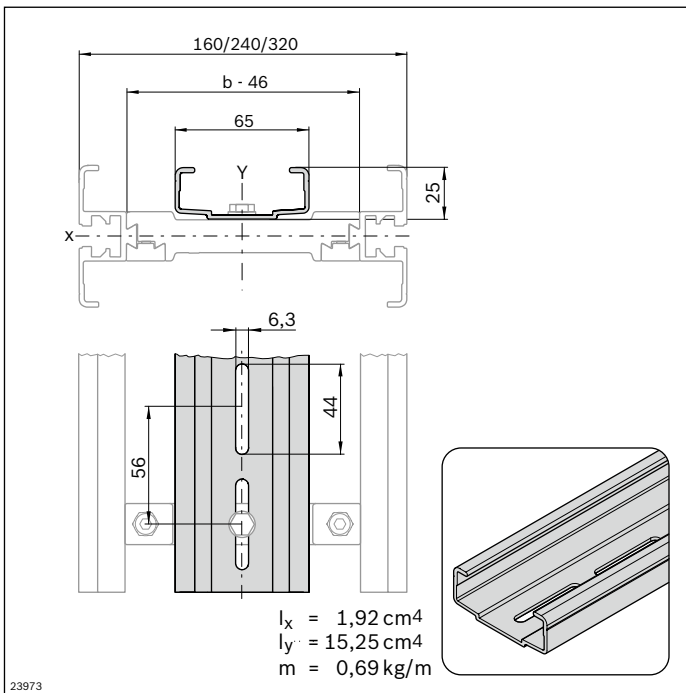
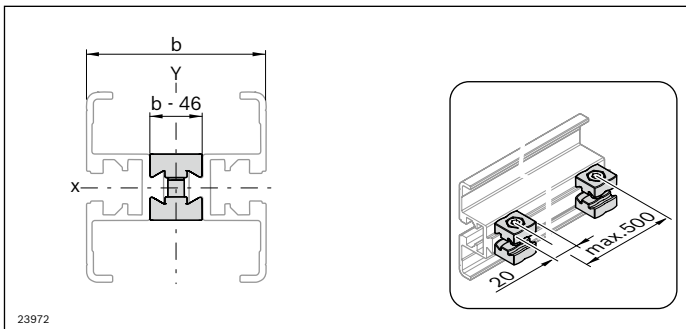
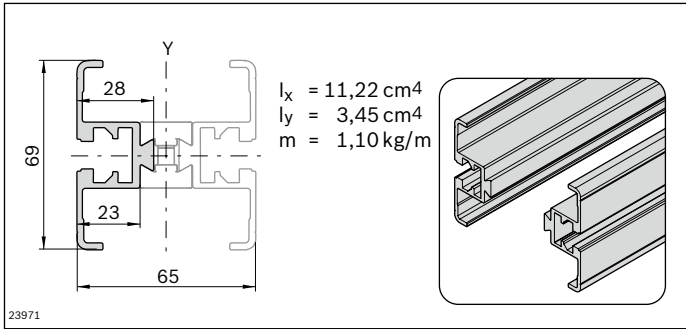
- **A, C:** Aluminum; natural, anodized
- **B:** Aluminum, die-cast



Section profile VFplus AL open		L (mm)	No.
	12 pcs	6070	<b>3 842 546 647</b>
	2 pcs	3000	<b>3 842 546 670</b>
	1 pcs	50 ... 6000	<b>3 842 996 026/L</b>

Cross connector AL	b (mm)		No.
VFplus 65	65	10	<b>3 842 546 672</b>
VFplus 90	90	10	<b>3 842 546 673</b>
VFplus 120	120	10	<b>3 842 546 674</b>
VFplus 160	160	10	<b>3 842 546 675</b>
VFplus 240	240	10	<b>3 842 546 676</b>
VFplus 320	320	10	<b>3 842 546 677</b>

Support profile VFplus AL		L (mm)	No.
	12 pcs	6070	<b>3 842 546 705</b>
	1 pcs	3000	<b>3 842 547 904</b>
	1 pcs	75 ... 6000	<b>3 842 996 028/L</b>

## Slide rail

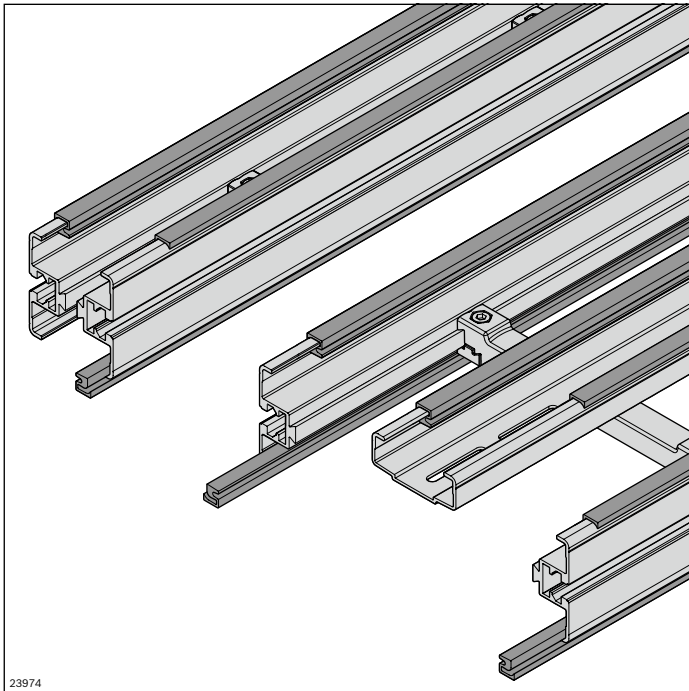

- ▶ Easy assembly - simply clip onto the section profile
- ▶ Secured against axial shifting with lateral screw fittings
- ▶ Gliding surface machining: not required
- ▶ Material
  - Premium, Advanced slide rails: FDA CFR 21
  - with Basic slide rail: EU 10/2011, FDA CFR 21
- ▶ One cross-section for all AL and STS section profiles

### Required accessories:

- Slide rail assembly tool, see page 264
- Sheet metal screw 2.9x9.5 DIN 7982;  
DIN EN ISO 7050 see page 57  
1 screw for each slide rail section

### Material:

PE-UHMW

The slide rail is clipped into the section profile and guides the conveyor chain.

Lateral securing means the gliding surface does not need to be machined. Abrasion and noise levels are thus reduced to a minimum.

Three slide rails with different main areas of application are available:

- Basic: straight sections and curve wheels,  $v_{\max}$  60 m/min
- Advanced: Sections with sliding curves,  $v_{\max}$  60 m/min, cleanroom
- Premium: Sections with sliding curves,  $v_{\max}$  100 m/min, cleanroom

For the selection of slides rails, see the “Technical data” chapter on page 278. See also ESD slide rails on page 178 and steel slide rail on page 58.

Extend the slide rail over the component interfaces to ensure minimum wear and noise emissions. Interruptions to the profile or component connection must be avoided. If an interruption is necessary after 10 m, the slide rail must be attached laterally with a sheet metal screw (**A**).

**Note:** After the sliding curves, an interruption is provided as an expansion joint in the inner curve area.

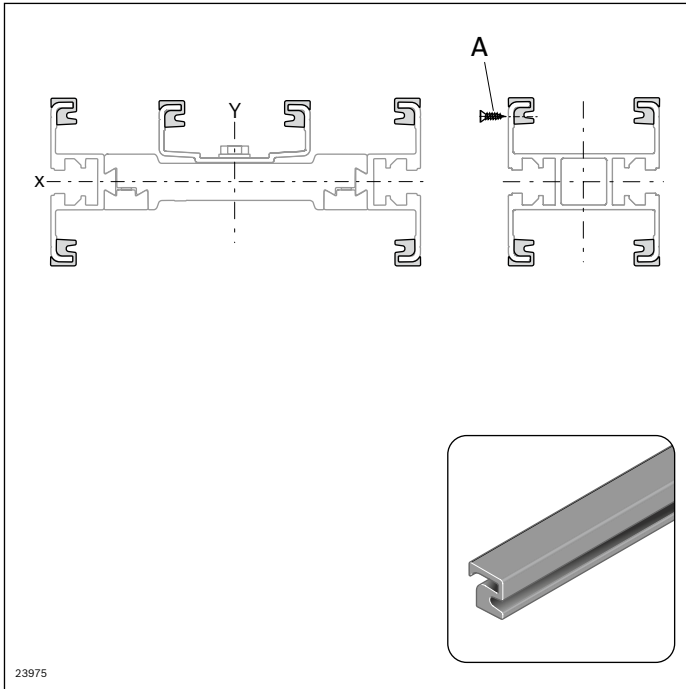

Slide rail VFplus	Color	L (mm)	 No.
Premium	gray	30000	1 <b>3 842 546 116</b>
Advanced	white	30000	1 <b>3 842 549 727</b>
Basic	blue	30000	1 <b>3 842 549 730</b>

See also ESD slide rail, see page 178  
and steel slide rail, see page 58.

Sheet metal screw	 No.
<b>A</b>	100 <b>3 842 547 908</b>



## Steel slide rail

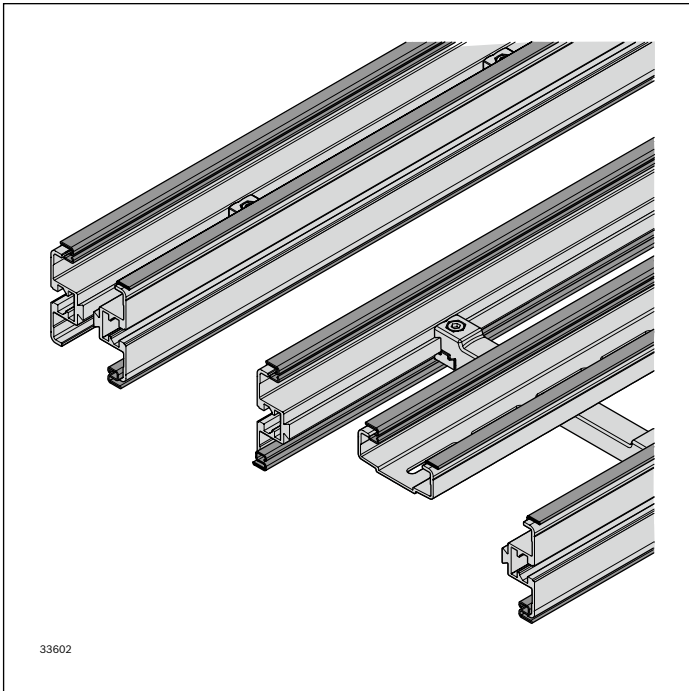

- ▶ Easy assembly - simply clip onto the section profile
- ▶ Secured against axial shifting via lateral fixing
- ▶ Gliding surface machining: not required
- ▶ One cross-section for all AL and STS section profiles

### Required accessories:

- Pop rivet D3x8 mm, see page 59
- Number of rivets:
  - Straight slide rail section: 1 rivet
  - 90° curve: 3 rivets
  - 180° curve: 6 rivets

### Material:

Stainless steel

The steel slide rail is suitable for use in abrasive ambient conditions (reduced service life of the conveyor chain). It is clipped in to the section profile and fixed in place at the side via a pop rivet.

The side fixing reduces the friction and the noise level to a minimum. The steel slide rail butt joints are merely chamfered. The Advanced slide rail is used in the lower run of the curve wheels.

- Steel slide rail straight section (**A**)
- Steel slide rail curve wheels (**B**) 90°, 180°; other angles on request
- Dry, wet and abrasive environment
- Size:
  - Straight section: all track widths
  - Curve wheel 65-90; 120 on request
- Not suitable for use in horizontal sliding curves
- Only Advanced or Premium slide rails can be used in vertical curves

**Note:** Ensure gap-free assembly (without expansion joint), as foreign bodies could otherwise get trapped in the gap and damage the chain.

**Note:** Non-destructive dismantling of the steel slide rail is not possible. A target separation point of the system must therefore be defined before assembly. Overlap the steel slide rail by 10 ... 15 mm on the section profile separation point. This ensures that it is still possible to pull apart the two parts.

Extend the steel slide rail over the component interfaces to ensure minimum wear and reduced noise emissions. Interruptions directly on the profile or component connection must be avoided.

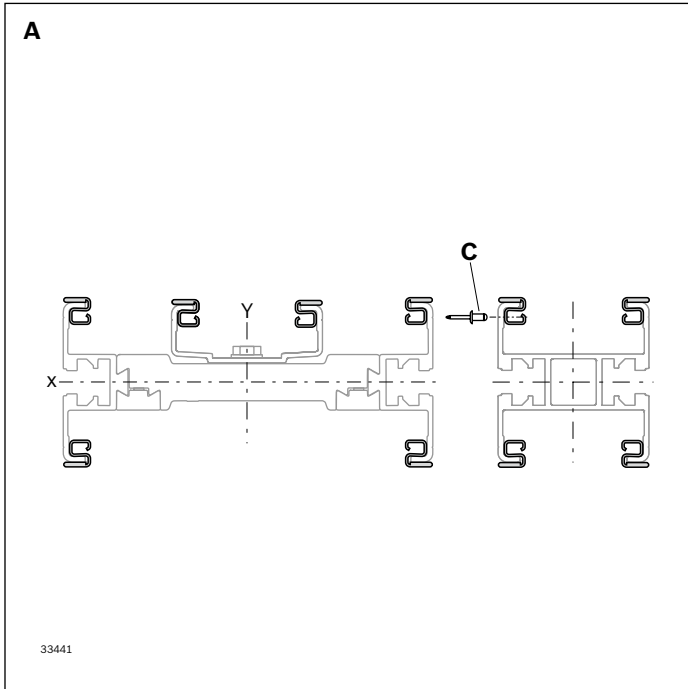

Slide rail VFplus steel	L (mm)	No.
A Straight section	3000	1 <b>3 842 552 970</b>

Pop rivet	No.
C	100 <b>3 842 557 004</b>

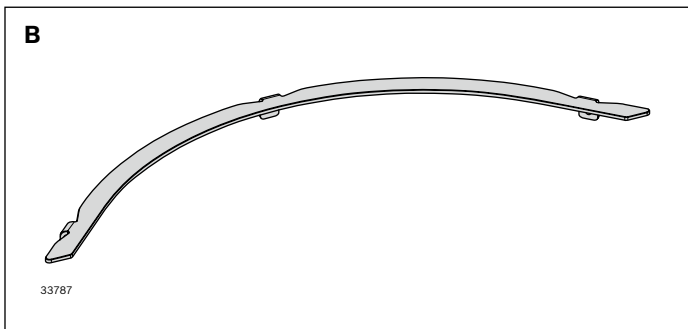

Steel slide rail; curve wheel VFplus 65	No.
B Steel 90°	1 <b>3 842 552 972</b>
B Steel 180°	1 <b>3 842 552 973</b>

Steel slide rail; curve wheel VFplus 90	No.
B Steel 90°	1 <b>3 842 552 974</b>
B Steel 180°	1 <b>3 842 552 975</b>

Pop rivet	No.
C	100 <b>3 842 557 004</b>

# Profile connector AL

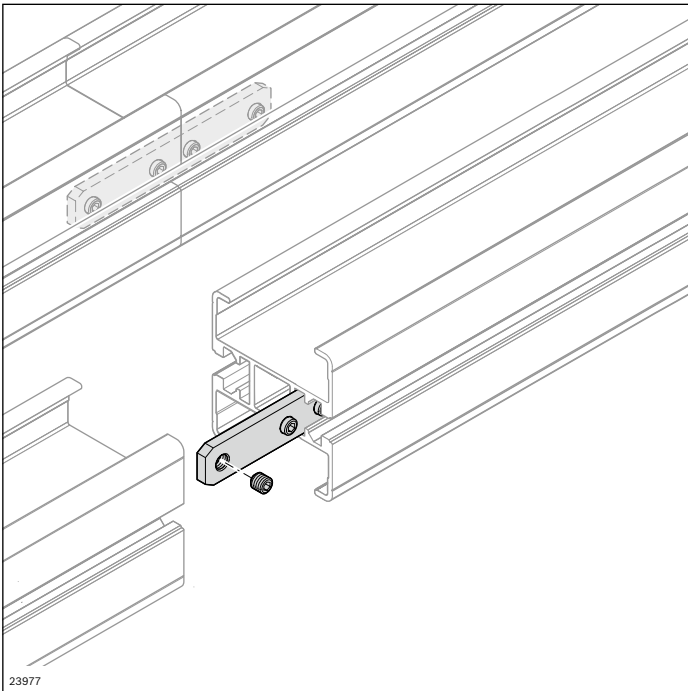

Two profile connectors are used to connect the end faces of the section profiles. The profile connector is fixed in the interior slot, so that the slot on the outside is available for all kinds of superstructures.

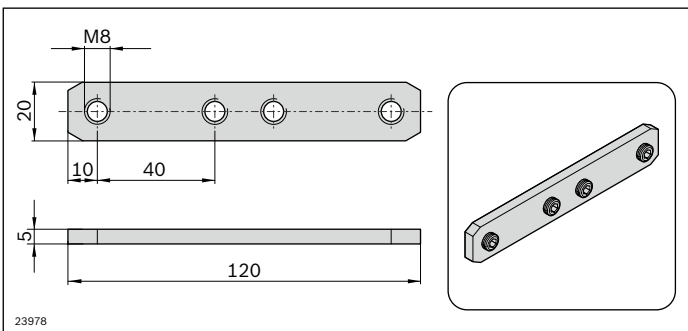

<b>Profile connector VFplus AL</b>	 <b>No.</b>
	10 <b>3 842 530 277</b>

Scope of delivery:  
Complete

Condition on delivery:  
Screws pre-assembled and secured

Material:  
steel; galvanized

# Assembly module AL

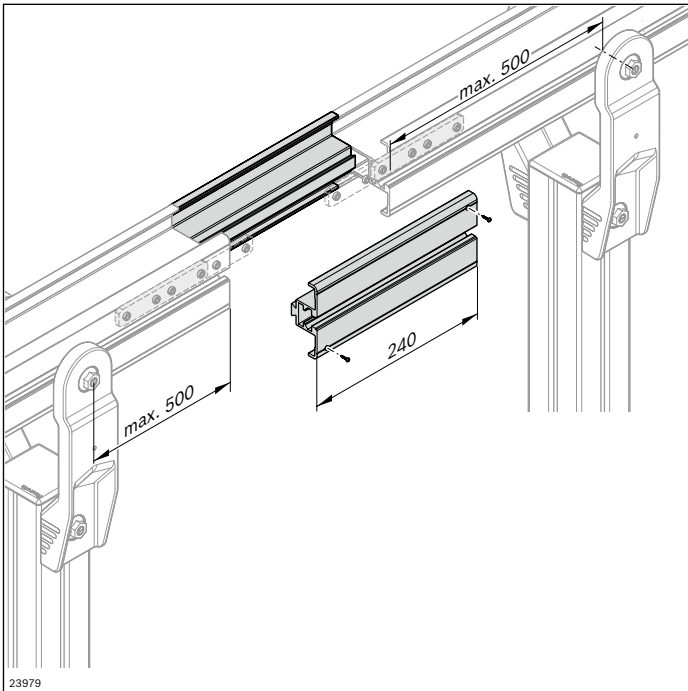

The assembly module is used for inserting and closing or opening the chain. It can be installed at any point on the conveyor section that is easy to access in operation. The assembly module is intended for sections with drives without a chain bag (e.g. wedge conveyor, curve wheel drive). For attachment options, see matrix on page 289

- Max. distance from the nearest leg sets on both sides is 500 mm
- The support profile with slide rail is not interrupted in the assembly module, enhancing smooth running
- Slide rail interruption is only required on the side to be opened

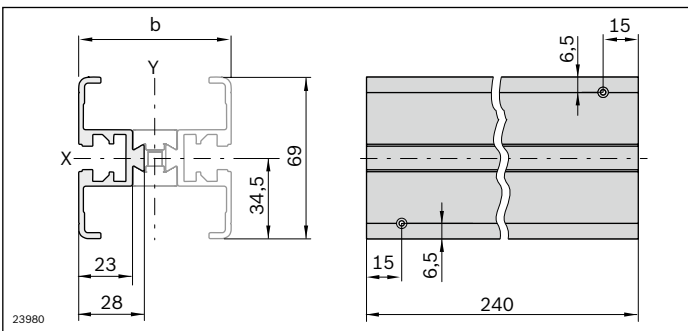

	L (mm)	No.
Assembly module VFplus AL		1 <b>3 842 547 899</b>
Slide rail VFplus Premium	30000	1 <b>3 842 546 116</b>
Slide rail VFplus Advanced	30000	1 <b>3 842 549 727</b>
Slide rail VFplus Basic	30000	1 <b>3 842 549 730</b>
Slide rail VFplus steel	3000	1 <b>3 842 552 970</b>
Slide rail VFplus ESD	30000	1 <b>3 842 557 000</b>

Required accessories:  
Slide rail, see p. 56, 58, 178

Optional accessories:  
Cover profile, see p. 62

Scope of delivery:  
Incl. 4 profile connectors and sheet-metal screws for fastening the slide rail

Condition on delivery:  
In single parts

Material:  
- Aluminum; natural, anodized  
- Profile connector: steel; galvanized

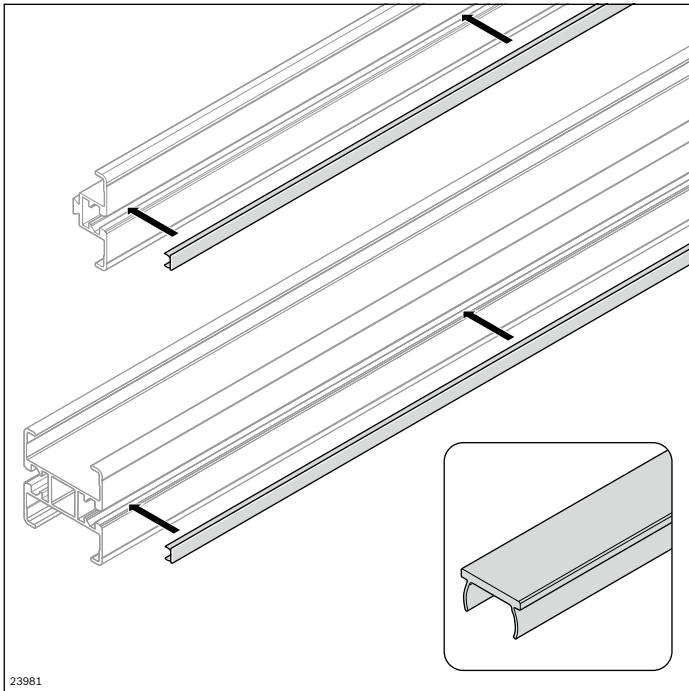

## Cover profile



Cover profile to improve system design, to fix cables routed in the profile slot, and to protect the profile slot against contamination

**Material:**

- AL: Aluminum; natural, anodized
- PVC: Hard PVC; colored

Cover profile	L (mm)	No.
 AL <small>00109368</small>	2000	10 <b>3 842 523 258</b>
 PVC <small>19502</small>		
black	2000	10 <b>3 842 146 901</b>
colorless	2000	10 <b>3 842 191 182</b>
RAL 7035 (light gray)	2000	10 <b>3 842 518 367</b>
RAL 3020 (red)	2000	10 <b>3 842 518 368</b>
RAL 1023 (yellow)	2000	10 <b>3 842 518 369</b>
RAL 5010 (blue)	2000	10 <b>3 842 538 955</b>
RAL 2004 (orange)	2000	10 <b>3 842 538 957</b>



# Flange nut T-bolt

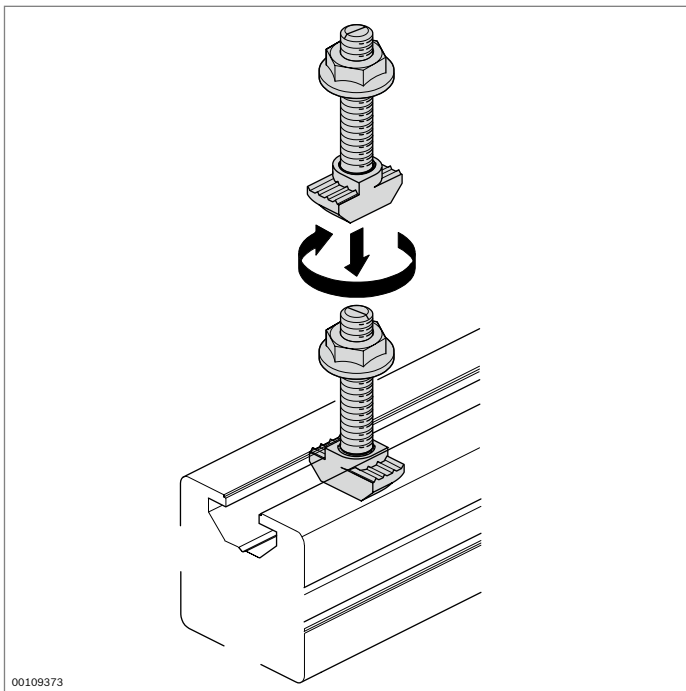

00109373

Fastening elements for mounting accessories on the profile slot

- Secure and conductive connection
- The notch at the end of the screw is used to detect the position and identify the correct positioning
- Profile finishing: not required

There is a selection of different mounting options in the MGE catalog.

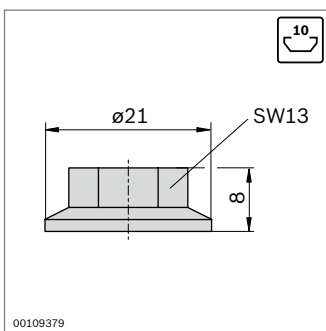

00109379

Flange nut	Groove	M	ESD	No.
	10	M8	100	3 842 345 081

Material: steel; galvanized

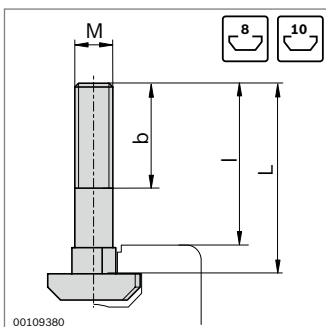

00109380

Groove	$F_{max}$
10	6000 ... 18000 N <sup>1)</sup>

<sup>1)</sup> Dependent on the profile (see also "Technical data" in the MGE catalog)

T-bolt	Groove	MxL	b (mm)	l (mm)	ESD	No.
	10	M8x20	14	14	100	3 842 528 715
		M8x25	19	19	100	3 842 528 718
		M8x30	24	24	100	3 842 528 721
		M8x40	22	34	100	3 842 528 724
		M8x50	22	44	100	3 842 528 727

Material: steel; galvanized

# Collar screw T-nut

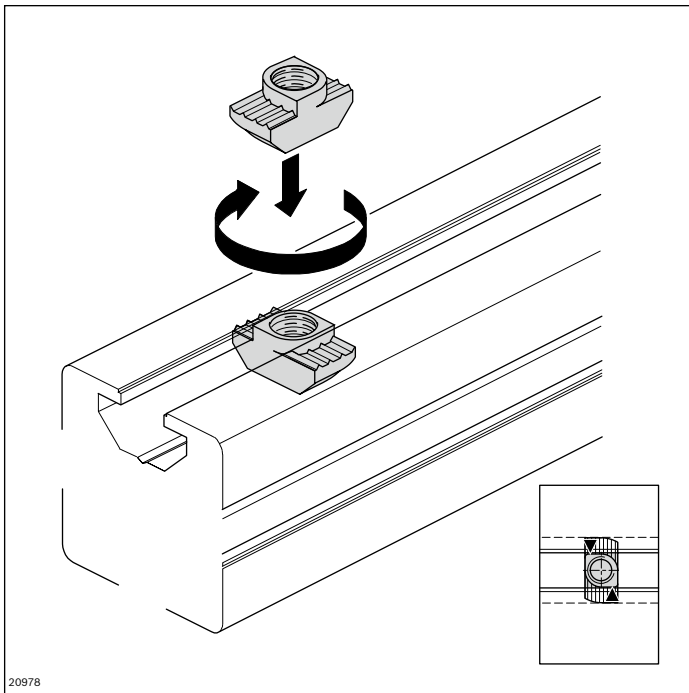

Fastening elements for mounting accessories on the profile slot

- Standard element for secure, conductive connections
- Stop for correct positioning in the profile slot
- Profile finishing: not required

T-nut, 10 mm slot	Groove	M	ESD	No.
steel; galvanized	10	M4	⚡	100 3 842 530 281
		M5	⚡	100 3 842 530 283
		M6	⚡	100 3 842 530 285
		M8	⚡	100 3 842 530 287

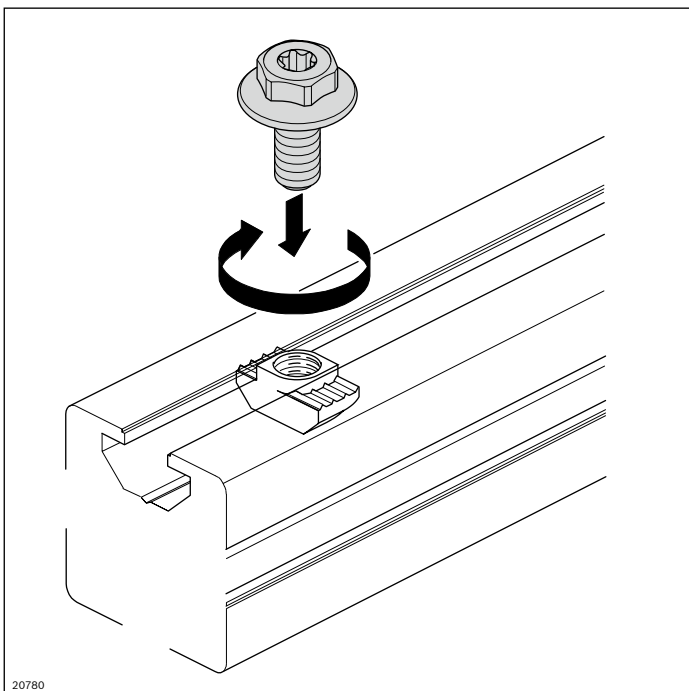

- Collar screw with multi-function head for tightening with ring/open-end wrench (WS 13) or Torx screwdriver (T40)
- Machine tightening possible
- Preferably to be used for fastening brackets
- Quick and simple assembly
- Excellent force transmission via the wide flange
- With Polyfleck to secure the T-nut

Tools: Allen keys

Collar screw	M	L (mm)	ESD	No.
M8x18-SW13-T40 <sup>1)</sup>	M8	18	⚡	100 3 842 541 246
M8x20-SW13-T40 <sup>2)</sup>	M8	20	⚡	100 3 842 541 409

<sup>1)</sup> For 40/40 and 60/60 brackets

<sup>2)</sup> For all other brackets for 10 mm slot

Material: steel; galvanized





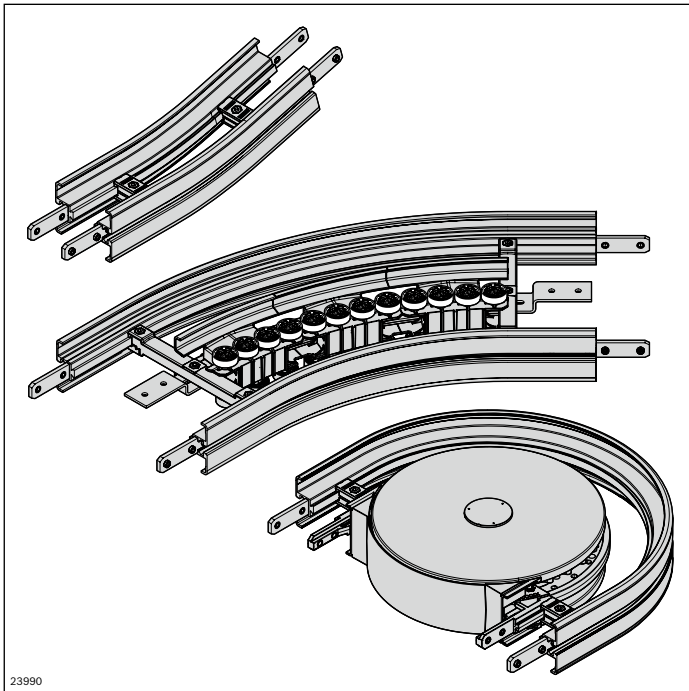

## AL curves



- ▶ Reduced friction on curve wheels and patented roller curves to minimize wear, meaning longer sections
- ▶ Components subject to constant friction feature FDA-compliant materials
- ▶ Easy to clean thanks to ample draining surfaces
- ▶ Capable of accumulation
- ▶ Stainless steel ball bearings sealed on both sides with FDA-compliant special grease in curve wheels and patented roller curves
- ▶ Extension of the curve wheel to a curve wheel drive or alpine conveyer

Longer service life and reduced downtimes thanks  
to low-friction curve technology

	<b>Curve wheel AL</b> <b>AL protective cover for the curve wheel</b>	<b>68</b>
	<b>Roller curve horizontal AL</b>	<b>70</b>
	<b>Sliding curve horizontal AL</b>	<b>72</b>
	<b>Vertical curve AL</b>	<b>74</b>



## Curve wheel AL

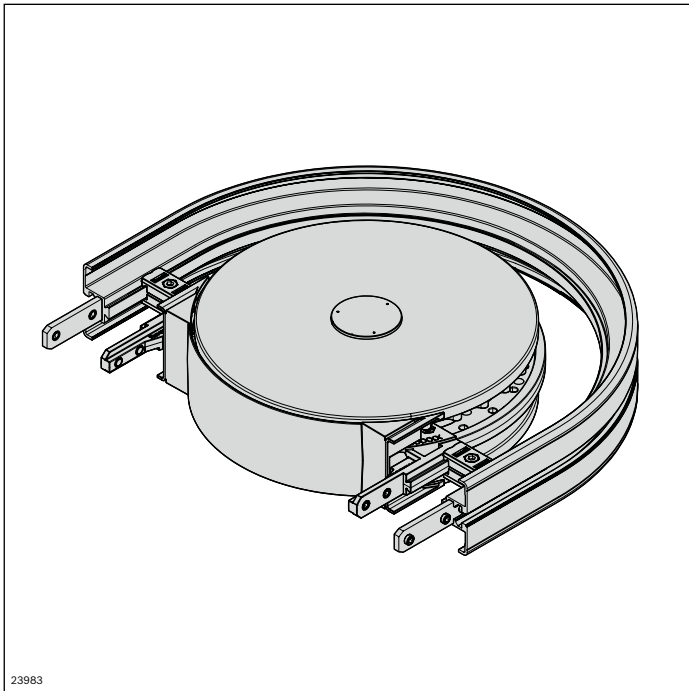

The curve wheel provides a horizontal direction change for the chain. It enables low-friction direction changes with very small radii.

For attachment options, see the matrix on page 289

- Size: 65, 90, 120
- Deflection angles see table on page 69, other deflection angles on request
- Suitable chain types: all
- For circuit systems without chain return in bottom run (using a curve wheel or connection drive), the appropriate cover must be used for personal safety reasons

**Note:** High-pressure cleaning of the ball bearings is not permitted.

See also Curve wheel AL ESD, page 180.

- ▶ Construction of inexpensive alpine conveyors by using an alpine conveyor connection kit
- ▶ Stainless steel ball bearings, with sealing on both sides and FDA-compliant lubrication
- ▶ Surfaces in contact with chain made of FDA-compliant material

Scope of delivery:

Incl. fastening material for mounting to AL section profiles

Material:

- Housing: Aluminum, die-cast
- Chain wheel: PA; white
- Ball bearings: Stainless steel/ FDA

- ▶ No interfering contours above chain plate height
- ▶ Can be used horizontally and vertically (for wedge conveyors)

Condition on delivery:

Fully assembled

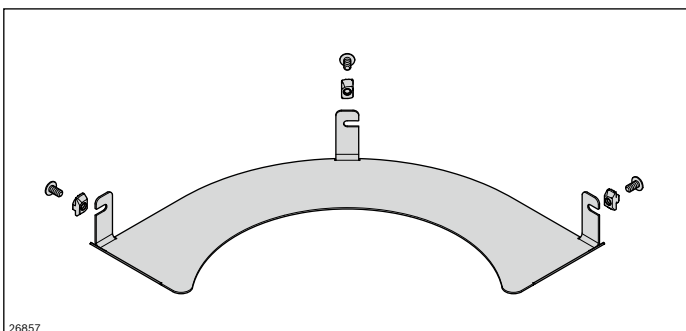
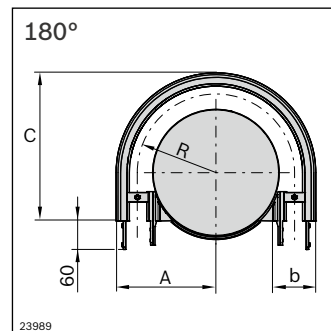
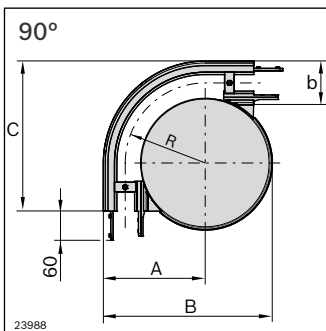
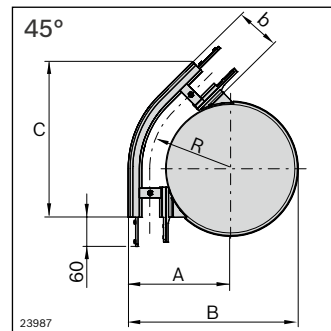
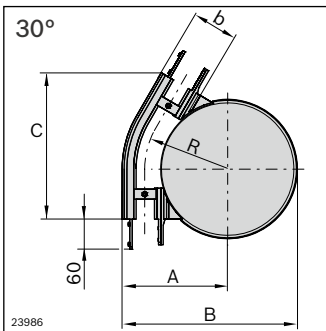
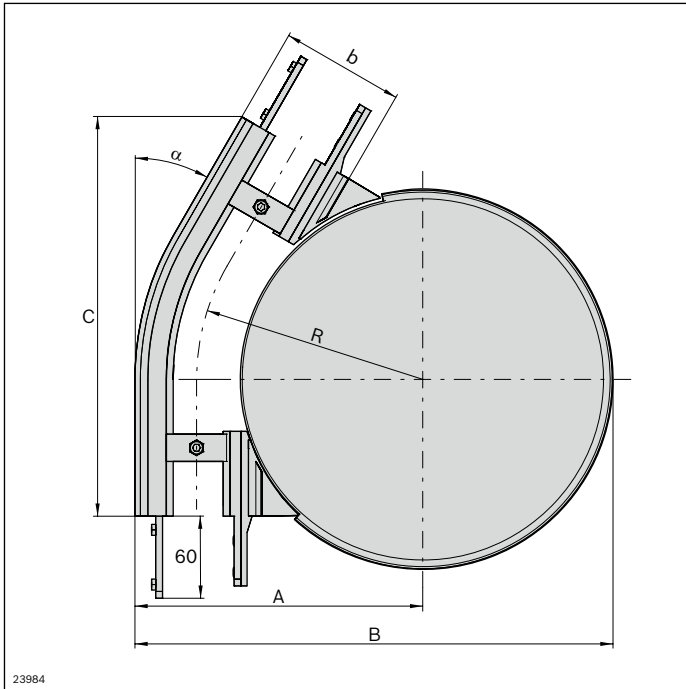

AL curve wheel	$\alpha$ (°)	No.
VFplus 65	30	<b>3 842 547 048</b>
	45	<b>3 842 547 049</b>
	90	<b>3 842 547 050</b>
	180	<b>3 842 547 051</b>
VFplus 90	30	<b>3 842 547 052</b>
	45	<b>3 842 547 053</b>
	90	<b>3 842 547 054</b>
	180	<b>3 842 547 055</b>
VFplus 120	30	<b>3 842 547 056</b>
	45	<b>3 842 547 057</b>
	90	<b>3 842 547 058</b>
	180	<b>3 842 547 059</b>

b (mm)	$\alpha$ (°)	R (mm)	A (mm)	B (mm)	C (mm)
65	30	153.0	185.5	324.5	279.4
	45	153.0	185.5	324.5	301.9
	90	153.0	185.5	324.5	285.5
	180	153.0	185.5	–	285.5
90	30	165.5	210.5	349.5	291.9
	45	165.5	210.5	349.5	319.6
	90	165.5	210.5	349.5	310.5
	180	165.5	210.5	–	310.5
120	30	180.5	240.5	379.5	306.9
	45	180.5	240.5	379.5	340.8
	90	180.5	240.5	379.5	340.5
	180	180.5	240.5	–	340.5

Protective cover AL	$\alpha$ (°)	No.
VFplus 65	30°	<b>3 842 551 545</b>
	45°	<b>3 842 551 546</b>
	90°	<b>3 842 551 547</b>
	180°	<b>3 842 551 548</b>
VFplus 90	30°	<b>3 842 551 549</b>
	45°	<b>3 842 551 550</b>
	90°	<b>3 842 551 551</b>
	180°	<b>3 842 551 552</b>

## Roller curve horizontal AL

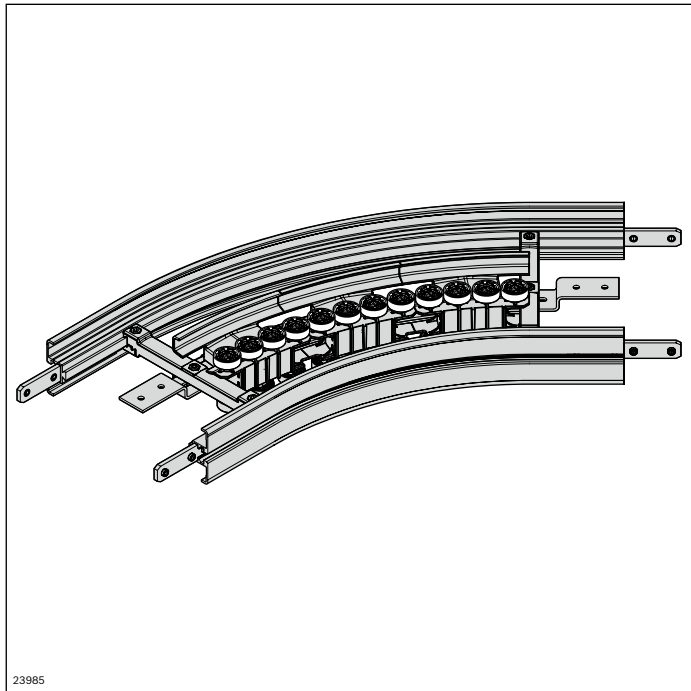

The low-friction roller curve provides a horizontal change in direction for the chain. Roller elements with ball bearings enable longer conveyor sections.

The service life of the chain is increased and system costs reduced.

For attachment options and length determination of the support profile, see matrix on page 289

- Size: 160, 240, 320
- Deflection angles, see table on p. 71
- Other deflection angles on request
- Suitable chain types: all
- Version with open section profiles

**Note:** High-pressure cleaning of the ball bearings is not permitted.

- ▶ Patented roller elements for low-friction, quieter changes in chain direction
- ▶ Stainless steel ball bearings, with sealing on both sides and FDA-compliant lubrication

- ▶ Surfaces in contact with chain made of FDA-compliant materials

Required accessories:

Slide rail: Length calculation, see page 278

Scope of delivery:

Incl. fastening material for mounting to the AL section profile

Condition on delivery:

Fully assembled

Material:

- Profile: aluminum, anodized
- Roller carrier: PA66
- Ball bearings: Stainless steel/ FDA
- Connector: steel; galvanized
- Rollers: PA

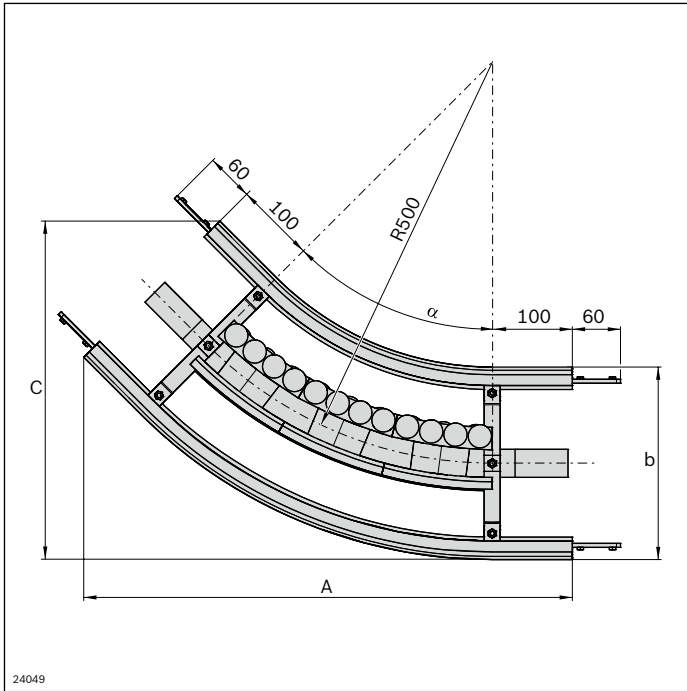

Roller curve AL	$\alpha$ (°)	No.
VFplus 160	30	<b>3 842 547 060</b>
	45	<b>3 842 547 061</b>
	90	<b>3 842 547 062</b>
	180	<b>3 842 547 063</b>
VFplus 240	30	<b>3 842 547 064</b>
	45	<b>3 842 547 065</b>
	90	<b>3 842 547 066</b>
	180	<b>3 842 547 067</b>
VFplus 320	30	<b>3 842 547 068</b>
	45	<b>3 842 547 069</b>
	90	<b>3 842 547 070</b>
	180	<b>3 842 547 071</b>

3

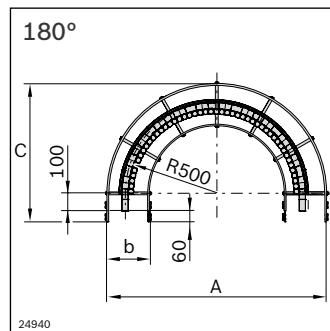
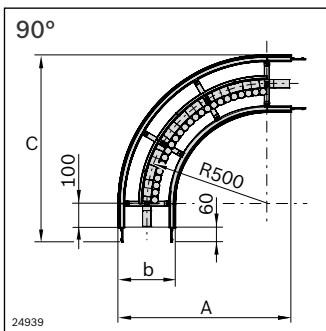
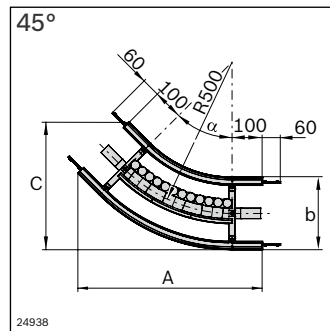
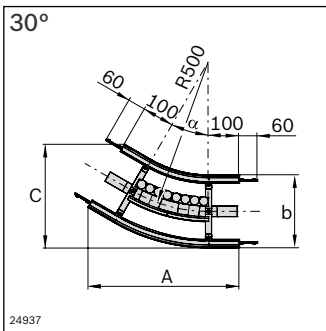

b (mm)	$\alpha$ (°)	A (mm)	C (mm)
160	30	476.6	266.3
	45	580.8	353.7
	90	680.0	680.0
	180	1160.0	680.0
240	30	496.6	340.9
	45	609.1	422.0
	90	720.0	720.0
	180	1240.0	720.0
320	30	516.6	415.6
	45	637.4	490.3
	90	760.0	760.0
	180	1320.0	760.0

## Sliding curve horizontal AL



The sliding curve provides a horizontal change in direction for the chain, for when there is not enough space for a curve wheel or the speeds or product dimensions do not permit conveying over a curve wheel. The sliding curve is used to reduce noise at high speeds or when transporting long products in wedge conveyors. The chain tensile force is increased through the ensuing friction.

For attachment options, see the matrix on page 289

- Size: 65, 90, 120
- Deflection angles and radii see table on p. 73, other deflection angles and radii on request
- Suitable chain types: all
- Version with open section profiles
- Requires the use of the Advanced or Premium slide rails

### Required accessories:

Slide rail: Length calculation, see page 278

### Scope of delivery:

Incl. fastening material for mounting to AL section profiles

### Condition on delivery:

Fully assembled

### Material:

- Profile: aluminum, anodized
- Profile connector: steel; galvanized
- Cross connector: Aluminum, die-cast



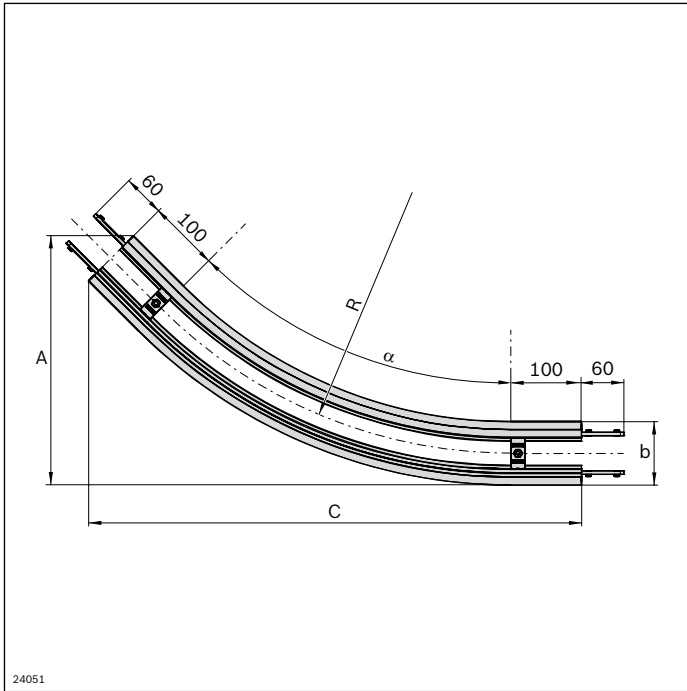

Sliding curve horizontal AL	$\alpha$ (°)	R (mm)	No.
VFplus 65	30	700	<b>3 842 547 072</b>
	45	700	<b>3 842 547 073</b>
	90	700	<b>3 842 547 074</b>
VFplus 90	45	500	<b>3 842 547 075</b>
	90	500	<b>3 842 547 076</b>
	30	700	<b>3 842 547 077</b>
	45	700	<b>3 842 547 078</b>
	90	700	<b>3 842 547 079</b>
VFplus 120	30	700	<b>3 842 547 080</b>
	45	700	<b>3 842 547 081</b>
	90	700	<b>3 842 547 082</b>

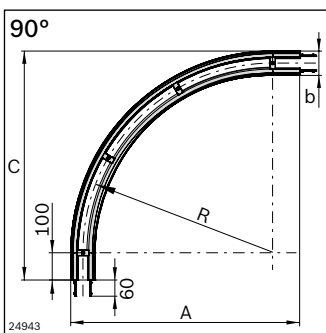
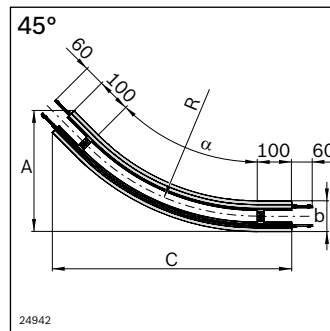
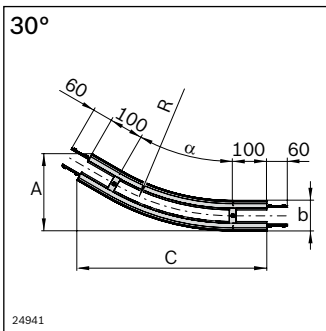

b (mm)	$\alpha$ (°)	R (mm)	A (mm)	C (mm)
65	30°	700	204.4	552.9
	45°	700	331.2	688.7
	90°	700	832.5	832.5
90	45°	500	294.0	556.1
	90°	500	645.0	645.0
	30°	700	227.8	559.1
	45°	700	352.6	697.5
120	90°	700	845.0	845.0
	30°	700	255.7	566.6
	45°	700	378.2	708.1
	90°	700	860.0	860.0

## Vertical curve AL

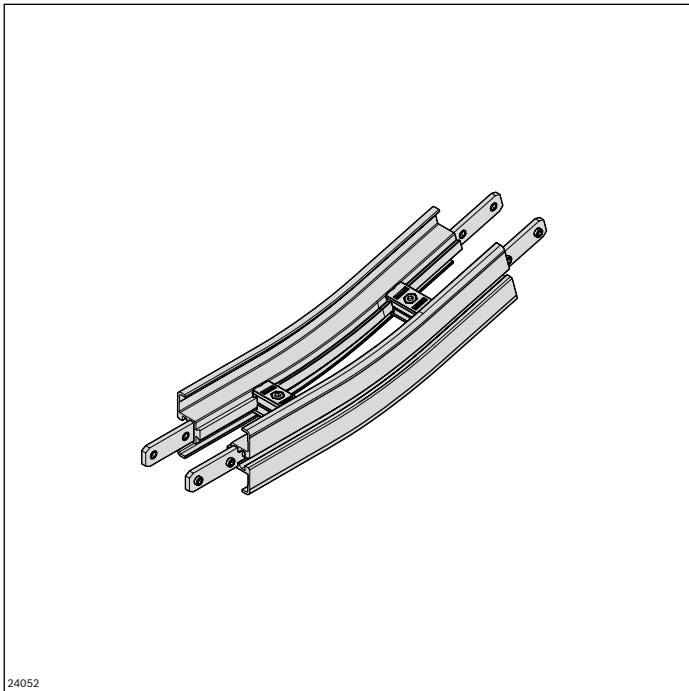

The vertical curve is used for the transition from a horizontal conveyor section to an ascending section and vice versa. The chain tensile force is increased through the ensuing friction.

A vertical curve of 5° is recommended for the infeed and outfeed on the wedge conveyor, especially with small products.

For attachment options, see the matrix on page 289

- Size: all track widths
- Deflection angles and radii see table on page 75, other deflection angles and radii on request
- Suitable chain types: all
- Version with open section profiles
- Requires the use of the Advanced or Premium slide rails

### Required accessories:

Slide rail: Length calculation, see page 278

### Scope of delivery:

Incl. fastening material for mounting to AL section profiles

### Condition on delivery:

Fully assembled

### Material:

- Profile: aluminum, anodized
- Profile connector: steel; galvanized
- Cross connector: Aluminum, die-cast
- Support profile from size 160: Stainless steel, 1.4301

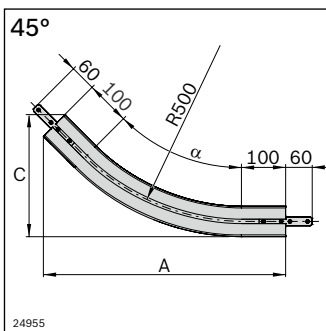
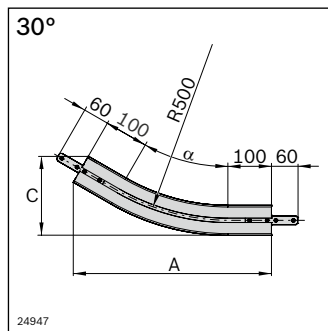
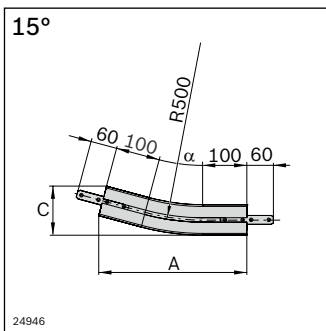
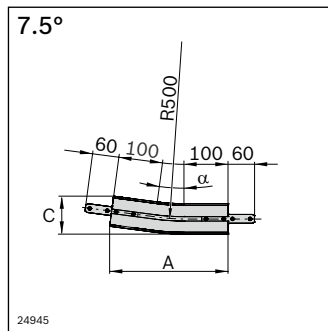
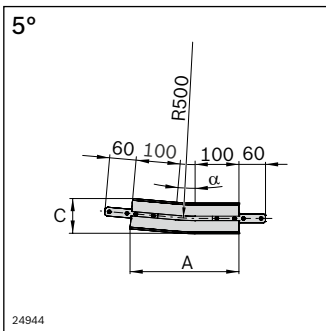
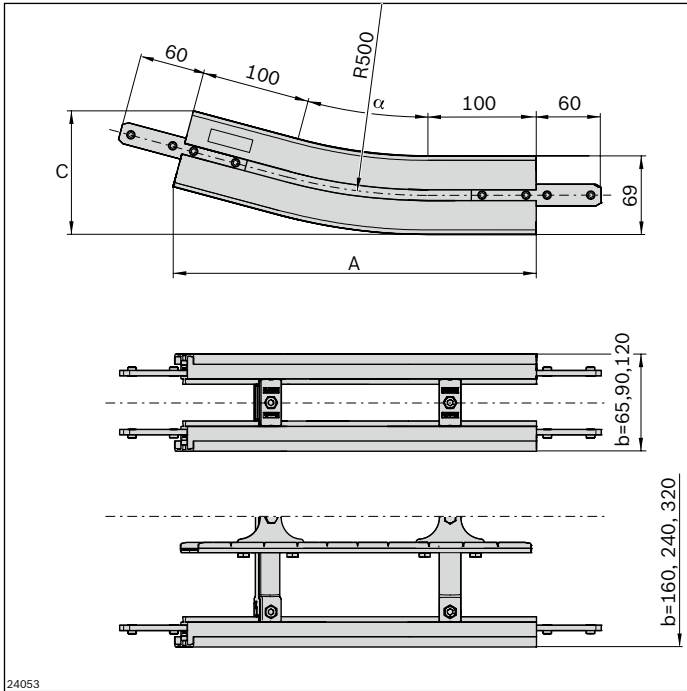

Vertical curve AL	$\alpha$ (°)	No.
VFplus 65	5	3 842 547 083
	7.5	3 842 547 084
	15	3 842 547 085
	30	3 842 547 086
	45	3 842 547 087
VFplus 90	5	3 842 547 088
	7.5	3 842 547 089
	15	3 842 547 090
	30	3 842 547 091
	45	3 842 547 092
VFplus 120	5	3 842 547 093
	7.5	3 842 547 094
	15	3 842 547 095
	30	3 842 547 096
	45	3 842 547 097
VFplus 160	5	3 842 547 098
	7.5	3 842 547 099
	15	3 842 547 100
	30	3 842 547 101
	45	3 842 547 102
VFplus 240	5	3 842 547 103
	7.5	3 842 547 104
	15	3 842 547 105
	30	3 842 547 106
	VFplus 320	5
7.5		3 842 547 108
15		3 842 547 109
30		3 842 547 110

b (mm)	$\alpha$ (°)	R (mm)	A (mm)	C (mm)
65-320	5	500	246.2	79.5
	7.5	500	268.9	86
	15	500	334.9	110.7
	30	500	453.9	181.4
65-160	45	500	548.7	276.1



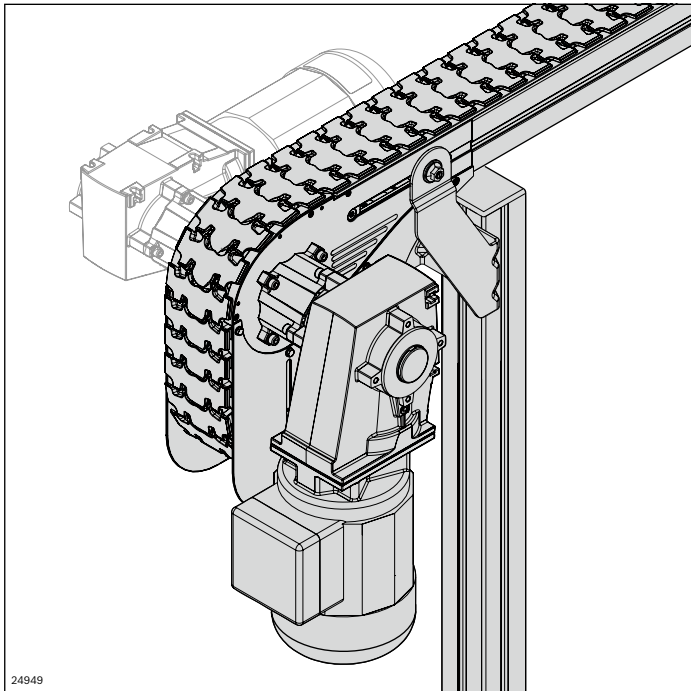











## Drive and return unit AL



- ▶ Basic units with interfaces on both sides for drive kit and transmission (active bridge)
- ▶ Free selection of the motor mounting position on site
- ▶ Configurable drive kit (standard gear motor or round shaft)
- ▶ Multi-track systems with standard components possible
- ▶ Reduced noise emission due to slide rails guided in the drive/return unit
- ▶ In-stock, standardized components
- ▶ Side elements with slots for accommodating holders
- ▶ Pulling section; pushing or reversible operation on request

24949

High flexibility and short delivery times thanks to a novel drive concept

	<b>Basic unit AL head drive direct</b>	<b>80</b>
	<b>Basic unit AL Connection drive</b>	<b>82</b>
	<b>Basic unit with center drive</b>	<b>84</b>
	<b>Return unit AL Closed head drive AL</b>	<b>86</b>
	<b>90° return unit</b>	<b>88</b>
	<b>Basic unit Curve wheel drive AL</b>	<b>90</b>
	<b>Drive kit</b>	<b>92</b>
	<b>Drive kit curve wheel AL</b>	<b>94</b>
	<b>Frequency converter motec 8400</b>	<b>96</b>
	<b>Manual control unit Switch/potentiometer unit</b>	<b>99</b>
	<b>Transmission kit</b>	<b>100</b>
	<b>Connection kit active (A) bridge Connection kit passive (B) bridge</b>	<b>102</b>
	<b>Connection kit Synchronous drive, external motor/internal motor</b>	<b>104</b>
	<b>Alpine conveyor connection kit</b>	<b>106</b>



## Innovative drive concept

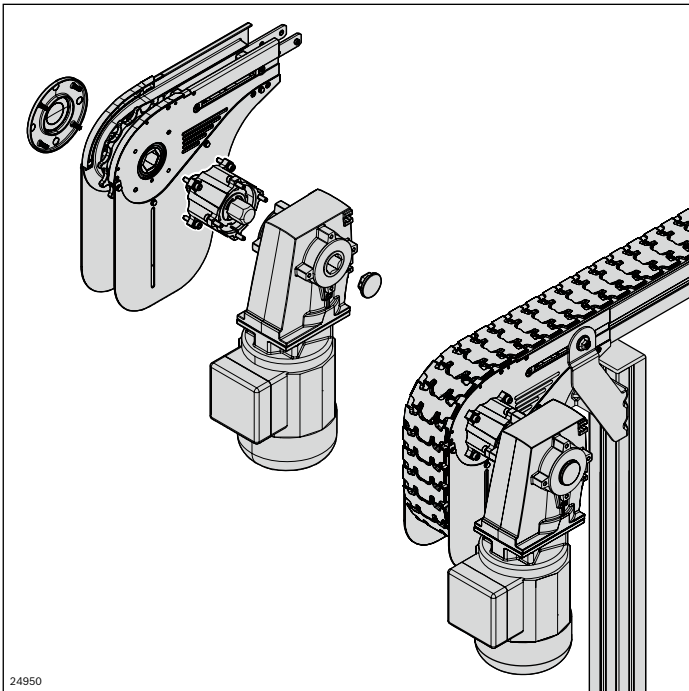

**Basic unit AL**  
(head drive direct, center  
or connection drive)  
**or return unit**

+

**Configurable drive kit**  
(standard gear motor or round shaft +  
transmission kit where applicable)

=

**complete drive**  
(transmission drive)

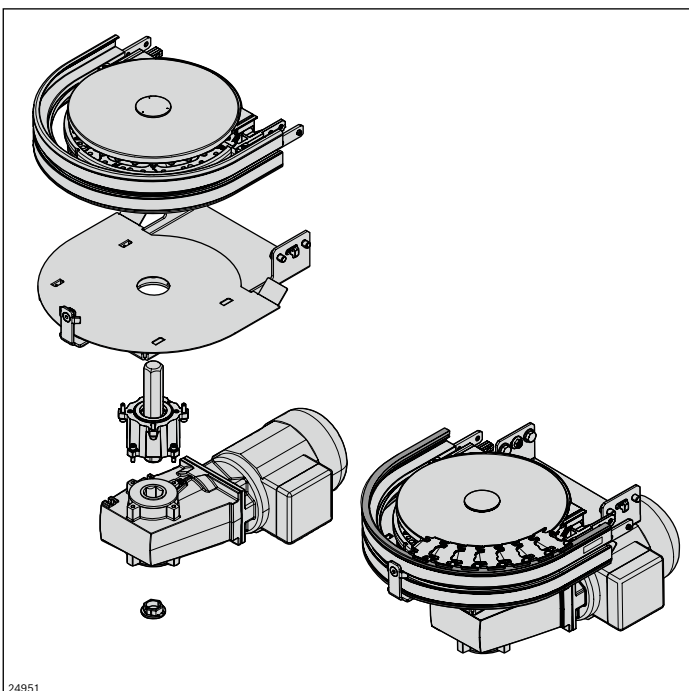

**Basic unit curve wheel AL**

+

**Configurable drive kit**  
(standard gear motor or round shaft)

=

**complete drive**

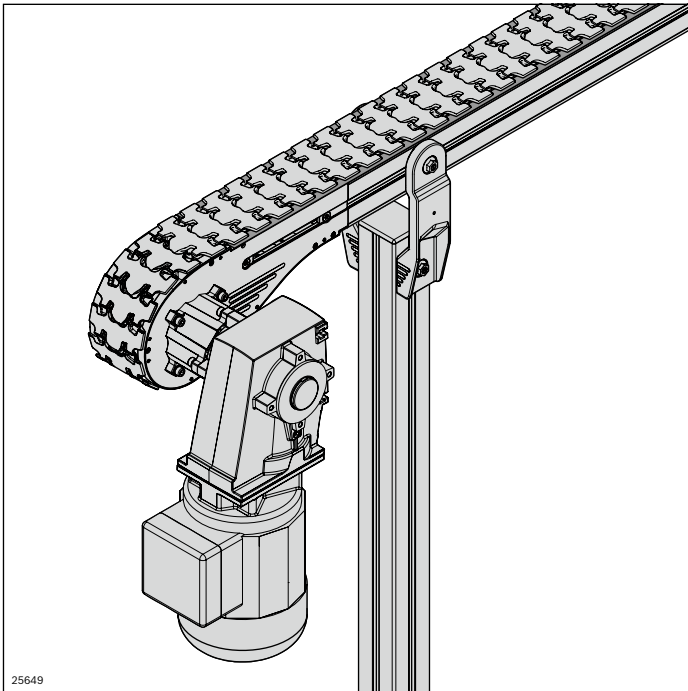

### The well thought-out drive solution enables high flexibility and planning freedom

The in-stock, standardized basic units

- Are quickly and easily combined with the configurable drive kit (standard gear motor or customer-specific interface) into a complete drive
- Guarantee fast availability of the few modular elements/ spare parts

The interface on both sides in the basic unit and return unit

- Enables a free selection of the motor mounting position on-site
- Offers additional transmission interfaces (active bridge)

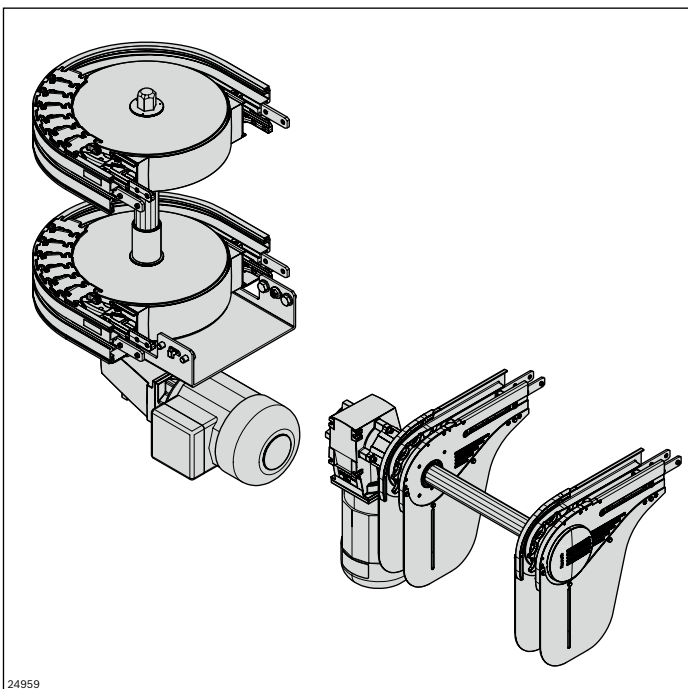

The standard drives and basic curve wheel units are easily to couple and enable straightforward implementation of multi-track systems and alpine conveyors

For attachment options, see the matrix on page 289

**Note:** High-pressure cleaning of the ball bearing areas is not permitted.

## Basic unit AL head drive direct

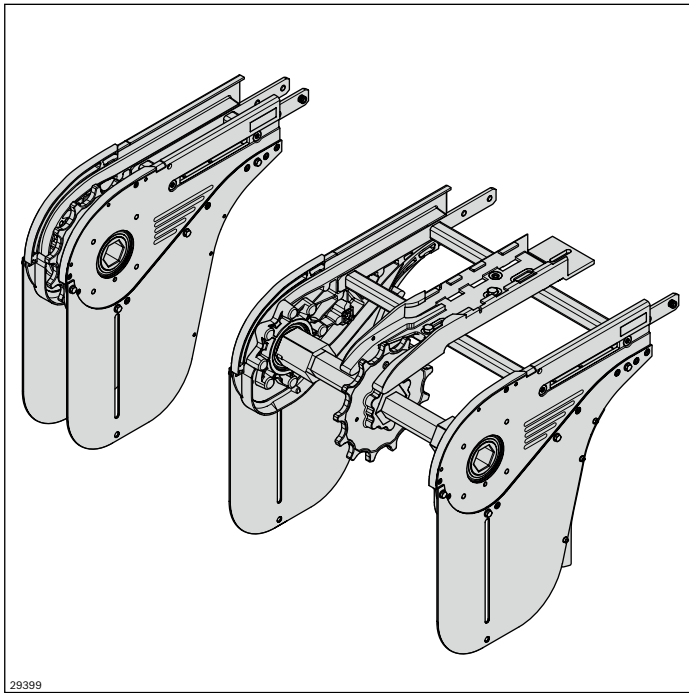

- ▶ Reduced noise emission due to slide rails guided in the head drive
- ▶ Installation of the drive kit possible on the right/left (motor, coupling, flange)
- ▶ Drive of a parallel conveyor section or bridge using a hexagonal hollow shaft integrated as standard

### Required accessories:

- Drive kit, see page 92
- Slide rail: Length calculation, see page 278
- Motor leg sets, see page 111/115

### Optional accessories:

- Active or passive bridge connection kits, see page 102
- Synchronous drive connection kit, see page 104
- Chain sprocket for inclined sections, see page 81
- Transmission kit, see page 100

Scope of delivery: Incl. fastening material

The basic unit is quickly turned into a head drive with variable mounting position by adding a drive kit. With the double-sided hexagonal hollow shaft, other components can be easily driven using a transmission (active bridge).

- Size: all track widths
- Suitable chain types: all
- Permissible chain tensile force:  $F_{\max} = 1250 \text{ N}$
- Section length:  $L \leq 30 \text{ m}$
- Conveying speed:  $v_N = 2 \dots 60 \text{ m/min}$ , other speeds available on request
- Chain bag to compensate for chain elongation during service life
- Not suitable for reversible operation

**Note:** A chain sprocket must be used to limit the chain slipping back on inclined sections.

- ▶ Stainless steel ball bearings, with sealing on both sides and FDA-compliant lubrication
- ▶ Implementation of parallel sections with gap dimension down to zero
- ▶ Side elements with slot to attach holders for lateral guides, or similar

### Condition on delivery:

Assembled: Chain fender enclosed

### Material:

- Housing: Die-cast aluminum, powder-coated, silver
- Chain wheel: PA
- Chain guide: PA
- Connector: steel; galvanized
- Hexagonal shaft  
up to size 160: PA  
from size 160: Stainless steel + PA
- Ball bearings: Stainless steel/ FDA

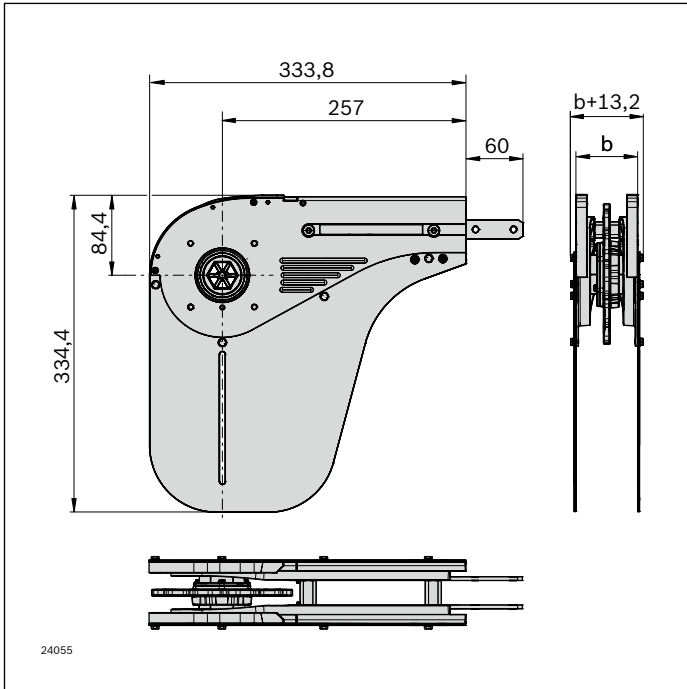

Basic unit AL	No.
VFplus 65 direct	3 842 546 120
VFplus 90 direct	3 842 546 121
VFplus 120 direct	3 842 546 122
VFplus 160 direct	3 842 546 123
VFplus 240 direct	3 842 546 124
VFplus 320 direct	3 842 546 125

Order the drive kit in addition to the AL basic unit (see p. 92), to complete your drive.

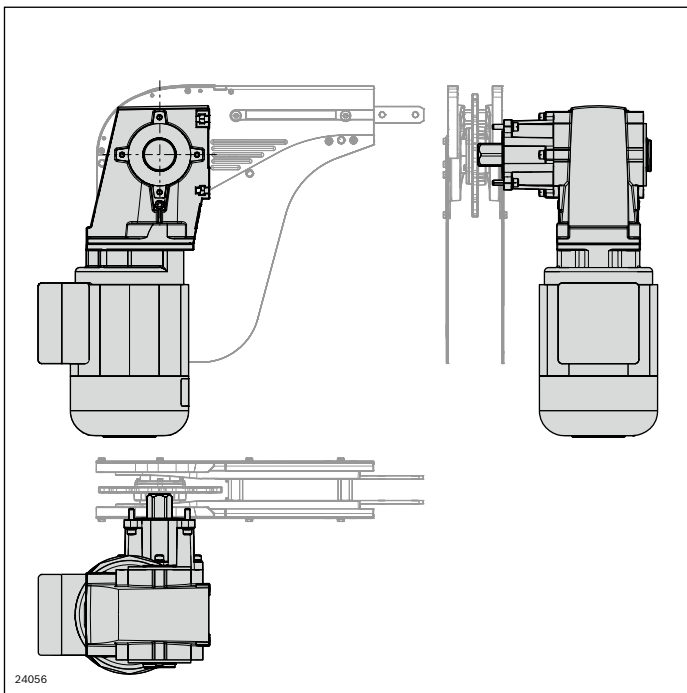

Drive kit VFplus	No.
	3 842 998 291

See page 92

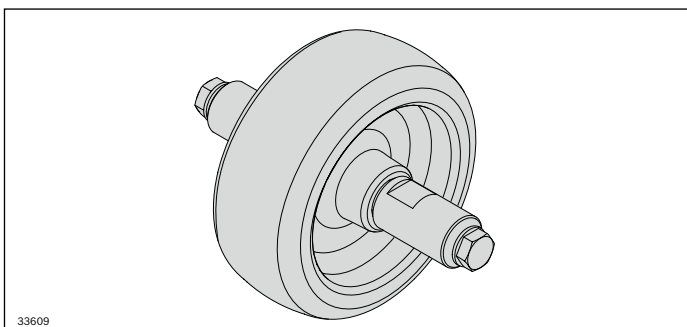

Chain sprocket	No.
VFplus 65	3 842 553 047
VFplus 90	3 842 553 048
VFplus 120	3 842 553 049
VFplus 160	3 842 553 057
VFplus 240	3 842 553 058
VFplus 320	3 842 553 059

## Basic unit AL

### Connection drive

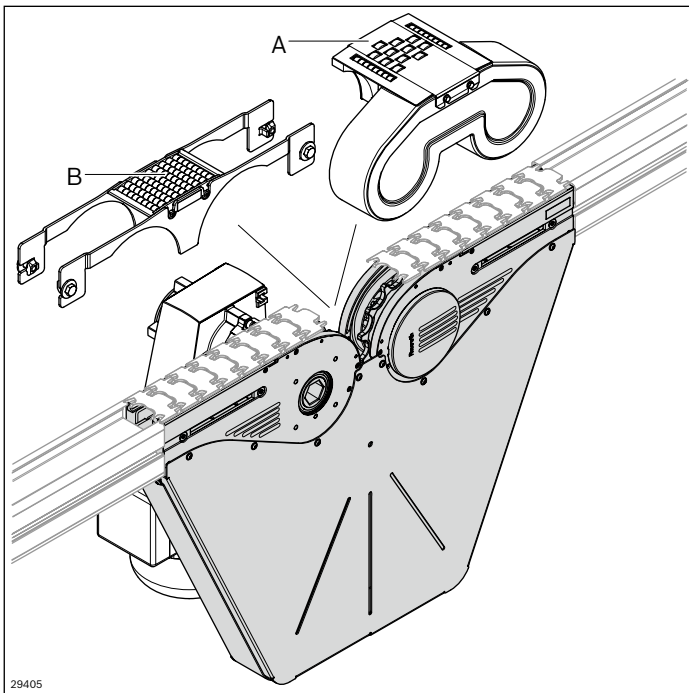

- ▶ Reduced noise emission due to slide rails guided in the connection drive
- ▶ Installation of the drive kit possible on the right/left (motor, coupling, flange)
- ▶ Drive of a parallel conveyor section or bridge using a hexagonal hollow shaft integrated as standard
- ▶ Stainless steel ball bearings, with sealing on both sides and FDA-compliant lubrication
- ▶ Side elements with slot to attach holders for lateral guides, or similar

#### Required accessories:

- Drive kit, see page 92
- Active bridge **(A)** or passive bridge **(B)**, see p. 102
- Slide rail: Length calculation, see page 278

Scope of delivery: Incl. fastening material

Condition on delivery: Fully assembled

The connection drive is used for driving the conveyor chain in circuit systems with a top-running chain. Supplementing the basic unit connection drive with the drive kit quickly turns it into a complete connection drive with a variable mounting position. For transferring the conveyed material, an active **(A)** or passive bridge **(B)** must be added. The active bridge **(A)** is driven by a transmission from the connection drive

- Size: 65, 90
- Suitable chain types: flat conveyor chain, static friction chain
- Permissible chain tensile force:  $F_{max} = 1250 \text{ N}$
- Section length:  $L \leq 30 \text{ m}$
- Conveying speed:  $v_N = 2 \dots 25 \text{ m/min}$ , other speeds available on request
- Chain bag to compensate for chain elongation during service life
- Recommendation: No accumulation operation up to 1500 mm after the connection drive
- Can only be used with a closed profile, for safety reasons
- Reversible operation not permitted
- Not permitted for wet operation or rough ambient conditions

#### Material:

- Housing: Die-cast aluminum, powder-coated
- Chain wheel: PA
- Chain guide: PA
- Connector: steel; galvanized
- Hexagonal shaft  
up to size 160: PA  
from size 160: Stainless steel + PA
- Ball bearings: Stainless steel/ FDA
- Chain fender: steel; galvanized

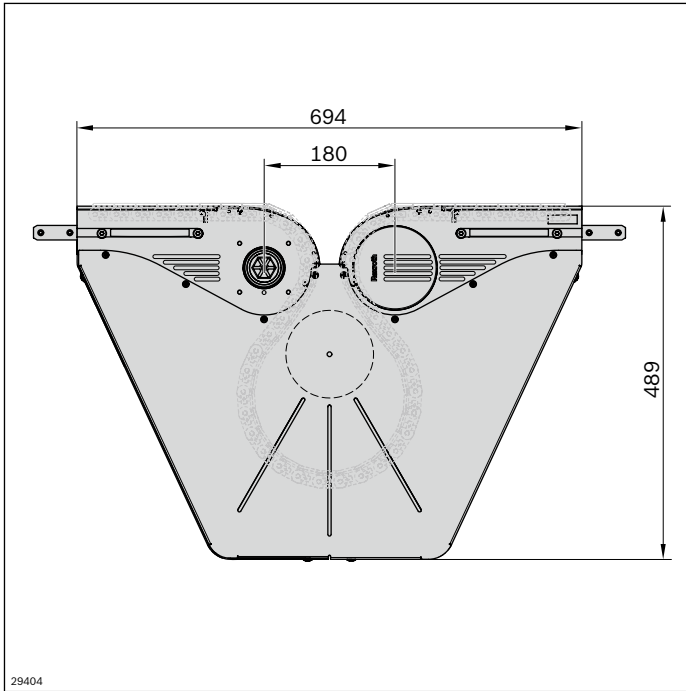

29404

3

<b>Basic unit connection drive AL</b>	<b>No.</b>
<i>VFplus 65</i>	<b>3 842 547 712</b>
<i>VFplus 90</i>	<b>3 842 547 713</b>

<b>Drive kit <i>VFplus</i></b>	<b>No.</b>
	<b>3 842 998 291</b>

See page 92

<b>Connection kit active bridge</b>	<b>No.</b>
<i>VFplus 65</i>	<b>3 842 555 820</b>
<i>VFplus 90</i>	<b>3 842 555 821</b>

See page 102

<b>Passive bridge connection kit</b>	<b>No.</b>
<i>VFplus 65</i>	<b>3 842 549 015</b>
<i>VFplus 90</i>	<b>3 842 549 016</b>

See page 102



## Basic unit with center drive

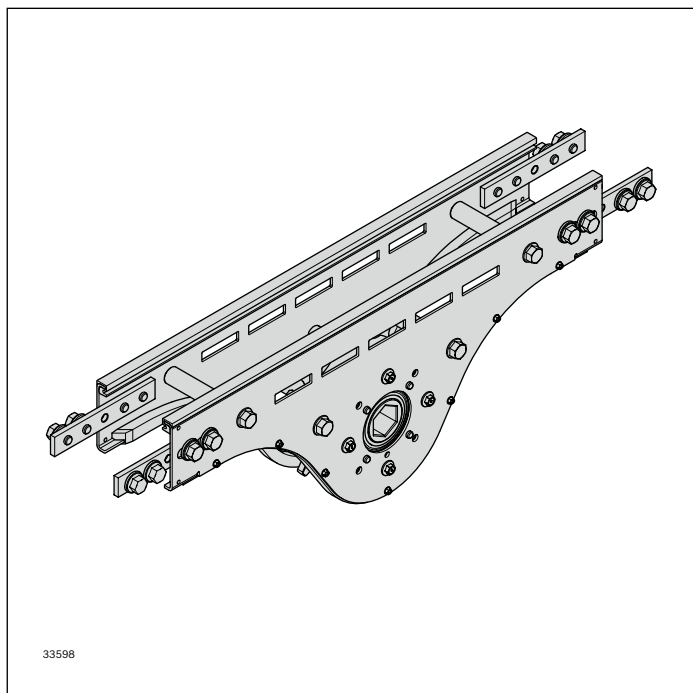
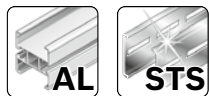

The center drive basic unit is used if the available space is limited at the ends of the sections.

It is quickly turned into a center drive with variable motor mounting position by adding the drive kit

- Size: 65-120
- Chain return on the underside of the profile
- Conveying speed:  $v_N = 2 \dots 60$  m/min, other speeds available on request
- Permissible chain tensile force:  $F_{max} = 600$  N
- Max. conveying length: 7 m
- Because no length compensation (chain bag) is present, the chain length must be checked regularly and shortened if necessary
- Recommendation: no accumulation operation until 1000 mm after the return unit
- An assembly module is required for assembling the chain

- ▶ Reduced noise emission due to slide rails guided in the center drive
- ▶ Installation of the drive kit possible on the right/left (motor, coupling, flange)
- ▶ Drive of a parallel conveyor section using a hexagonal hollow shaft integrated as standard

- ▶ Stainless steel ball bearings, with sealing on both sides and FDA-compliant lubrication
- ▶ Side elements with slot for attaching holders for lateral guides, or similar

### Required accessories:

- Drive kit, see page 85
- Slide rail, see page 56
- Motor leg sets/ESD motor leg sets, see page 115/189
- Assembly module, see page 61

### Optional accessories:

- Synchronous drive connection kit, see page 104
- Frequency converter, see page 96
- Transmission kit, see page 100

### Scope of delivery:

- Incl. fastening material
- For AL systems: Adapter VFplus AL-ST5

### Material:

- Housing: Stainless steel
- Chain wheel: PA
- Chain guide: PA
- Connector: Stainless steel
- Hexagonal shaft, PA
- Ball bearings: Stainless steel/ FDA

### Condition on delivery:

Assembled, (profile connector enclosed)

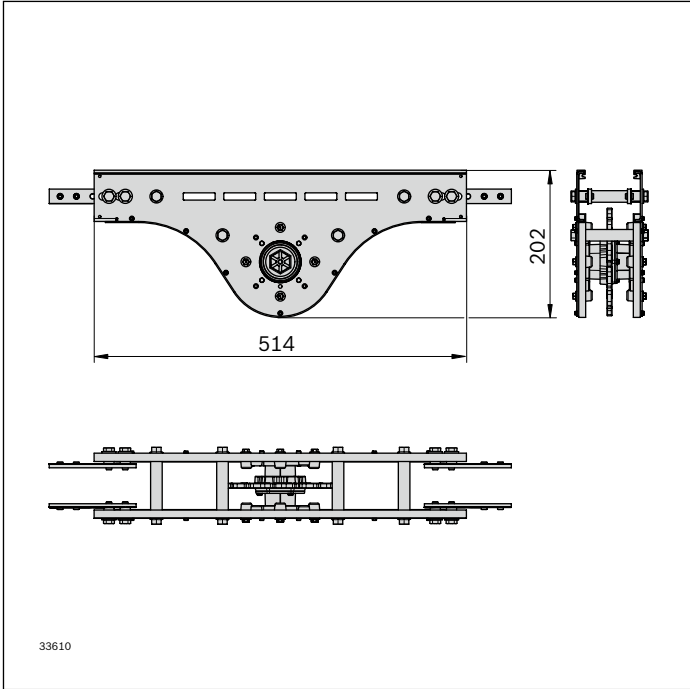

Basic unit with center drive	No.
VFplus 65	3 842 552 940
VFplus 90	3 842 552 941
VFplus 120	3 842 552 942

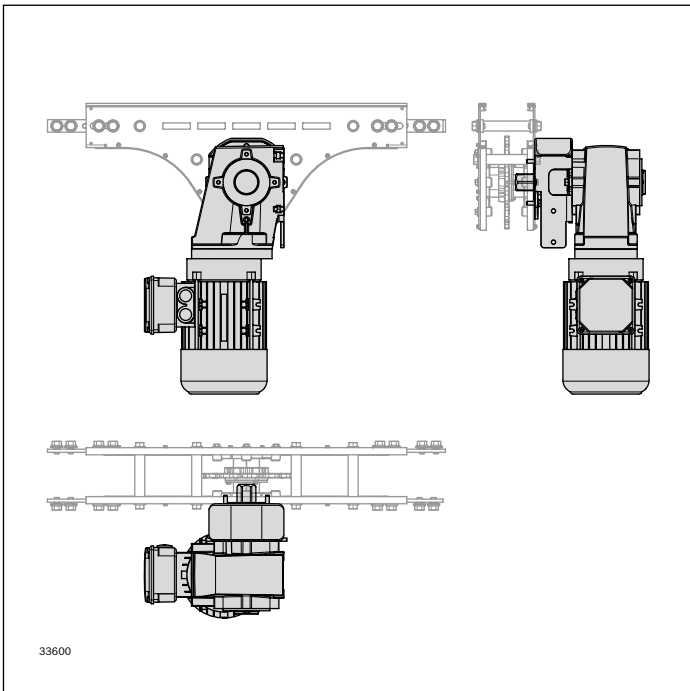

Drive kit VFplus	No.
VFplus 65	3 842 998 291

See page 92

**Note:** The selection of the parameter SP = STS is imperative. Even if an aluminum track is used because centering is not possible on an AL flange.

## Return unit AL

### Closed head drive AL

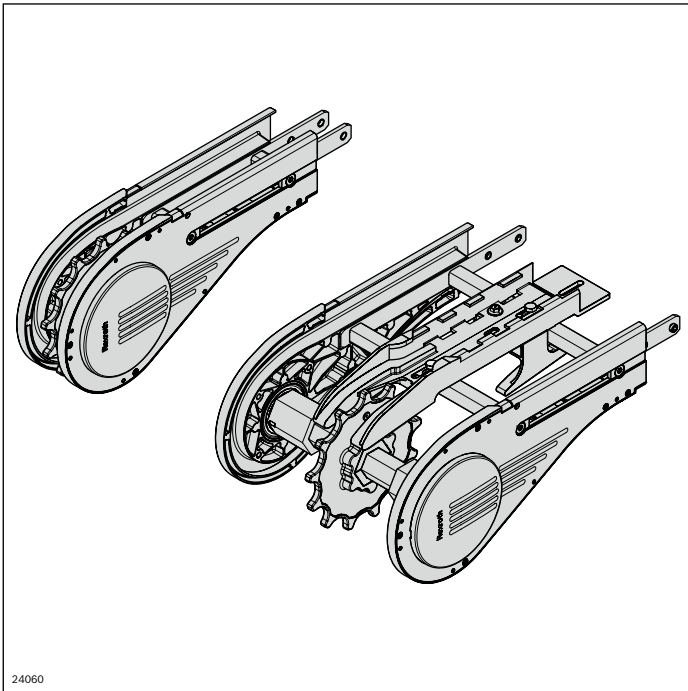

- ▶ Reduced noise emission due to slide rails guided in the return unit
- ▶ Installation of the drive kit possible on the right/left (motor, coupling, flange)
- ▶ Drive of a parallel conveyor section or bridge using a hexagonal hollow shaft integrated as standard

#### Required accessories:

- Slide rail: Length calculation, see page 278

#### For use as a drive:

- Assembly module, see page 61
- Drive kit, see page 92
- Motor leg sets, see page 111/115

#### Scope of delivery:

Incl. fastening material

#### Condition on delivery:

Fully assembled

Thanks to the innovative drive concept, the return unit can be operated simply by itself or supplemented with a drive kit to be operated as a head drive without chain bag. The section length is limited to a maximum of 7 m.

- Size: all track widths
- Suitable chain types: all
- Permissible chain tensile force  
Return unit function:  $F_{max} = 1250 \text{ N}$   
Head drive without chain bag function:  $F_{max} = 600 \text{ N}$   
With shortened maintenance interval, due to chain elongation
- Section length for return unit function:  $L \leq 30 \text{ m}$   
Section length for function as drive:  $L \leq 7 \text{ m}$
- Conveying speed:  $v_N = 2 \dots 60 \text{ m/min}$ , other speeds available on request
- Use as a drive for wedge conveyors, when combined with a drive kit
- Not suitable for reversible operation

- ▶ Stainless steel ball bearings, with sealing on both sides and FDA-compliant lubrication
- ▶ Implementation of parallel sections with gap dimension down to zero
- ▶ Side elements with slot to attach holders for lateral guides, or similar

#### Optional accessories:

Transmission kit, see page 100

#### Material:

- Housing: Die-cast aluminum, powder-coated
- Chain wheel: PA
- Chain guide: PA
- Connector: steel; galvanized
- Hexagonal shaft  
up to size 160: PA  
from size 160: Stainless steel + PA
- Ball bearings: Stainless steel/ FDA

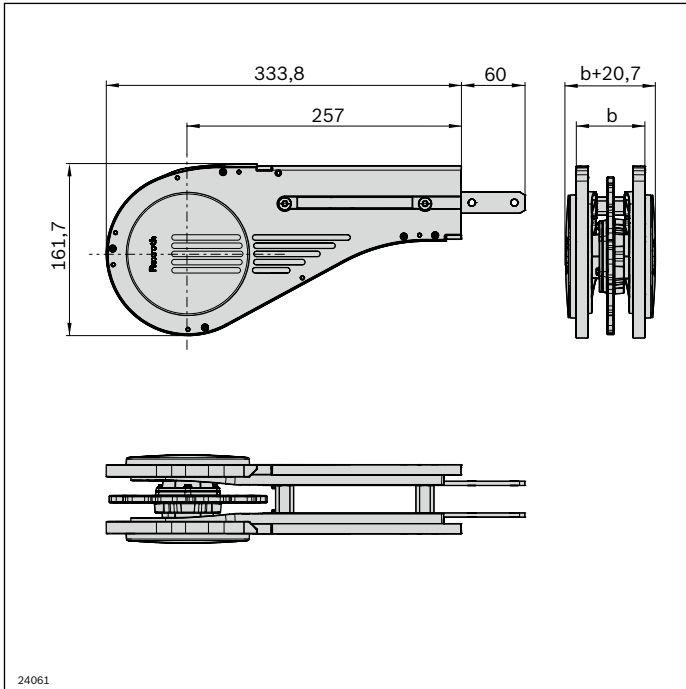

<b>Return unit AL</b>	<b>No.</b>
VFplus 65	<b>3 842 547 516</b>
VFplus 90	<b>3 842 547 517</b>
VFplus 120	<b>3 842 547 518</b>
VFplus 160	<b>3 842 547 519</b>
VFplus 240	<b>3 842 547 520</b>
VFplus 320	<b>3 842 547 521</b>

## 90° return unit

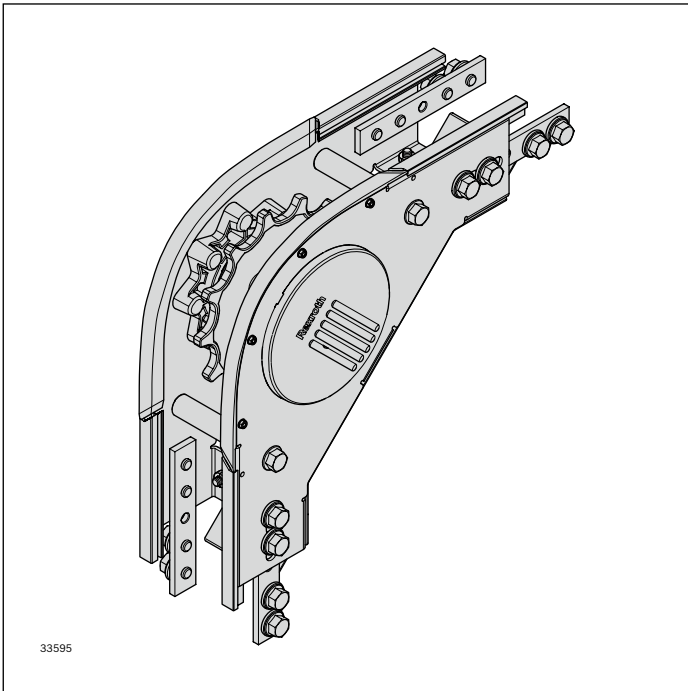

For building alpine conveyors with chain running only on the upper side.

- Only for use with:
  - Connection drive (AL and STS)
  - Curve wheel drive AL (drive kit parameter AC = 1)
- Size: 65, 90
- Section length:  $L_{max} = 30$  m
- Alpine conveyor for curve wheel drive or connection drive

**Note:** When using conveyor systems without a returning chain, a cover must be mounted by the customer to ensure personal safety.

Advantage over alpine conveyor with head drive:

- ▶ shorter chain return, so the required tensile force of the conveyor chain is lower and therefore the possible volume of the alpine conveyor is larger.

- ▶ No longer necessary to mount the slide rails required for the chain return on the bottom side of the profile
- ▶ The required conveyor chain is shorter

Scope of delivery:

- Incl. fastening material
- For AL systems: AL-STS adapter

Material:

- Housing: Stainless steel
- Chain wheel: PA
- Chain guide: PA
- Connector: Stainless steel
- Hexagonal shaft, PA
- Ball bearings: Stainless steel/ FDA

Condition on delivery:

Fully assembled

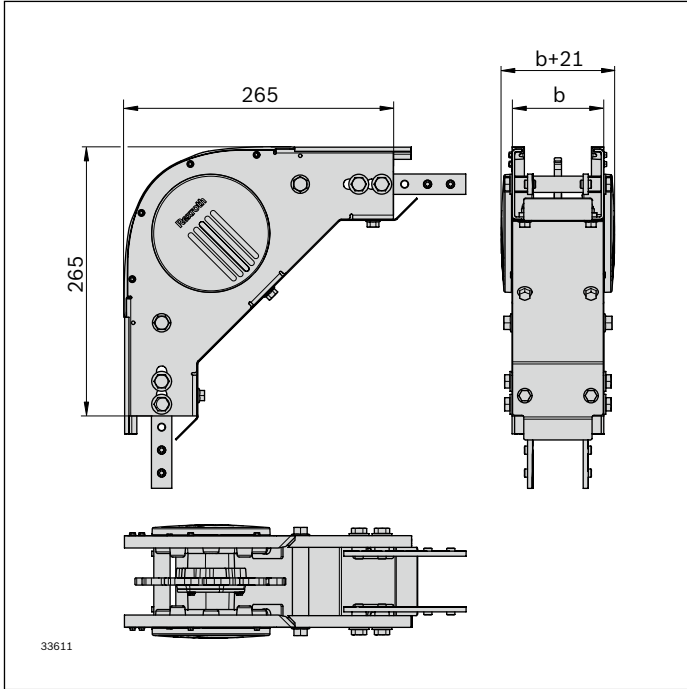

90° return unit		No.
VFplus 65	1	<b>3 842 552 984</b>
VFplus 90	1	<b>3 842 552 985</b>

3

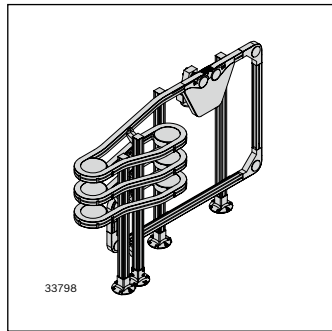
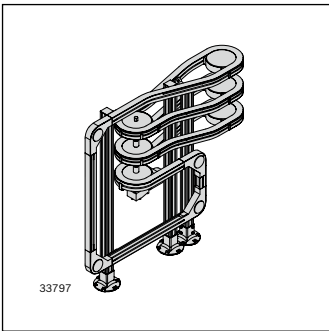



## Basic unit

### Curve wheel drive AL

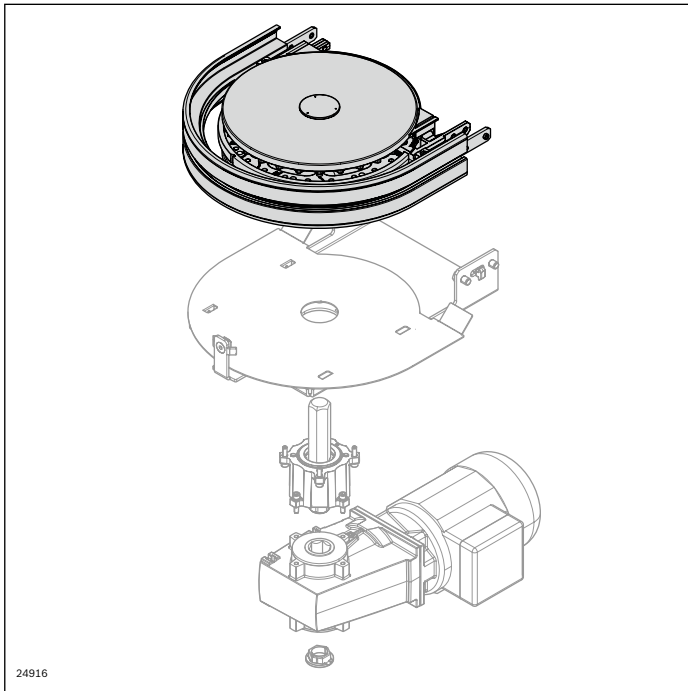

The curve wheel drive is used for driving the conveyor chain in circuit systems with a top-running chain. Combining the basic unit curve wheel 180° AL with the appropriate drive kit quickly turns it into a curve wheel drive.

- Size: 65 and 90
- Suitable chain types: all
- Permissible chain tensile force:  $F_{\max} = 400$  N per level  
Section length for closed circuits  $L \leq 10$  m
- Permissible torque:  $M_{\max} = 60$  Nm  
When combining several curve wheel basic units, the motor torque must be distributed across the individual levels
- Conveying speed:  $v_N = 4 \dots 21$  m/min  
For drives with frequency converters (FU), the speed must be limited to a maximum of 21 m/min using control technology
- Recommendation: no accumulation operation until 1000 mm after the curve wheel drive
- Can only be used with a closed profile

- ▶ Driving several superimposed basic curve wheel units is easily implemented via the integrated hexagonal hollow shafts
- ▶ Stainless steel ball bearings, with sealing on both sides and FDA-compliant lubrication
- ▶ Side elements with slot to attach holders for lateral guides, or similar

#### Required accessories:

- Curve wheel drive kit, see page 94
- Assembly module, see page 61
- Slide rail: Length calculation, see page 278
- Leg set, see page 113

#### Optional accessories:

Alpine conveyor connection kit, see page 106

#### Scope of delivery:

Incl. fastening material

#### Condition on delivery:

Not assembled

#### Material:

- Housing: Aluminum, die-cast
- Chain wheel: PA; white
- Ball bearings: Stainless steel/ FDA

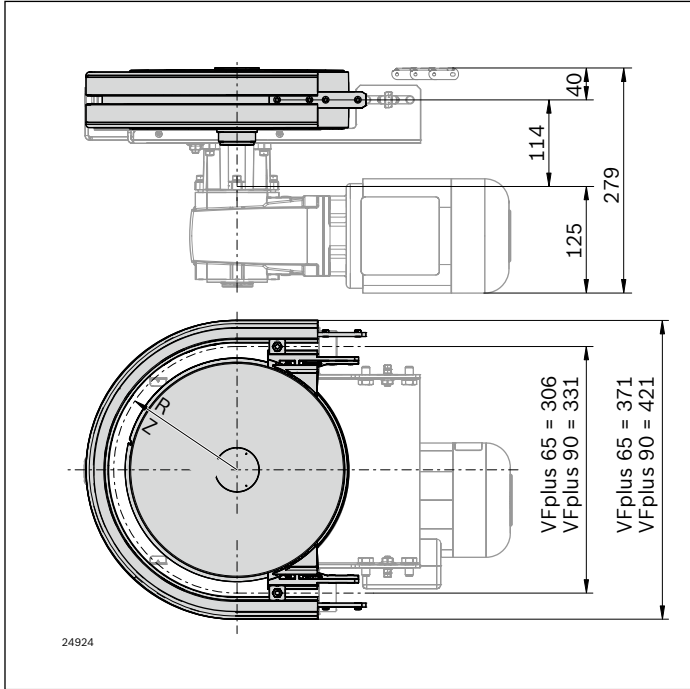

Basic unit curve wheel AL	$\alpha$ (°)	No.
VFplus 65	180	<b>3 842 547 380</b>
VFplus 90	180	<b>3 842 547 381</b>

3

	R (mm)	Z <sup>1)</sup>
VFplus 65	153.0	28
VFplus 90	165.5	30

<sup>1)</sup> Number of teeth

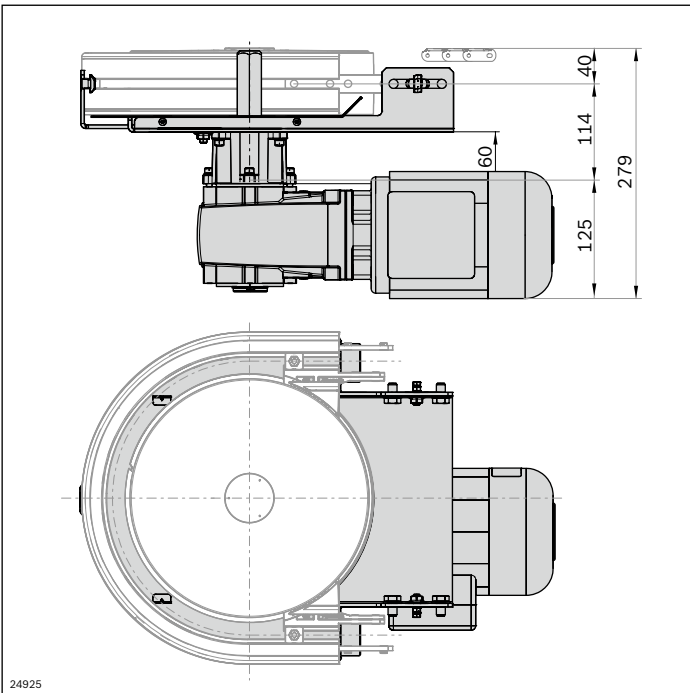

Drive kit curve wheel VFplus AL	No.
	<b>3 842 998 742</b>

See also page 94

## Drive kit

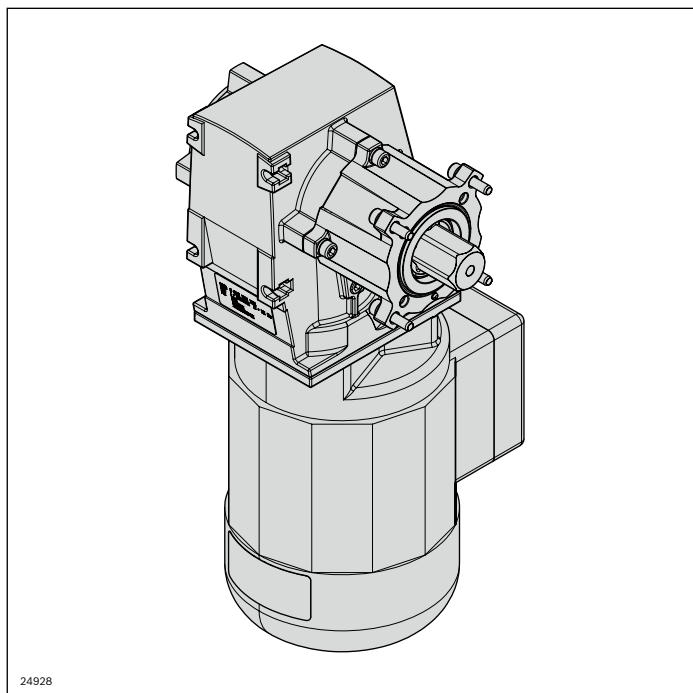

- The adjustable ball catch coupling is protected and integrated in the flange to save space

The drive kit is designed to operate the basic head drive/connection drive units and the return unit (closed drive). It contains a flange for attaching the motor to the basic unit, a hexagonal shaft for transmission of force, as well as other optional equipment features.

- Versions in aluminum (SP = AL) or stainless steel (SP = STS)
- For SP=AL, with adjustable ball catch coupling (Kpg = 1) or without (Kpg = 0). The coupling does not provide personal safety. Preset to maximum chain tensile force at the factory
- With Lenze gear motor (GM = 1) or with an interface for attaching an SEW SA47 gear motor (GM = 2). An adaptation is required by the customer for attaching other gear motors (GM = 0), see page 93
- Fixed or adjustable speed ( $v_N$ ). For an adjustable speed, gear motors must be retrofitted with an FU (frequency converter), see page 96
- Different voltages and supply frequencies (U/f)
- Connections are made using terminal boxes (AT = K) or plugs (AT = S)
- GM = 1 without surface and corrosion protection

Optional accessories:

Frequency converter, see page 96

Scope of delivery:

- Incl. fastening material
- Incl. flange, shaft and gear motor (GM = 1)

Condition on delivery:

Assembly kit

Material:

- Flange, motor: Die-cast aluminum
- Shaft: Stainless steel/PA
- Ball catch coupling: steel

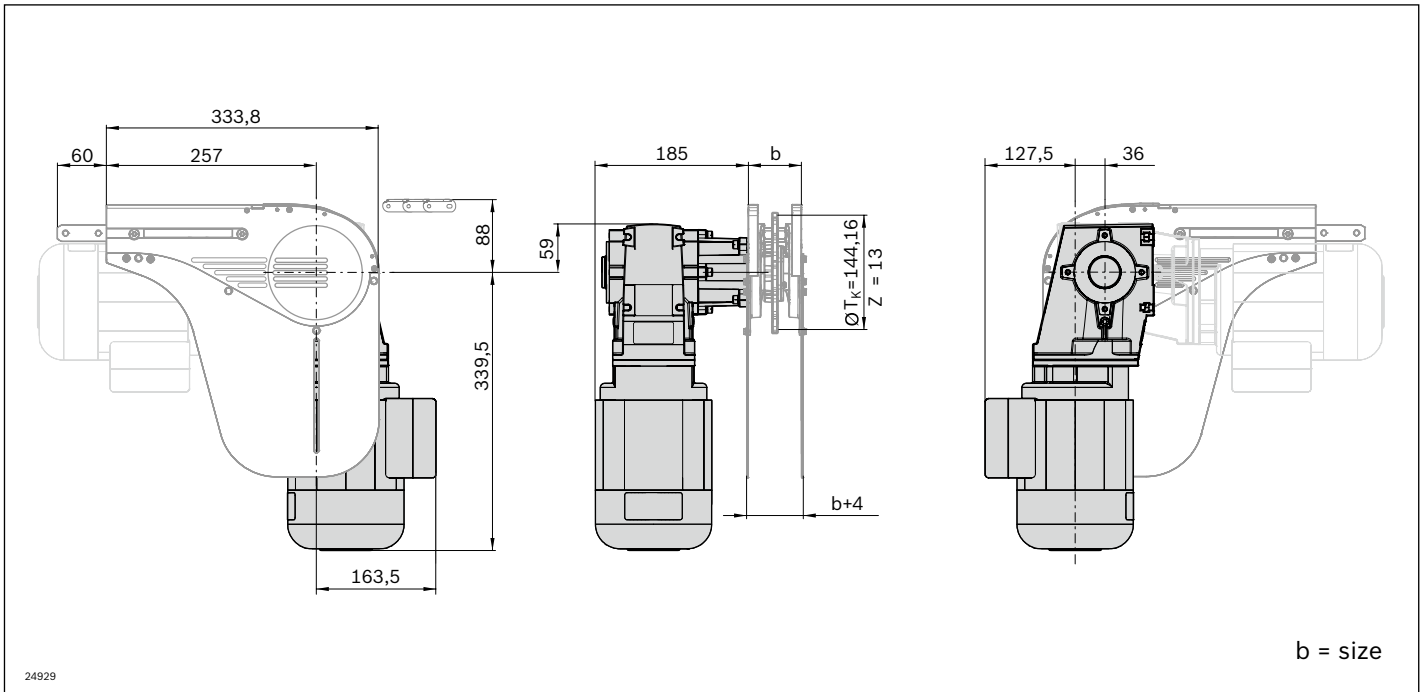

Drive kit VFplus	SP	GM	Kpg	$v_N$ (m/min)	U/f (V/Hz) See page 281	AT	No.
	AL; STS*	0; 1; 2	0; 1	5, 10, 13, 16, 21, 27, 33, 40, 50		K; S	<b>3 842 998 291</b> SP = ... GM = ... Kpg = ... $v_N$ = ... U/f = ... AT = ...

\* STS version see page 156

AL GM = 0

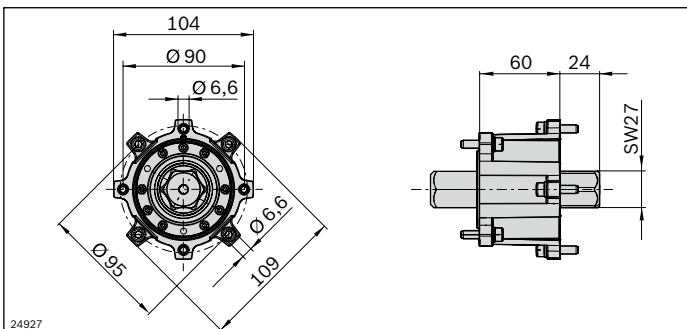

AL GM = 2

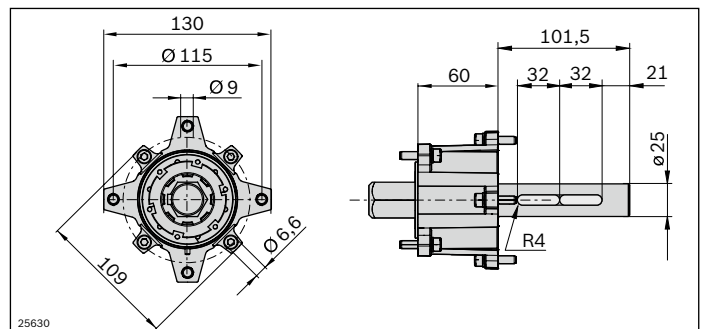

## Drive kit curve wheel AL

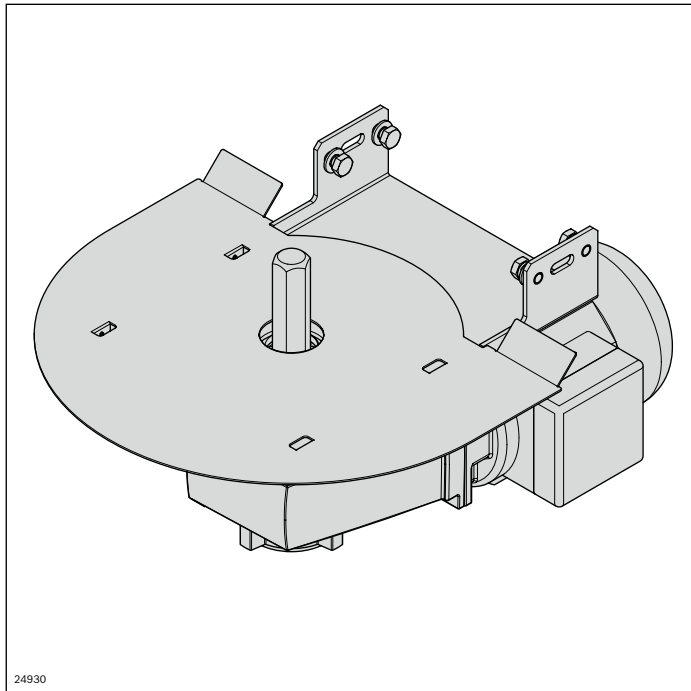

- ▶ The transmission of force of several superimposed curve wheels is possible. The motor torque then has to be distributed across all curve wheel levels.
- ▶ The adjustable ball catch coupling is protected and integrated in the flange to save space

Required accessories:

Motor leg sets, see page 115

Scope of delivery:

- Incl. fastening material
- Incl. fender (contact protection from below)
- Incl. flange, shaft and gear motor (GM = 1)

Material:

- Flange: Aluminum, die-cast
- Shaft: STS
- Connecting sheet, cover sheet: Steel; galvanized
- Ball catch coupling: Steel

The 180° curve wheel (aluminum version) is quickly transformed into a curve wheel drive by using a drive kit. It contains a flange for attaching the motor to the curve wheel, a hexagonal shaft for transmission of force, as well as other optional equipment features.

- To construct a circuit with curve wheel (AC = 0) or an alpine conveyor (AC = 1)
- With preset ball catch coupling (Kpg = 1) for limiting torque or for the alpine conveyor drive kit (AC = 1), also without (Kpg = 0). The coupling does not provide personal safety.
- With Lenze gear motor (GM = 1) or with an interface for attaching an SEW SA47 gear motor (GM = 2). An adaptation is required by the customer for attaching other gear motors (GM = 0), see page 95
- Fixed or adjustable speed ( $v_N$ ). For an adjustable speed, gear motors must be retrofitted with an FU (frequency converter), see page 96
- Different voltages and supply frequencies (U/f)
- Connections are made using terminal boxes (AT = K) or plugs (AT = S)
- GM = 1 without surface and corrosion protection
- Conveying speed:  $v_N = 4 \dots 21$  m/min. For drives with frequency converters (FU), the speed must be limited to a maximum of 21 m/min using control technology.

Condition on delivery:

Assembly kit

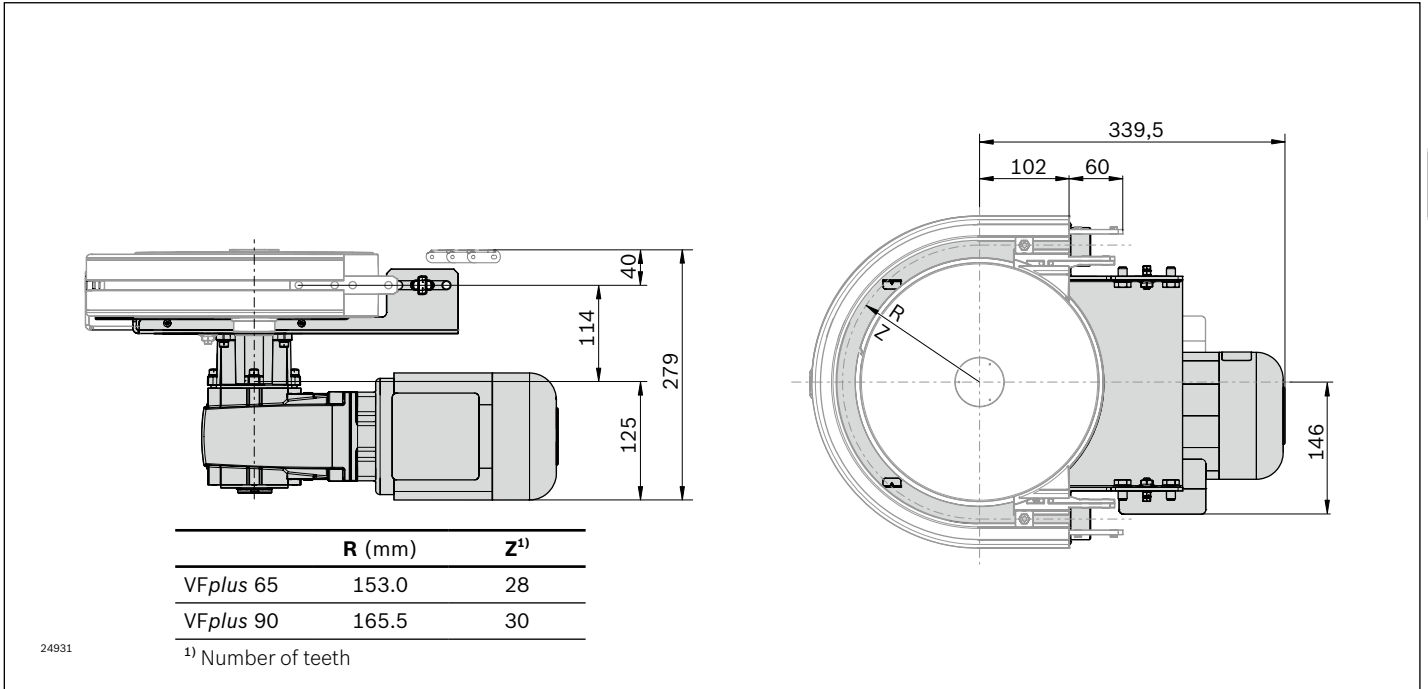

Drive kit curve wheel AL	GM	AC	b (mm)	Kpg	v <sub>N</sub> (m/min)	U/f (V/Hz) See page 281	AT	No.
	0; 1; 2	0; 1	65; 90	0; 1	5, 10, 13, 21		K; S	<b>3 842 998 742</b> GM = ... AC = ... b = ... Kpg = ... v <sub>N</sub> = ... U/f = ... AT = ...

AL GM = 0

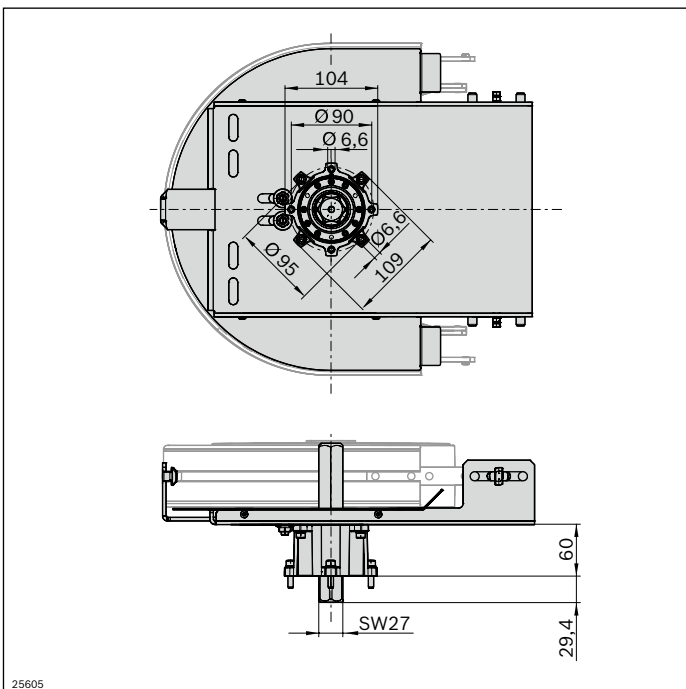

25605

AL GM = 2

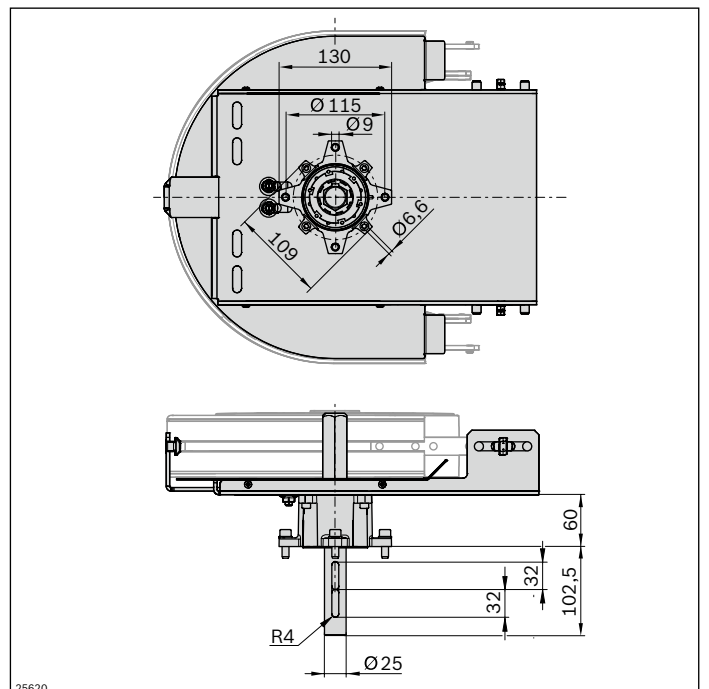

25620



## Frequency converter motec 8400

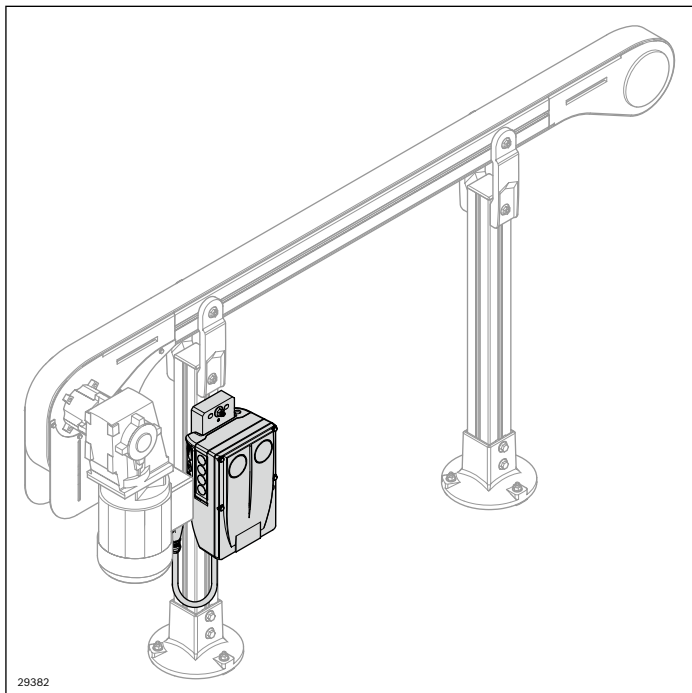

In order to operate a gear motor with adjustable speed, the motor needs to be retrofitted with a frequency converter (FU). The frequency converter has a modular design so that it can be easily mounted on a leg set and connected to the motor by cable.

- Connection power: 0.55 kW (connection voltage: 400 V  $\pm$  10% ... 460 V/480 V  $\pm$  10%)
- Speed ( $v_N$ ) depending on the base speed of the gear motor used

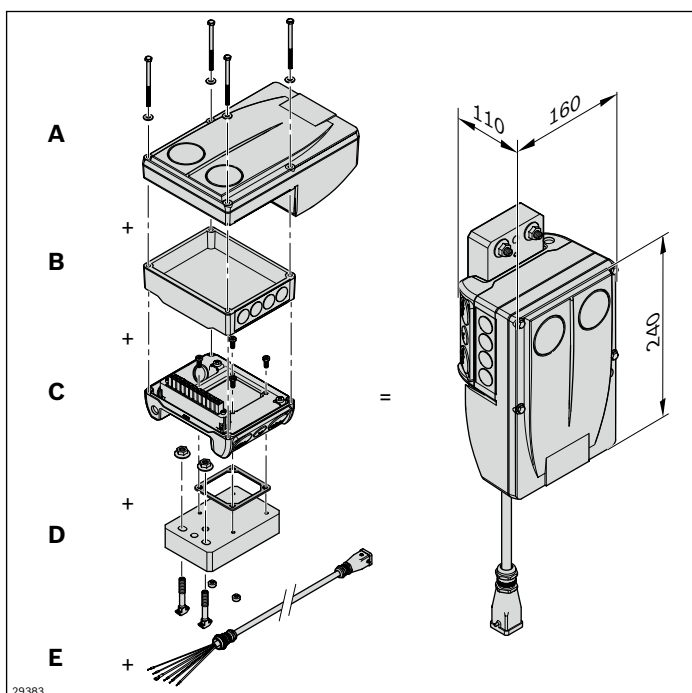

### Complete frequency converter consisting of the modules

- Frequency converter power element (A)
- Communication module (B)
- Connection unit (C)
- Attachment kit (D)
- Optional: Connection cable (E) for the plug-in connection to the gear motor (AT = S)

The individual modules can be ordered separately and are easy to connect with the supplied screws. For the internal and external voltage supply, the modules must be wired by the user (see terminal box assignment, page 285).

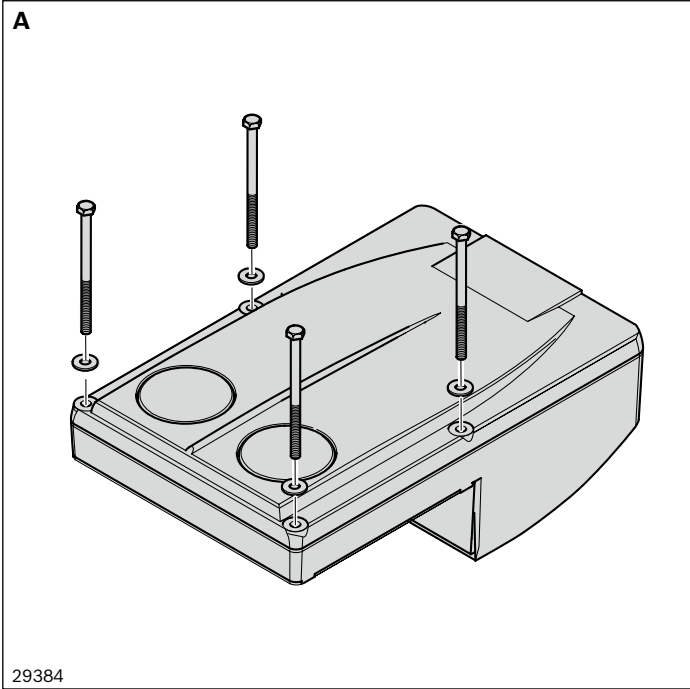

29384

**Frequency converter (A)**

Power unit: 0.55 kW

(400 V ± 10% ... 460 V/480 V ± 10%)

- Easy commissioning via hand-held terminal
- Easy to replace memory module
- Large LED as status display

Frequency converter	No.
Power element 0.55 kW	<b>3 842 553 447</b>

The speed range of the frequency converter \*) is based on the base speed of the motor:

Base speed of motor (m/min) at 50 Hz	Min <sup>1)</sup> (m/min)	Max <sup>2)</sup> (m/min)
5 <sup>3)</sup>	2	6
10 <sup>3)</sup>	4	12
13	5	15
16	6	19
21	7	25
27	9	32
33	11	39
40	13	48
50	16	60

\*) By accepting a resulting loss of power, a higher bandwidth can be covered (see page 285)

<sup>1)</sup> Min corresponds to approx. 16 Hz supply frequency

<sup>2)</sup> Max corresponds to approx. 60 Hz supply frequency

<sup>3)</sup> At 460 V/60 Hz max (m/min) 20% higher

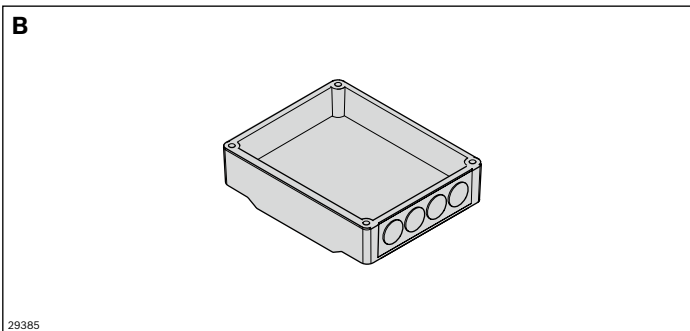

29385

**Communication module (B)**

- Used to control the frequency converter
- Cable connection options

Depending on their function, the individual communication modules are provided with the corresponding connections.

Communication module	No.
Standard I/O	<b>3 842 553 449</b>
AS-i	<b>3 842 553 453</b>
CANopen	<b>3 842 553 454</b>
EtherNet/IP	<b>3 842 553 451</b>
EtherCAT	<b>3 842 553 459</b>
PROFIBUS	<b>3 842 553 452</b>
PROFINET	<b>3 842 553 450</b>

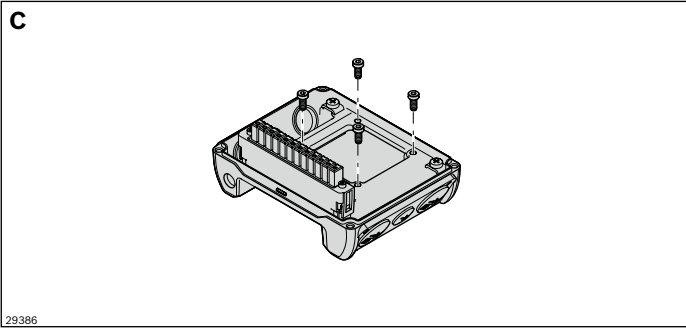

**Connection unit (C)**

- Power grid connection options

Connection unit	No.
	3 842 553 445

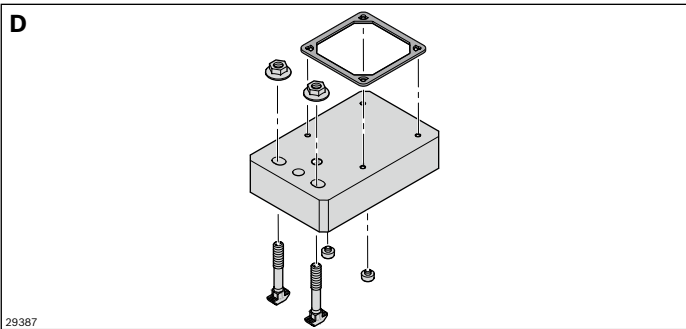

**Attachment kit (D)**

- For the simple attachment of the frequency converter to the AL section support (slot/s with a 60 or 80 strut profile)

Attachment kit	No.
	3 842 553 457

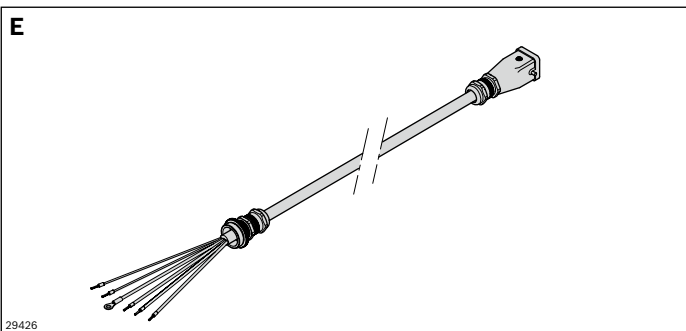

**Connection cable (E)**

- For connecting the gear motor with the frequency converter (length: 1 m)
- For the drive kit AT = S (direct wiring with AT = K)

Connection cable	No.
	3 842 553 512

# Manual control unit

## Switch/potentiometer unit

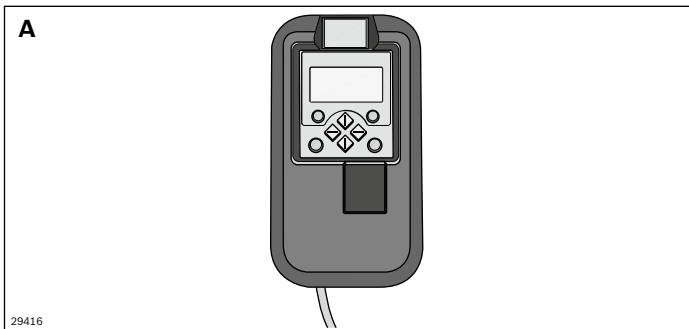

### Manual control unit

The manual control unit is required for the parameterization of drives with frequency converters.

In addition, you can:

- Control (e.g. block and release)
- Display operating data
- Steplessly regulate the transport speed
- Transfer parameter sets to other basic devices

Manual control unit	No.
	3 842 552 821

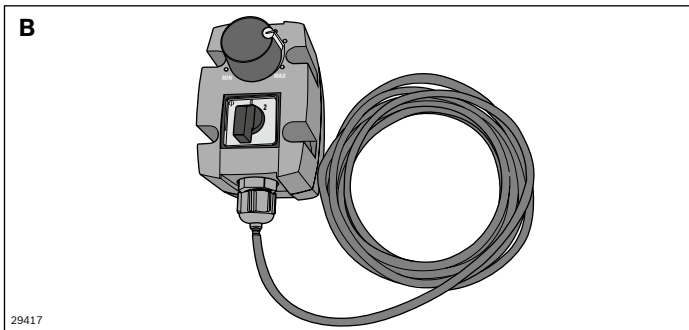

### Switch/potentiometer unit

The switch/potentiometer unit is used to fine tune the transport speed within a range that has been preset with the manual control unit. The switch/potentiometer unit is connected to the frequency converter by a cable. The drive can be started or stopped with the rotary switch.

**Note:** It is imperative that the direction in which the chain conveyor is running is checked prior to commissioning.

Switch/potentiometer unit	No.
	3 842 553 184

Scope of delivery:

**A, B:** Incl. 2.5 m connection cable

## Transmission kit

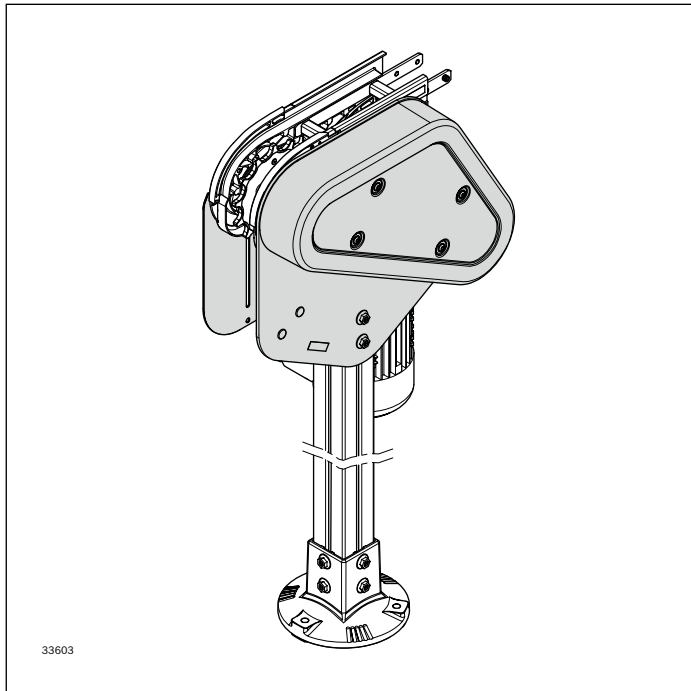

If the available space is not sufficient for mounting the drive kit directly on the basic unit, the transmission kit also enables conversion to a transmission drive at a later date. The basic units head drive, connection drive and closed head drive are quickly turned into a transmission drive with variable mounting position with the transmission kit and drive kit.

- Only for AL systems
- Size: 65, 90, 120
- Permissible chain tensile force:  $F_{\max} = 1250 \text{ N}$
- Support required
- Not suitable for wet operation/cleaning
- Mounting on STS version on request

- ▶ Installation of the drive kit possible on the right/left (motor, coupling, flange)
- ▶ Very quiet, as transmission takes place through toothed

- belt
- ▶ Stainless steel ball bearings, with sealing on both sides and FDA-compliant lubrication

Required accessories:

Leg set, see page 111

Scope of delivery:

Incl. fastening material

Condition on delivery:

Fully assembled

Material:

- Side plates: Stainless steel
- Belt: Rubber compound
- Cover: ABS
- Connecting parts: aluminum

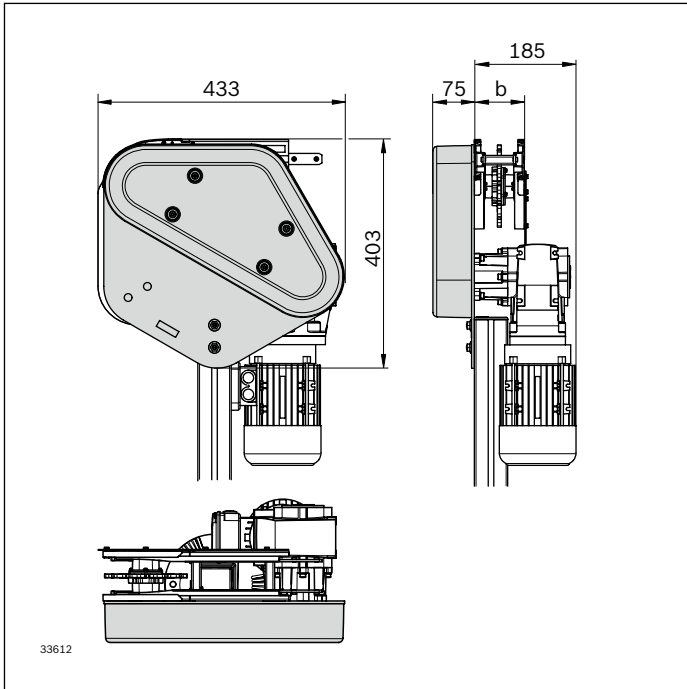

Transmission kit VFplus	No.
	3 842 552 900

b = 65, 90, 120

3

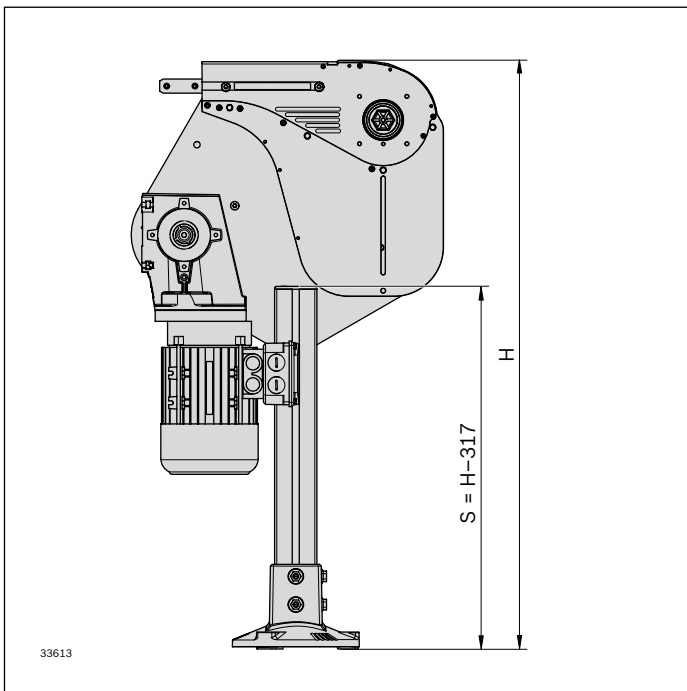

### Motor support

The leg set is mounted on the inside (below the chain).

**Note:** The motor must be mounted so that there are no collisions with the support.

H: Transport height (top edge of chain)

S: Leg set height

L: Profile length ( $L = S - 15$ )



## Connection kit active (A) bridge

## Connection kit passive (B) bridge

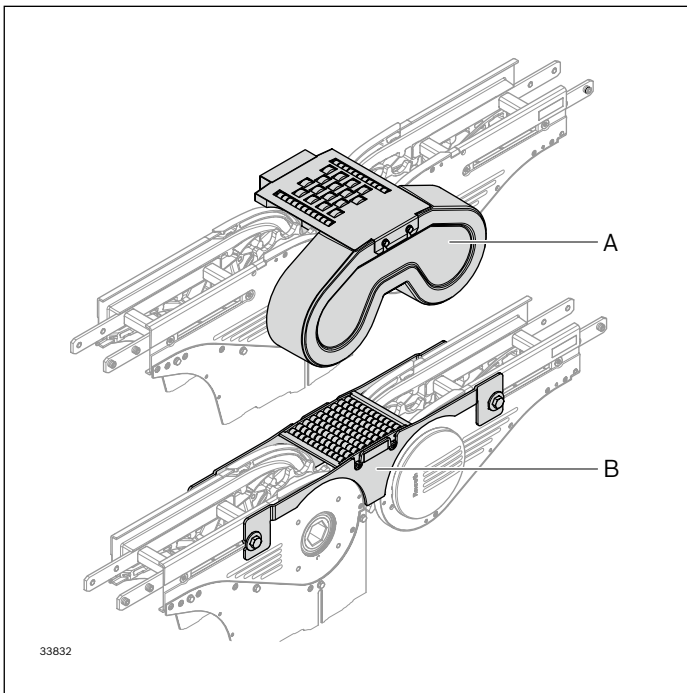

The active and passive bridges are used as a transfer unit between the basic unit and return unit or with the connection drive to bridge the flat conveyor chain.

- Size: 65-160
- Only for flat conveyor chain and static friction chain
- For dimensionally stable products with an even transport surface
- Height adjustment: approx. 3 mm
- Additional versions (e.g. machine variants) available on request

**A:** The active bridge is driven by a transmission (on the drive or return unit side).

- Suitable for conveyed materials from approx. 100 mm in length (depending on the speed, position of the center of gravity, product friction, etc.)
- Freely selectable mounting position (L/R)
- Not permitted for wet operation or rough ambient conditions

**B:** The passive bridge serves to bridge the conveyor trench.

- The conveyed goods are transferred via passive rollers
- Suitable for goods from approx. 300 mm length

- ▶ **A:** Simple transmission of the drive force using hexagonal hollow shafts integrated into the basic unit or return unit as standard
- ▶ **A+B:** Can be retrofitted into a standard configuration at any time

- ▶ **A+B:** Active and passive bridges can be used at section ends for product transfer

Scope of delivery:

- **A+ B:** Incl. fastening material
- **A:** Transmission and protective cover

Condition on delivery:

Partially assembled

Material:

- Active bridge: Stainless steel/PA/POM/ABS/PUR
- Passive bridge: Stainless steel/POM

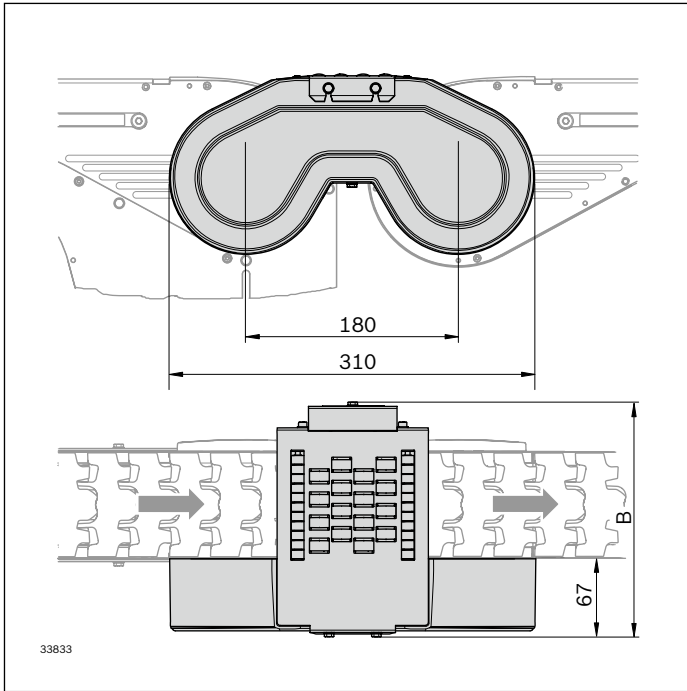

Connection kit active bridge	B	No.
VFplus 65	174	<b>3 842 555 820</b>
VFplus 90	199	<b>3 842 555 821</b>
VFplus 120	229	<b>3 842 555 822</b>
VFplus 160	269	<b>3 842 555 823</b>

3

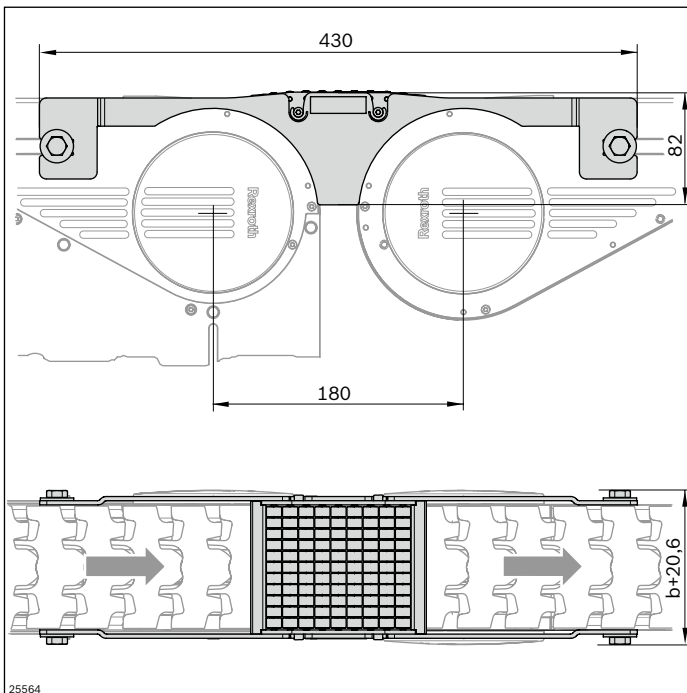

Passive bridge connection kit	No.
VFplus 65	<b>3 842 549 015</b>
VFplus 90	<b>3 842 549 016</b>
VFplus 120	<b>3 842 549 017</b>
VFplus 160	<b>3 842 549 018</b>

## Connection kit

### Synchronous drive, external motor/internal motor

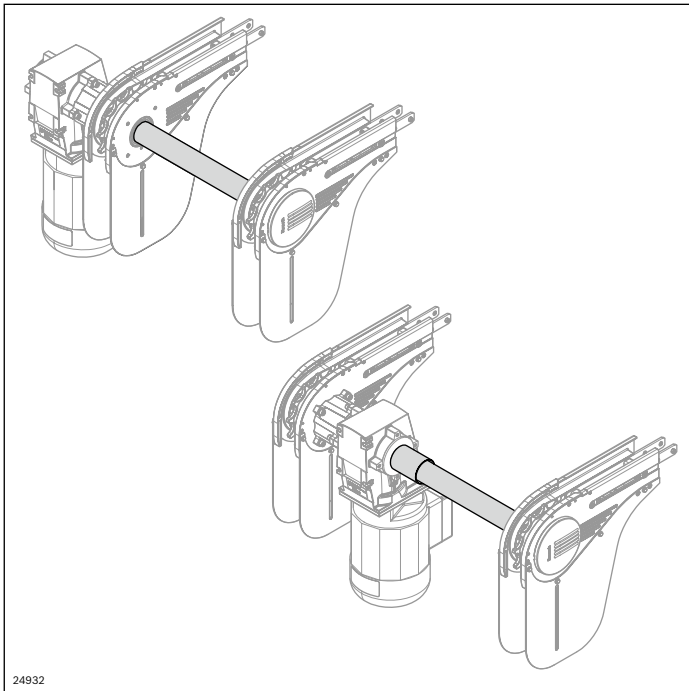

The synchronous drive connection kit is used to synchronously drive two conveyor sections with only one motor.

- External synchronous drive:
  - Motor mounting position outside the parallel sections
  - Use of AL holders (see page 111, 115), minimum distance between the sections:  
 $A_{\min AL} \geq 20 \text{ mm}$
- Internal synchronous drive:
  - Motor mounting position between the parallel sections for drive kit GM = 1 (see page 92), customer check required for other motor types

Condition on delivery:  
Not assembled

Material:

- Shaft: Stainless steel
- Coupling: PA

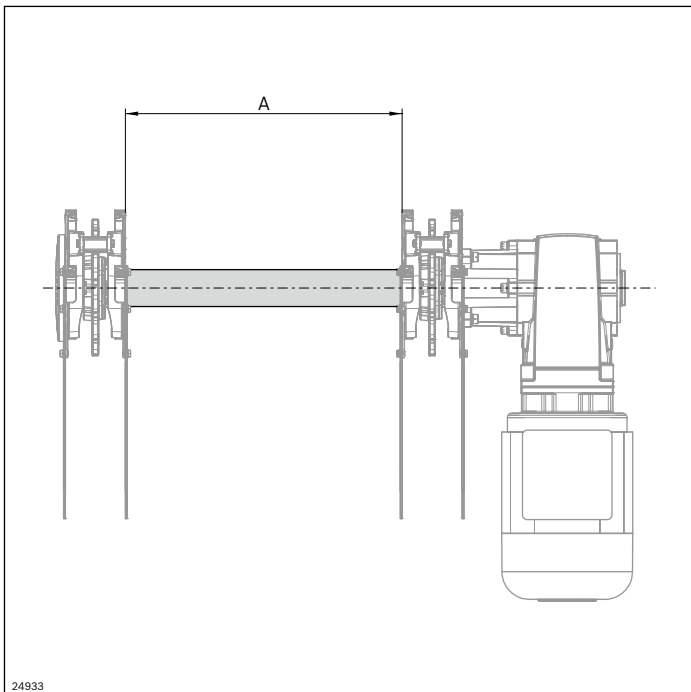

24933

Synchronous drive connection kit	A (mm)	No.
VFplus external motor	15 ... 2940	<b>3 842 998 774</b>

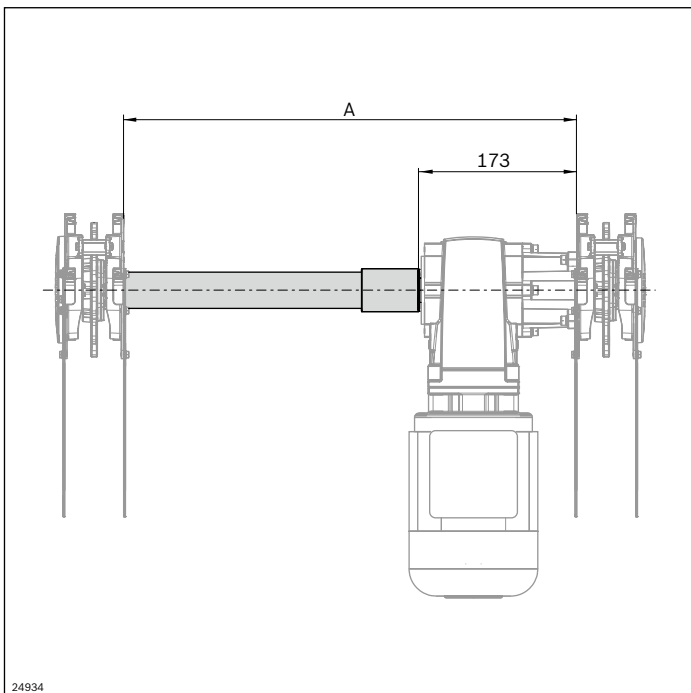

24934

Synchronous drive connection kit	A (mm)	No.
VFplus internal motor	240 ... 3160	<b>3 842 998 775</b>

## Alpine conveyor connection kit

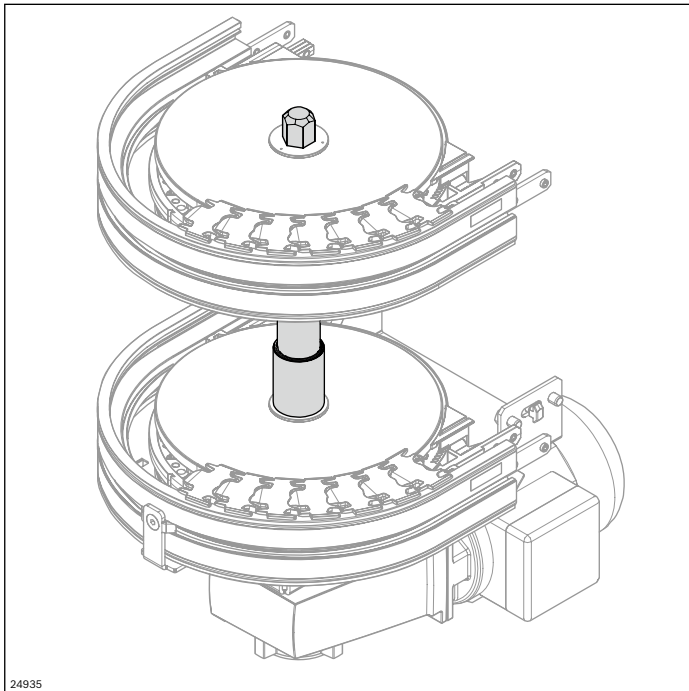

With the alpine conveyor connection kit, an alpine conveyor can be easily assembled in sizes 65 mm or 90 mm by combining multiple aluminum curve wheels.

### Material:

- Shaft: Stainless steel
- Coupling: polyamide

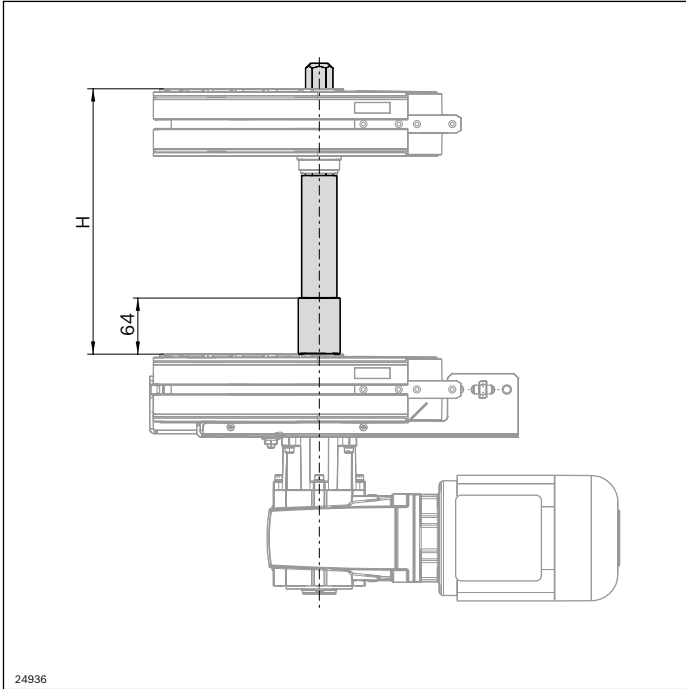

Connection kit alpine conveyor AC	H (mm)	No.
	172 ... 1000	<b>3 842 998 776</b>

3

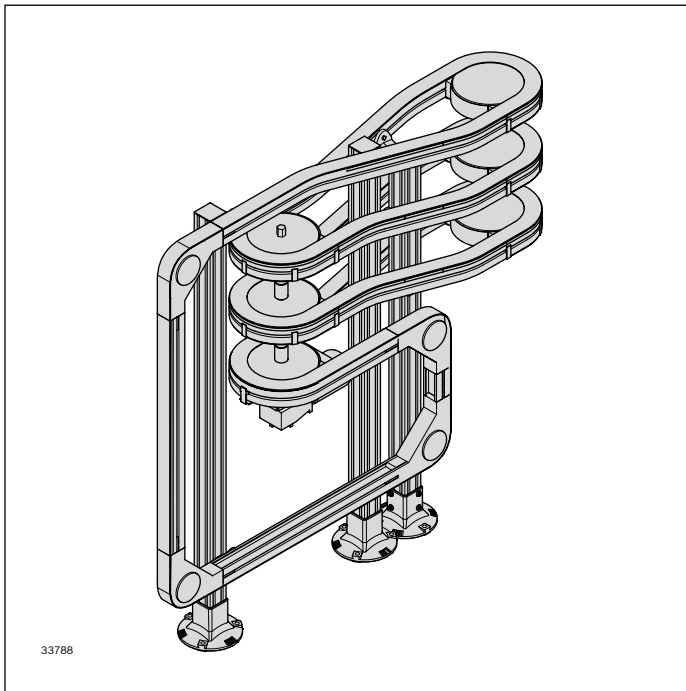





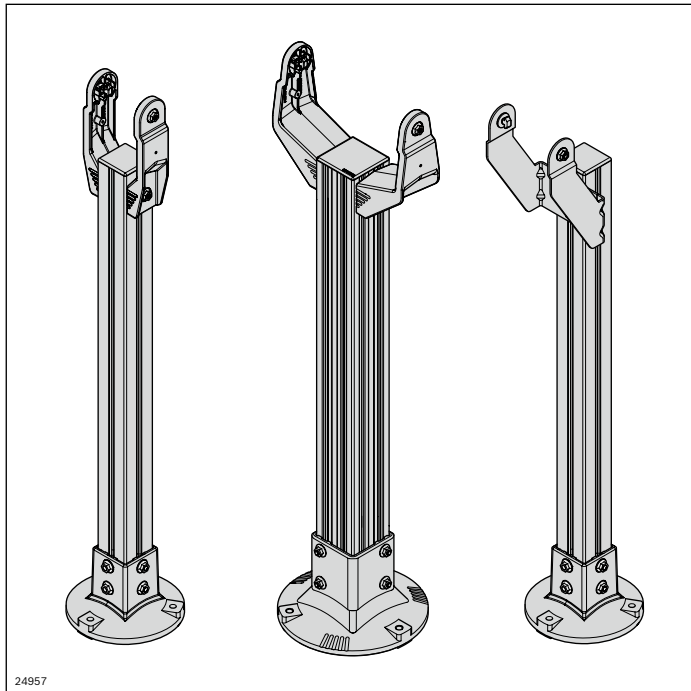

## AL leg sets



- ▶ Plug-through screws, few screwed connections
- ▶ Easy to clean thanks to ample draining surfaces
- ▶ Simple realization of ascending and descending conveyor sections thanks to a holder with centering lugs that can be broken off
- ▶ Drill guide for simple fastening of drip trays, safety devices, etc.
- ▶ Supports can also be used in conjunction with STS sections

Fast, simple leg set adjustment thanks to clever product details

	<b>AL leg set 65-120</b>	<b>110</b>
	<b>AL leg set 160-320</b>	<b>114</b>
	<b>Supporting bracket AL</b>	<b>116</b>
	<b>Supporting bracket, lateral AL</b>	<b>118</b>

## AL leg set 65-120

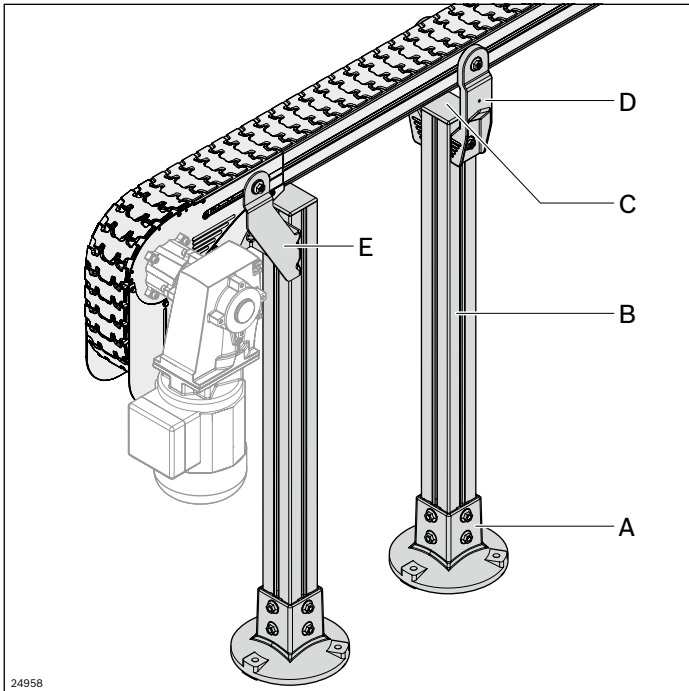

- ▶ Holder is easily centered in the slot thanks to centering lugs (**D**)
- ▶ Very simple assembly with plug-in screw connection (**D**)
- ▶ Easy-to-clean design with draining surfaces

The chain conveyor is placed on the ground by means of supports (and fastened) or even suspended from the ceiling. The suspension needs to be determined depending on the application.

The floor supports for sizes 65, 90 and 120 are constructed from the following single parts:

Foot 60x60 (**A**), strut profile 60x60 (**B**), cap (**C**), holder for attaching the section profiles (**D**) 65, 90 or 120.

A separate holder (**E**) is used to support the motors / drives.

- Depending on the speed, accumulation behavior and weight, the supports are to be fixed at a distance of approx. 2 ... 3 m
- The leg sets for the stainless steel system (see p. 168) may also be used for the aluminum system
- The holder (**E**) may only be used for AL systems
- The height adjustment range is up to 79 mm (**D**), depending on the return chain, see “Holder adjustment range” page 112
- The holder (**D**) can also be used for ascending and descending conveyor sections (up to 45°, depending on the return chain) by removing the centering lugs
- Holder (**D**) with drill guide for additional holes to fasten drip trays, trap guards for return chains, etc.

See also Setting up the supports for ESD systems, page 186.

## Optional accessories:

Dowel, washer, see p. 112

Alternative feet (see Basic Mechanic Elements catalog, “Feet and wheels” section)

## Scope of delivery:

- **A, E:** Incl. fastening material
- **D:** Set (2 pieces) incl. fastening material

## Condition on delivery:

Not assembled

## Material:

- **A, D:** diecast aluminum, silver
- **B:** aluminum; natural, anodized
- **C:** PA; black
- **E:** steel; galvanized

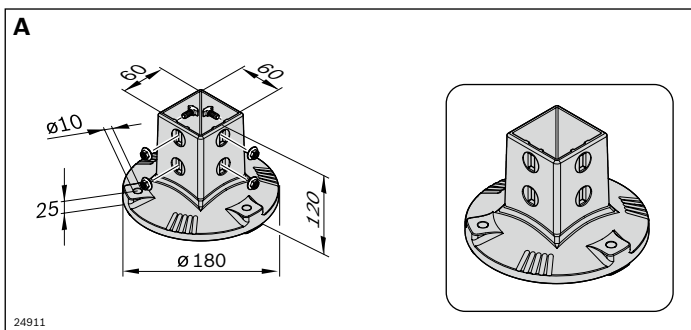

Foot, AL	No.
VFplus 60x60	1 <b>3 842 544 875</b>

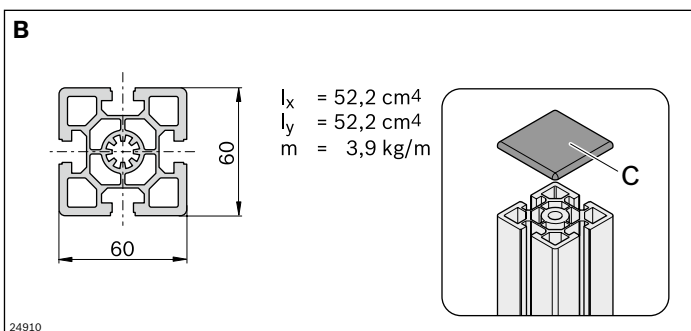

Strut profile AL 60x60	L (mm)	No.
20 pcs	6070	<b>3 842 509 185</b>
1 pcs	50 ... 5600	<b>3 842 990 350/L</b>

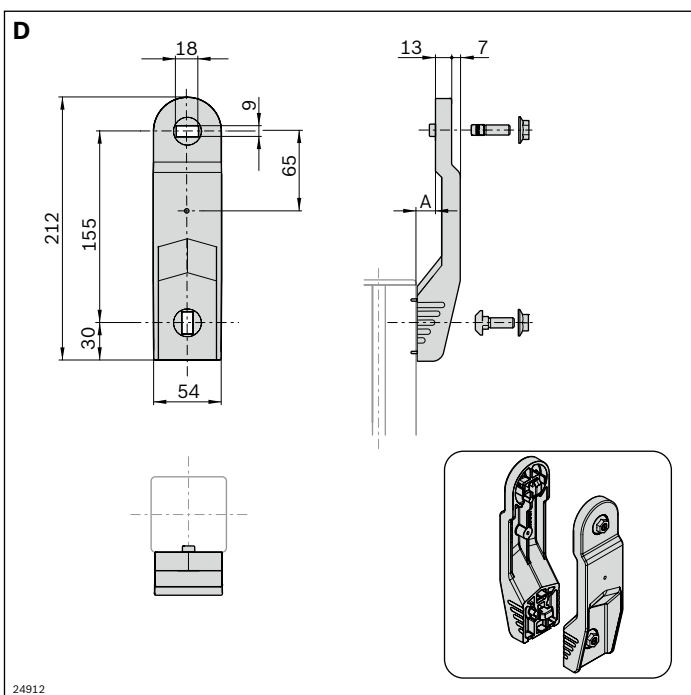

Cover cap	No.
VFplus 60x60, black	100 <b>3 842 511 874</b>

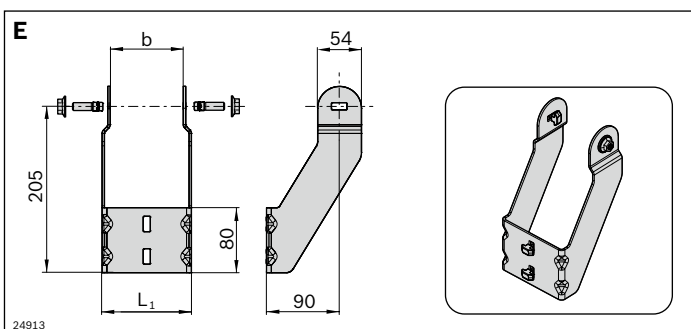

Holder AL	b (mm)	A (mm)	No.
VFplus 65	65	2.5 Set	<b>3 842 546 625</b>
VFplus 90	90	15 Set	<b>3 842 546 626</b>
VFplus 120	120	30 Set	<b>3 842 546 627</b>

Holder motor leg sets AL	b (mm)	L <sub>1</sub> (mm)	No.
VFplus 65	65	85 Set	<b>3 842 547 442</b>
VFplus 90	90	110 Set	<b>3 842 547 443</b>
VFplus 120	120	140 Set	<b>3 842 547 444</b>

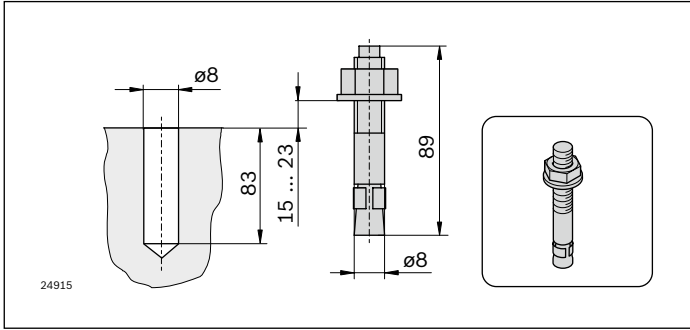

Dowel	No.
	100 <b>3 842 540 668</b>

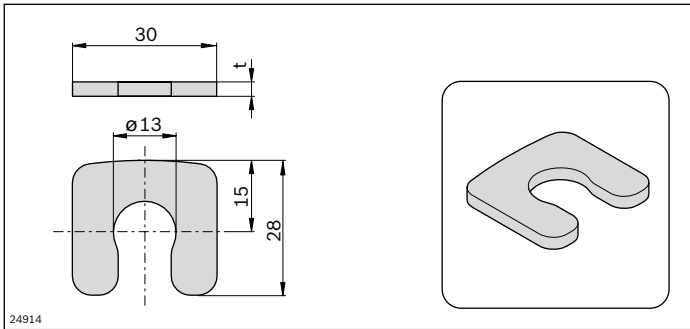

Washer	t (mm)	No.
	1 100	<b>3 842 546 717</b>
	3 20	<b>3 842 546 718</b>

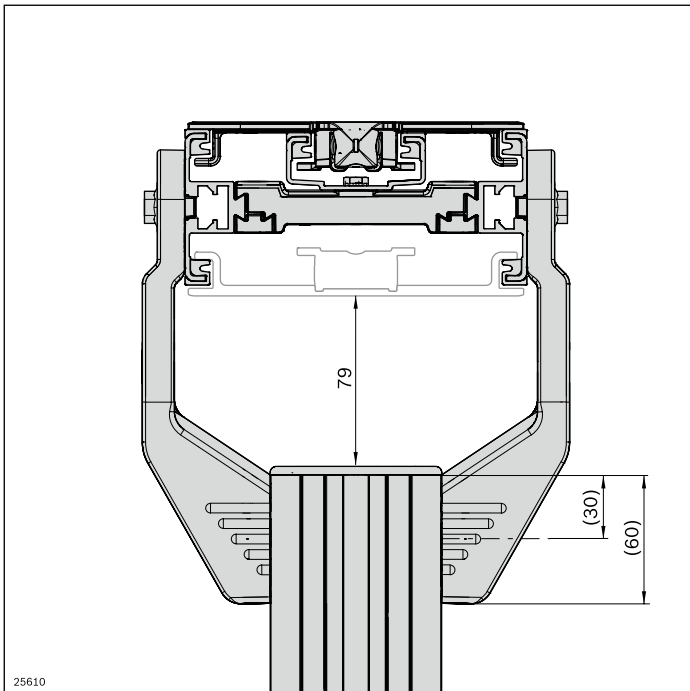

#### Holder adjustment range

The aluminum holder adjustment range shown relates to the standard installation position (holder flush with the profile end) and the use of a flat chain for horizontal running of the chain. For vertical use, the adjustment range is reduced depending on the angle.

# Curve wheel drive support

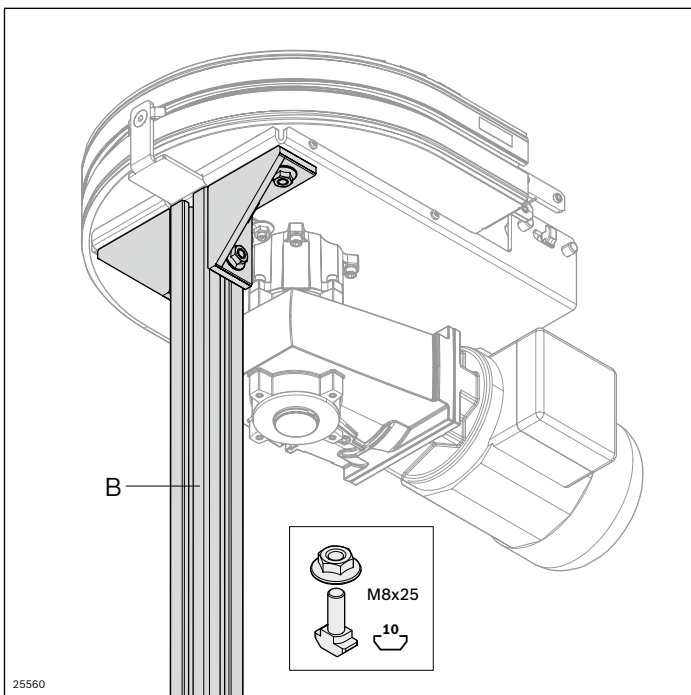

Bracket 40/80	Groove ESD	No.
Set (standard)	10 / 10	1 <b>3 842 529 386</b>
designLINE set	10 / 10	1 <b>3 842 538 717</b>

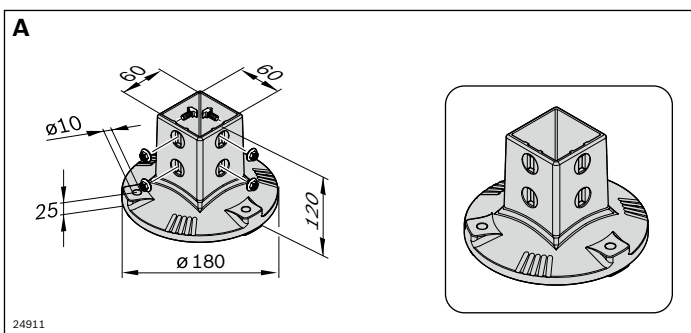

Foot, AL	No.
VFplus 60x60	1 <b>3 842 544 875</b>

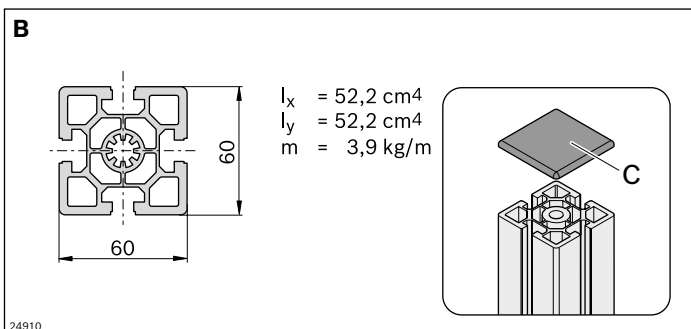

Strut profile AL 60x60	L (mm)	No.
20 pcs	6070	<b>3 842 509 185</b>
1 pcs	50 ... 5600	<b>3 842 990 350/L</b>

Cover cap	No.
VFplus 60x60, black	100 <b>3 842 511 874</b>



## AL leg set 160-320

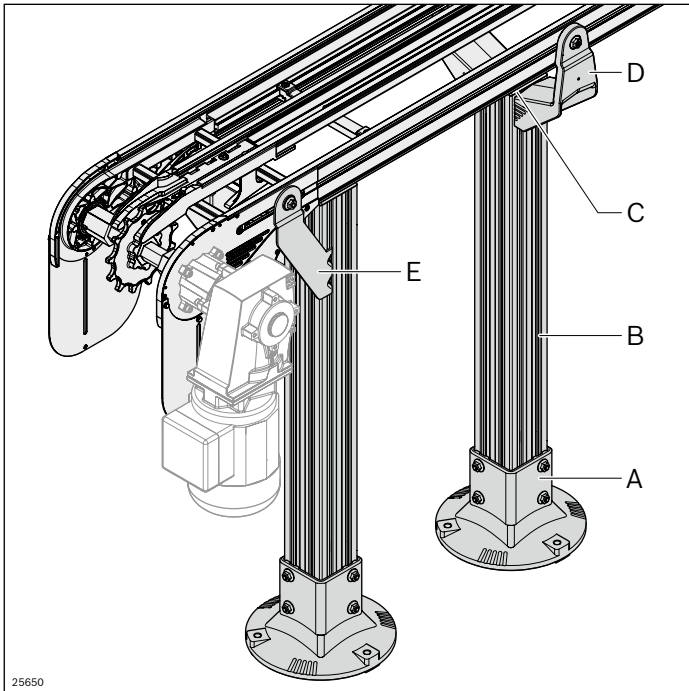

- ▶ Holder is easily centered in the slot thanks to centering lugs (**D**)
- ▶ Very simple assembly with plug-in screw connection (**D**)
- ▶ Easy-to-clean design with draining surfaces

### Optional accessories:

Dowel, washer, see p. 112

Alternative feet (see Basic Mechanic Elements catalog, "Feet and wheels" section)

### Scope of delivery:

- **A, E:** Incl. fastening material
- **D:** Set (2 pieces) incl. fastening material

The chain conveyor is placed on the ground by means of supports (and fastened) or even suspended from the ceiling. The suspension needs to be determined depending on the application.

The floor supports for sizes 160, 240 and 320 are constructed from the following single parts:

Foot 80x80 (**A**), strut profile 80x80L (**B**), cap (**C**), holder for attaching the section profiles (**D**) 160, 240 or 320.

A separate holder (**E**) is used to support the motors / drives

- Depending on the speed, accumulation behavior and weight, the supports are to be fixed at a distance of approx. 2 ... 3 m
- The leg sets for the stainless steel system (see p. 168) may also be used for the aluminum system
- The holder (**E**) may only be used for AL systems
- The height adjustment range is up to 79 mm (**D**), depending on the return chain, see p. 112
- The holder (**D**) can also be used for ascending and descending conveyor sections (up to 45°, depending on the return chain) by removing the centering lugs
- Holder (**D**) with drill guide for additional holes to fasten drip trays, trap guards for return chains, etc.

### Condition on delivery:

Not assembled

### Material:

- **A, D:** diecast aluminum, silver
- **B:** aluminum; natural, anodized
- **C:** PA; black
- **E:** steel; galvanized

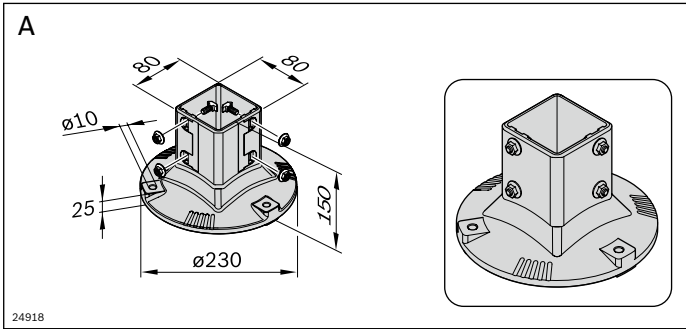

<b>Foot, AL</b>	 <b>No.</b>
VFplus 80x80	1 <b>3 842 540 173</b>

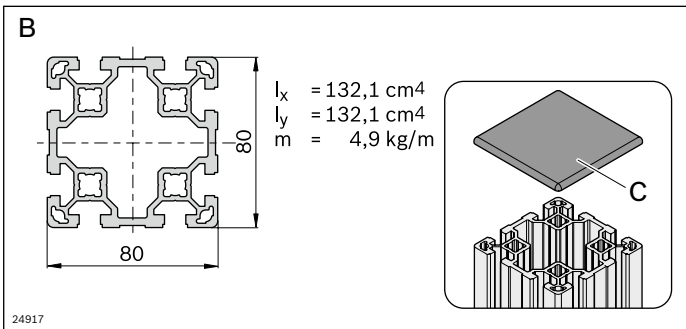

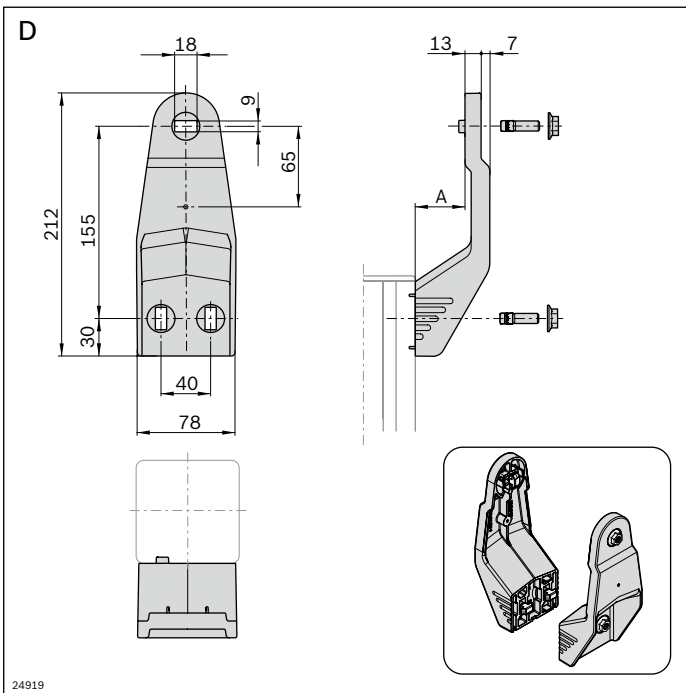

<b>Strut profile AL 80x80 L</b>	<b>L (mm)</b>	<b>No.</b>
 6 pcs	6070	<b>3 842 529 347</b>
1 pcs	50 ... 6000	<b>3 842 993 133/L</b>

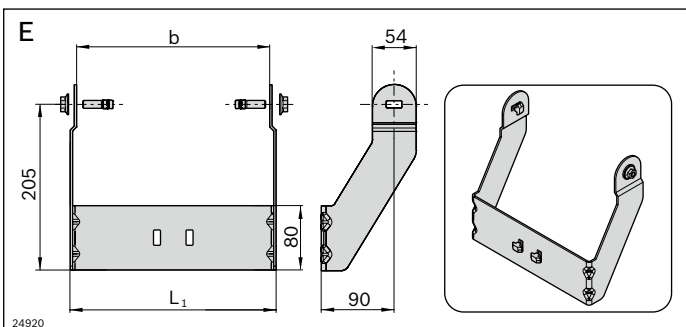

<b>Cover cap</b>	 <b>No.</b>
VFplus 80x80, black	20 <b>3 842 529 039</b>



<b>Holder AL</b>	<b>b (mm)</b>	<b>A (mm)</b>	 <b>No.</b>
VFplus 160	160	40	Set <b>3 842 546 628</b>
VFplus 240	240	80	Set <b>3 842 546 629</b>
VFplus 320	320	120	Set <b>3 842 546 630</b>

<b>Holder engine support AL</b>	<b>b (mm)</b>	<b>L<sub>1</sub> (mm)</b>	 <b>No.</b>
VFplus 160	160	180	Set <b>3 842 547 445</b>
VFplus 240	240	260	Set <b>3 842 547 446</b>
VFplus 320	320	340	Set <b>3 842 547 447</b>

## Supporting bracket AL

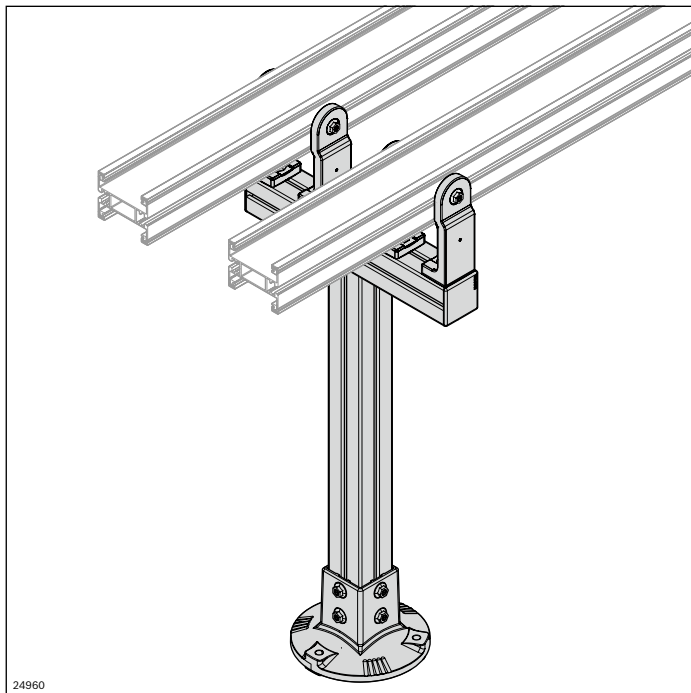

The supporting bracket allows several parallel sections to be mounted on a horizontal profile.

- The distance between the supporting brackets is to be approx. 2-3 m, depending on the speed, accumulation behavior and weight
- The supporting brackets can also be used for ascending and descending conveyor sections (up to 45°, depending on the returning chain) by removing the centering lugs

- ▶ Simple centering of the supporting brackets in the slot thanks to centering lugs
- ▶ Very simple assembly with plug-in screw connections
- ▶ Easy-to-clean design with draining surfaces

Scope of delivery:

Incl. fastening material

Material:

diecast aluminum, silver

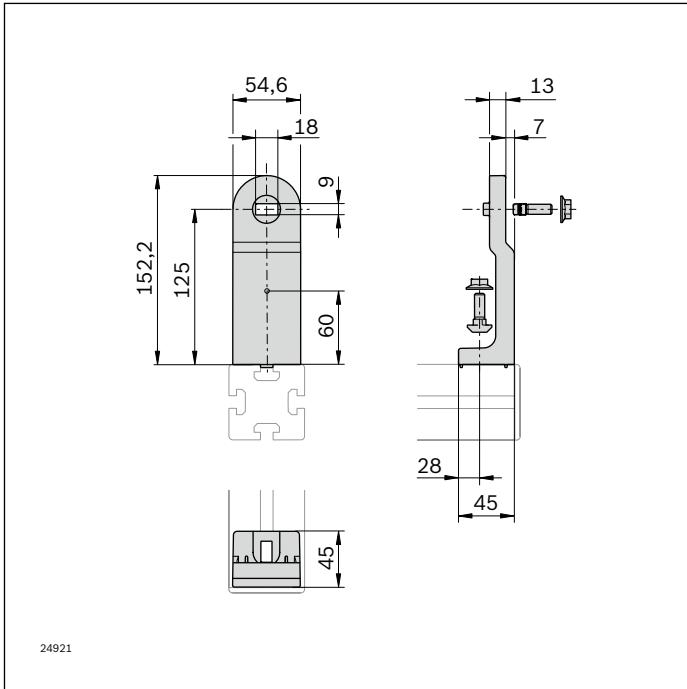

**Supporting bracket VFplus AL**

 **No.**

Set **3 842 546 632**

3

## Supporting bracket, lateral AL

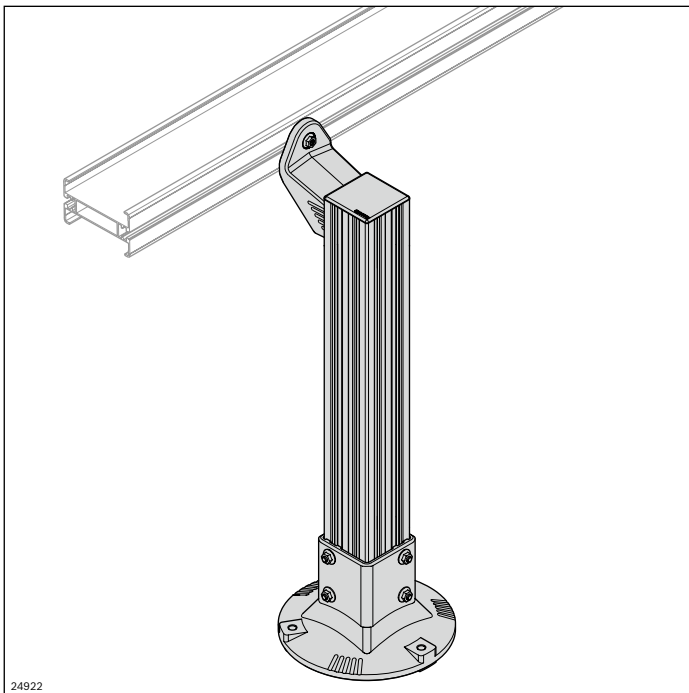

The lateral supporting bracket is provided for the attachment to an 80x80 vertical strut profile. It is suitable for the construction of an alpine conveyor, for example.

- In the case of one-sided attachment, the lateral supporting bracket is only permissible for sizes up to 120
- The lateral supporting bracket can also be used for ascending and descending conveyor sections (up to 45°) by removing the centering lugs

- ▶ Simple centering of the supporting brackets in the slot thanks to centering lugs
- ▶ Very simple assembly with plug-in screw connections

- ▶ Easy-to-clean design with draining surfaces

Scope of delivery:

Incl. fastening material

Material:

diecast aluminum, silver

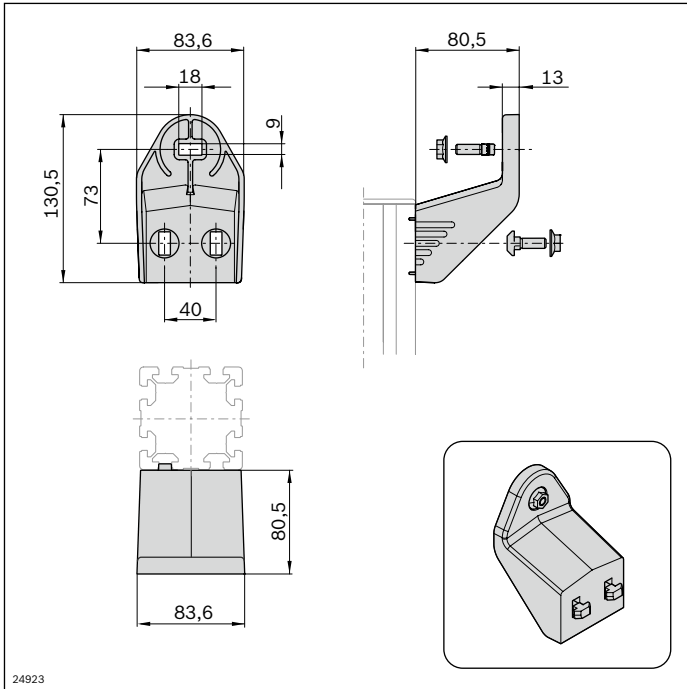

<b>Supporting bracket VFplus lateral AL</b>		<b>No.</b>
	Set	<b>3 842 547 461</b>



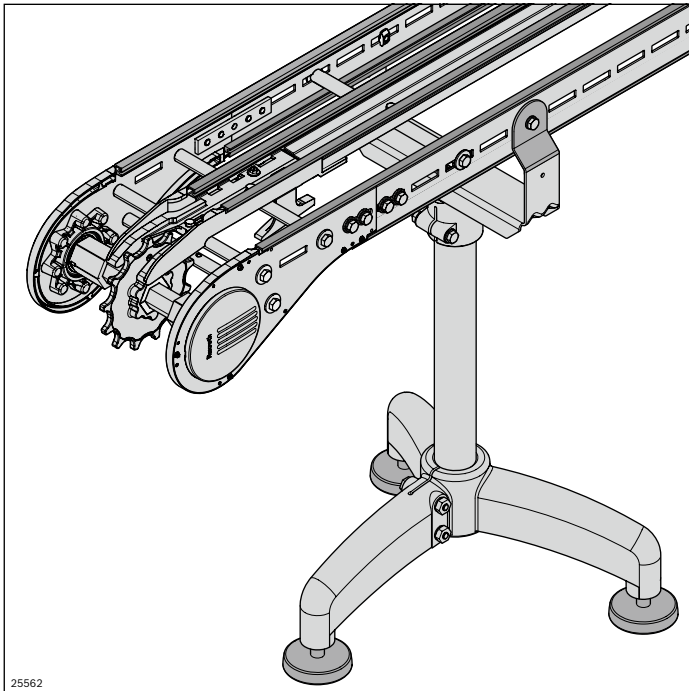

# VarioFlow *plus* Stainless steel system (STS)



- ▶ Fixing of slide rails without rivets or the need to machine the track bearing surfaces
- ▶ Minimal slide rail interruptions
- ▶ FDA-compliant, low-friction materials for components subject to constant friction
- ▶ Standardized components that can be used universally
- ▶ Continuous product range in the sizes 65, 90, 120, 160, 240, 320

25562

FDA-compliant materials and easy-to-clean surfaces fulfill the high standards in the areas of the food & packaging and health & care industries, where hygiene is critical.

	<b>Sections STS</b>	<b>122</b>
	<b>Curves STS</b>	<b>134</b>
	<b>Drive and return unit STS</b>	<b>142</b>
	<b>STS leg sets</b>	<b>166</b>

## Sections STS

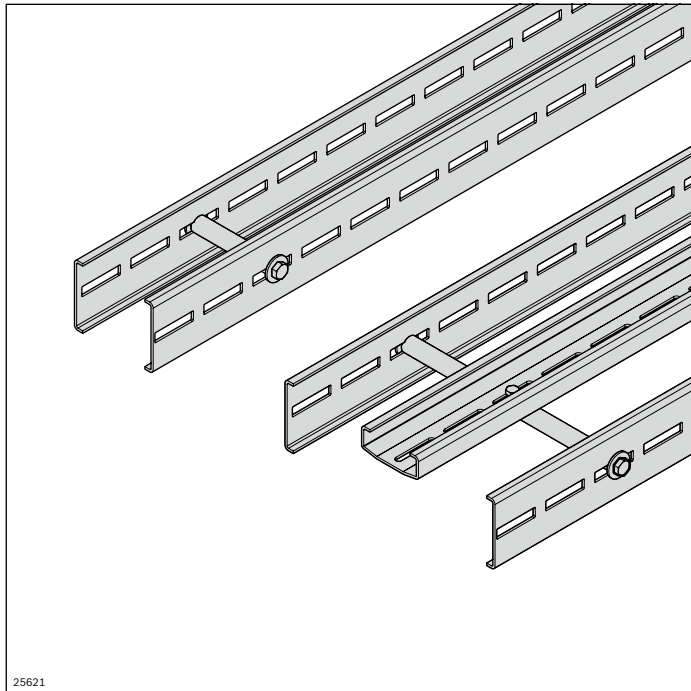

- ▶ Fixing of slide rails without rivets or the need to machine the track bearing surfaces
- ▶ Optimized sliding characteristics and FDA-compliant materials for the slide rail
- ▶ One slide rail cross-section for all sizes
- ▶ Few screwed connections
- ▶ One profile cross-section for all sizes
- ▶ Use of a support profile from size 160

25621

Easy-to-clean sections due to largely media-resistant components

	<b>Section profile STS open</b>	<b>124</b>
	<b>Section profile STS Clean</b>	<b>126</b>
	<b>Slide rail</b>	<b>128</b>
	<b>Steel slide rail</b>	<b>130</b>
	<b>Profile connector STS</b>	<b>132</b>
	<b>Assembly module STS</b>	<b>133</b>

# Section profile STS open

## Cross connector STS

## Support profile STS

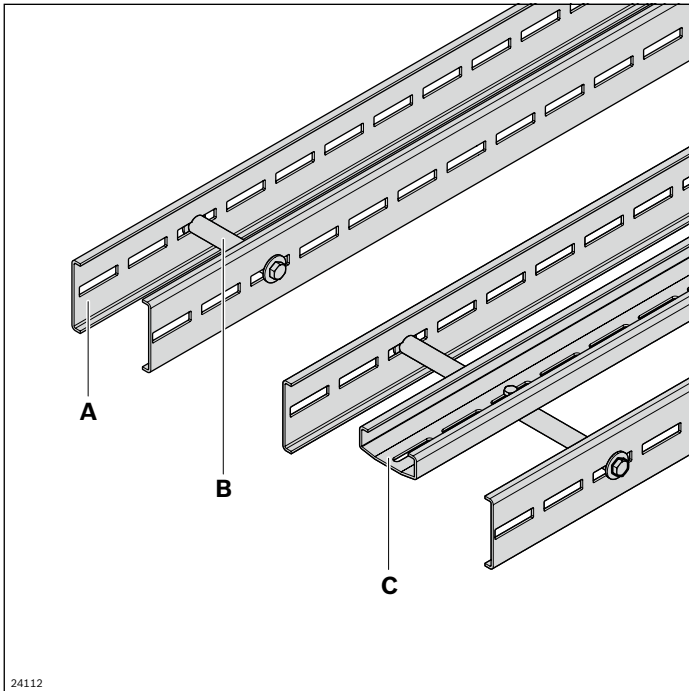

The open construction of the section profile **(A)** facilitates the direct discharge of dirt or foreign particles.

Two open section profiles, linked by cross connectors, are needed to construct a conveyor section. A support profile is necessary for sizes 160 and over.

- Same profile cross-section across all sizes (65-320)

The cross connector **(B)** is the connection of two profile halves to make an open section profile. Using cross connectors of different lengths determines the size.

A support profile **(C)** is required as of size 160. The support profile is fastened to the existing cross connectors.

### STS open section profile (A)

- ▶ Elongated holes for attaching a drive/return unit, curves, lateral guides, leg sets, or other accessories
- ▶ Simple to clean

### STS cross connector (B)

- ▶ Cross connector with mounting option for support profile

Required accessories:

- **A:** Slide rail, see p. 128; profile connector, see p. 132; cross connector, see p. 124; support profile from size 160, see p. 124

Scope of delivery:

- B:** Incl. fastening material

### STS support profile (C)

- ▶ With elongated holes for fastening in regular intervals
- ▶ Plug-through stainless steel T-nuts as mounting option on the section profile

Material:

- A, B, C:** Non-rusting steel 1.4301

Condition on delivery:

- A, B:** Not assembled

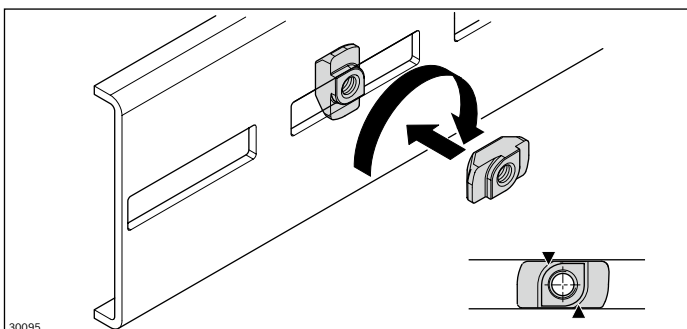
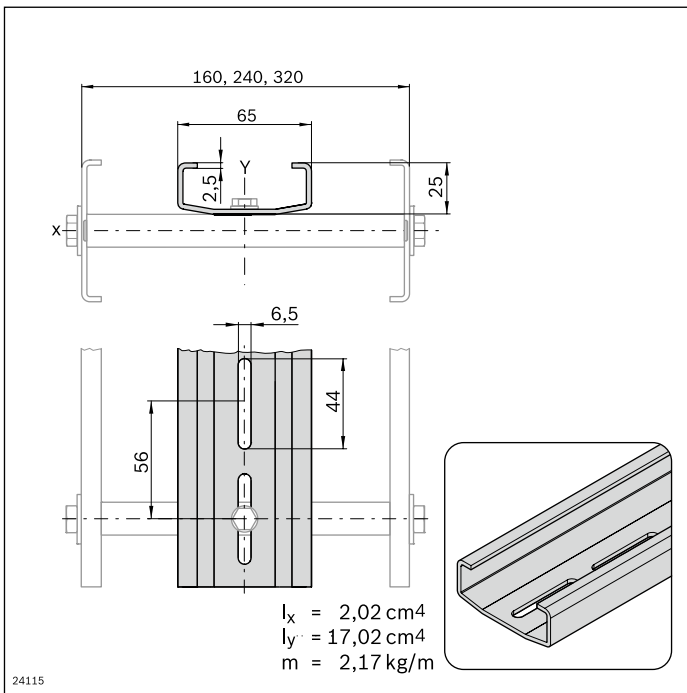
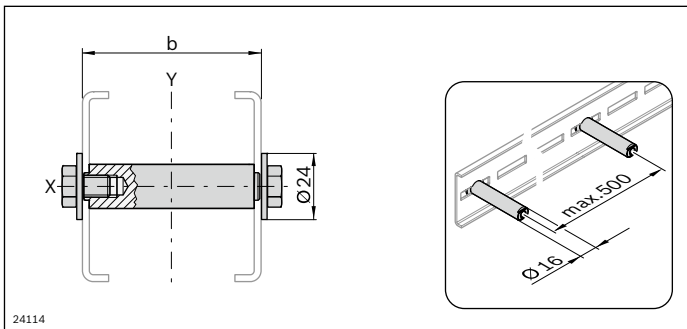
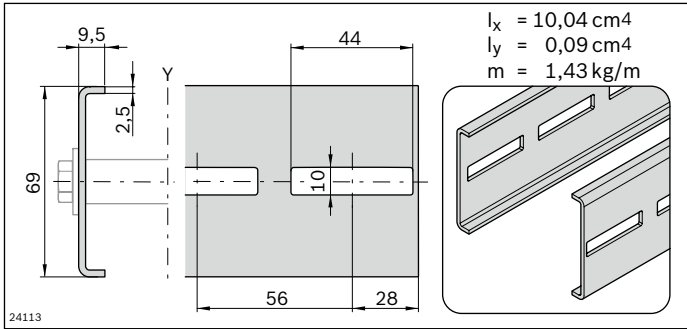

Section profile VFplus STS open	L (mm)	No.
12 pcs	3024	<b>3 842 546 649</b>
2 pcs	3024	<b>3 842 547 905</b>
1 pcs	75 ... 3000	<b>3 842 996 027/L</b>

Cross connector STS	b (mm)	No.
VFplus 65 STS	65	10 <b>3 842 546 684</b>
VFplus 90 STS	90	10 <b>3 842 546 685</b>
VFplus 120 STS	120	10 <b>3 842 546 686</b>
VFplus 160 STS	160	10 <b>3 842 546 687</b>
VFplus 240 STS	240	10 <b>3 842 546 688</b>
VFplus 320 STS	320	10 <b>3 842 546 689</b>

Support profile VFplus STS	L (mm)	No.
12 pcs	3024	<b>3 842 546 700</b>
1 pcs	3024	<b>3 842 547 906</b>
1 pcs	75 ... 3000	<b>3 842 996 029/L</b>

Standard element for the secure connection of accessory parts to the section profile

**Note:** MGE T-nuts do not fit in the STS section profile.

T-nut	No.
VFplus STS M6	20 <b>3 842 546 706</b>
VFplus STS M8	20 <b>3 842 546 707</b>

## Section profile STS Clean

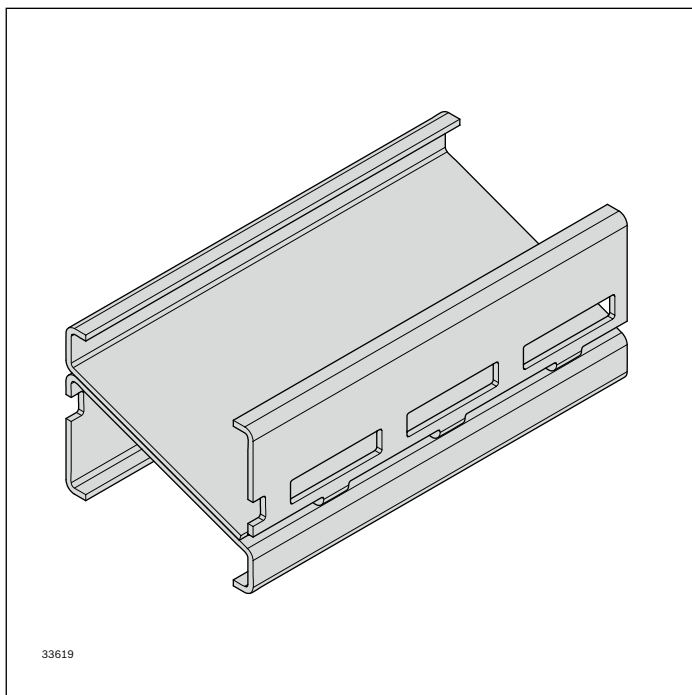

The construction of the STS Clean section profile allows for the direct discharge of dirt or foreign particles without them reaching the returning chain.

- Size: 90
- For use in harsh production environments

**Note:** Not compatible with the AL system

- ▶ Elongated holes for attaching a drive/return unit, curves, lateral guides, leg sets and other accessories
- ▶ Simple to clean

Required accessories:

- Profile connector STS Clean section, see p. 127
- Slide rail, see page 128

Optional accessories:

- T-nut VFplus STS, see p. 125

Material:

Non-rusting steel 1.4301



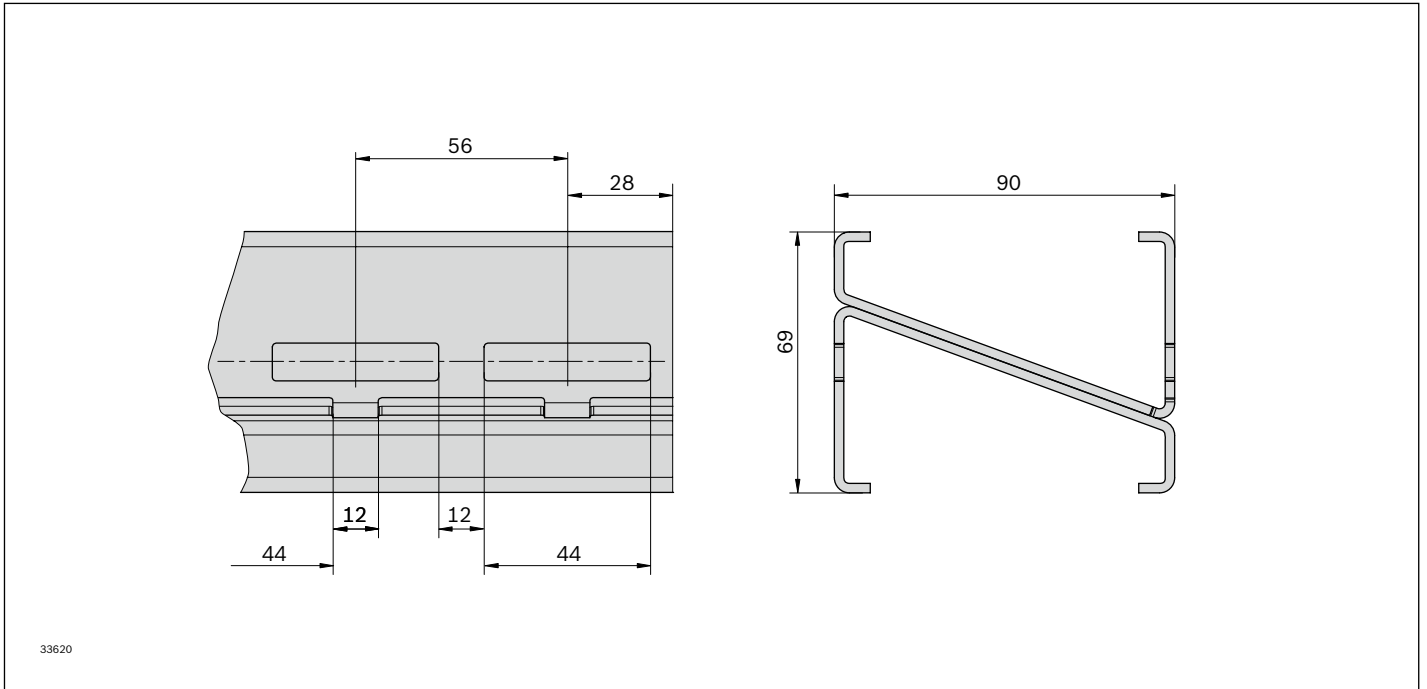

Section profile STS Clean	L (mm)		No.
	3024	1	3 842 553 006
	75 ... 3000	1	3 842 996 314
Profile connector STS Clean section	H (mm)		No.
	17	10	3 842 552 927

**Note:** When using the section profile STS Clean with the basic units (head drive, return unit, connection drive) the enclosed profile connector (H = 20 mm) must be replaced with the profile connector STS Clean section (H = 17 mm) 3 842 552 927.

## Slide rail

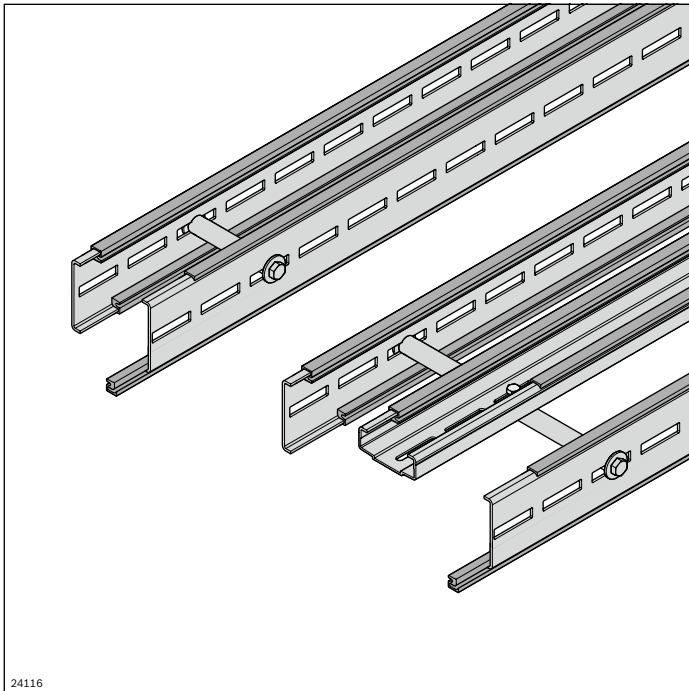

- ▶ Easy assembly - simply clip onto the section profile
- ▶ Secured against axial shifting with lateral screw fittings
- ▶ Gliding surface machining: not required
- ▶ Material
  - Premium, Advanced slide rails: FDA CFR 21
  - with Basic slide rail: EU 10/2011, FDA CFR 21
- ▶ One cross-section for all AL and STS section profiles

### Required accessories:

- Slide rail assembly tool, see page 264
- Oval-head screw 2.9x9.5 DIN 7981; DIN EN ISO 7049  
see page 129
- 1 screw for each slide rail section

### Material:

PE-UHMW

The slide rail is clipped into the section profile and guides the conveyor chain.

Lateral securing means the gliding surface does not need to be machined. Abrasion and noise levels are thus reduced to a minimum.

Three slide rails with different main areas of application are available:

- Basic: straight sections and curve wheels,  $v_{\max}$  60 m/min
- Advanced: Sections with sliding curves,  $v_{\max}$  60 m/min, cleanroom
- Premium: Sections with sliding curves,  $v_{\max}$  100 m/min, cleanroom

For the selection of slides rails, see the “Technical data” chapter on page 268. See also ESD slide rail on page 178 and steel slide rails on page 130.

Extend the slide rail over the component interfaces to ensure minimum wear and noise emissions. Interruptions to the profile or component connection must be avoided. If an interruption is necessary after 10 m, the slide rail must be attached laterally with a sheet metal screw (**A**).

**Note:** After the sliding curves, an interruption is provided as an expansion joint in the inner curve area.

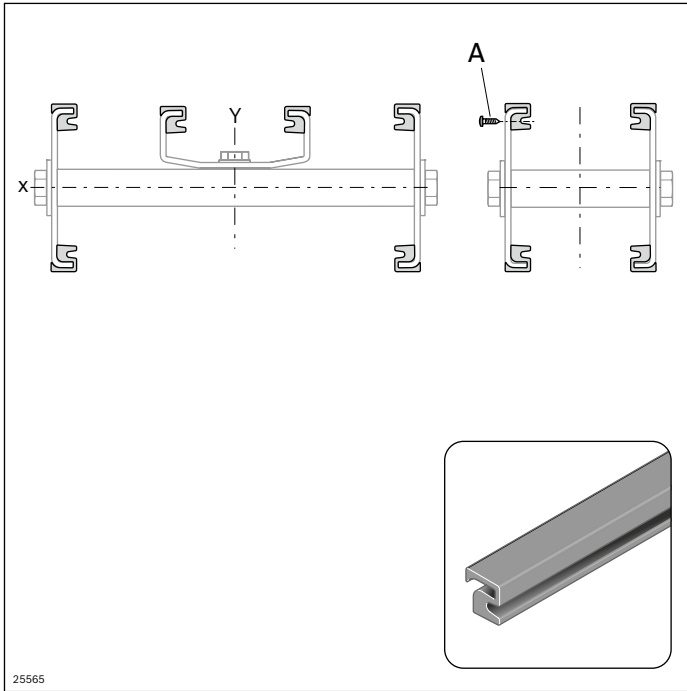

25565

<b>Slide rail VFplus</b>	<b>Color</b>	<b>L (mm)</b>		<b>No.</b>
Premium	gray	30000	1	<b>3 842 546 116</b>
Advanced	white	30000	1	<b>3 842 549 727</b>
Basic	blue	30000	1	<b>3 842 549 730</b>

See also ESD slide rail, see page 178  
and steel slide rail, see page 130.

<b>Oval-head screw</b>		<b>No.</b>
<b>A</b>	100	<b>3 842 533 915</b>

## Steel slide rail

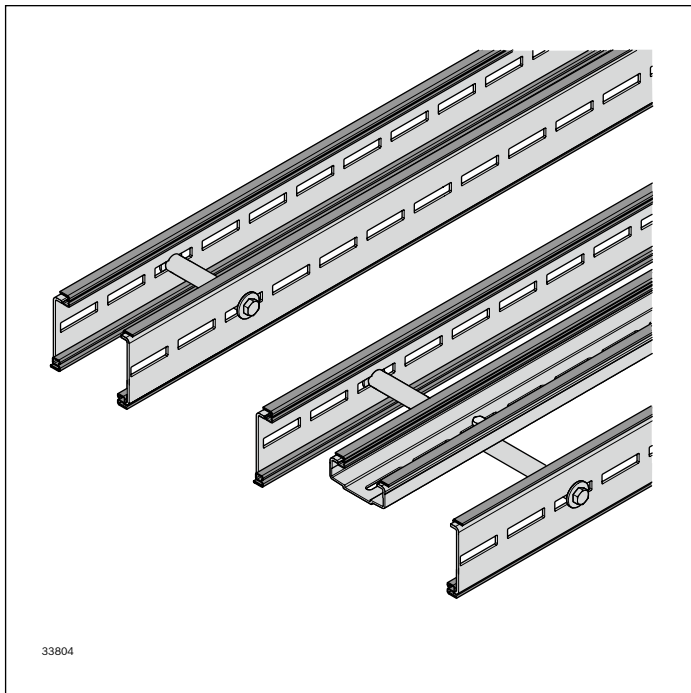

- ▶ Easy assembly - simply clip onto the section profile
- ▶ Secured against axial shifting via lateral fixing
- ▶ Gliding surface machining: not required
- ▶ One cross-section for all AL and STS section profiles

### Required accessories:

- Pop rivet D3x8 mm, see page 131
- Number of rivets:
  - Straight slide rail section: 1 rivet
  - 90° curve: 3 rivets
  - 180° curve: 6 rivets

### Material:

Stainless steel

The steel slide rail is suitable for use in abrasive ambient conditions (reduced service life of the conveyor chain). It is clipped in to the section profile and fixed in place at the side via a pop rivet.

The side fixing reduces the friction and the noise level to a minimum. The steel slide rail butt joints are merely chamfered. The Advanced slide rail is used in the lower run of the curve wheels.

- Steel slide rail straight section (**A**)
- Steel slide rail curve wheels (**B**) 90°, 180°; other angles on request
- Dry, wet and abrasive environment
- Size:
  - Straight section 160-320
  - Curve wheel 65-90; 120 on request
- Not suitable for use in horizontal sliding curves
- Only Advanced or Premium slide rails can be used in vertical curves

**Note:** Ensure gap-free assembly (without expansion joint), as foreign bodies could otherwise get trapped in the gap and damage the chain.

**Note:** Non-destructive dismantling of the steel slide rail is not possible. A target separation point of the system must therefore be defined before assembly. Overlap the steel slide rail by 10 ... 15 mm on the section profile separation point. This ensures that it is still possible to pull apart the two parts.

Extend the steel slide rail over the component interfaces to ensure minimum wear and reduced noise emissions. Interruptions directly on the profile or component connection must be avoided.

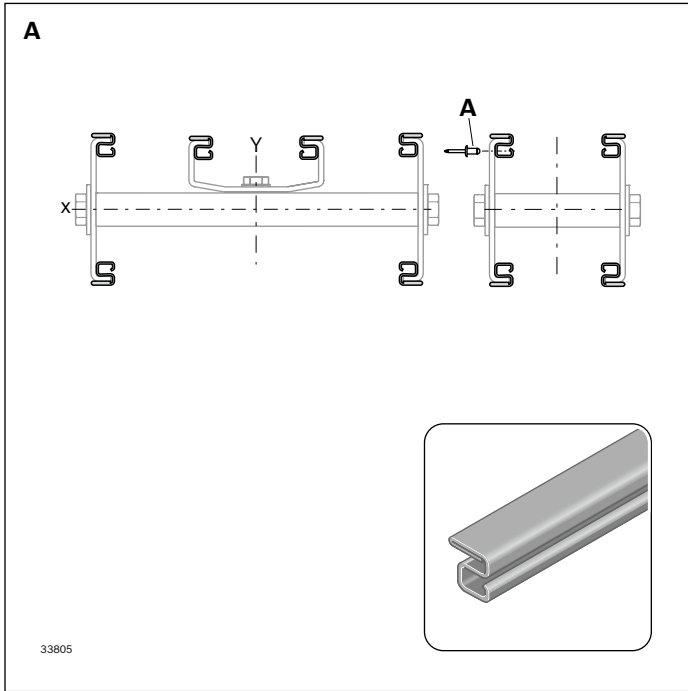

Slide rail VFplus steel	L (mm)	No.
A Straight section	3000	1 <b>3 842 552 970</b>

Pop rivet	No.
C	100 <b>3 842 557 004</b>

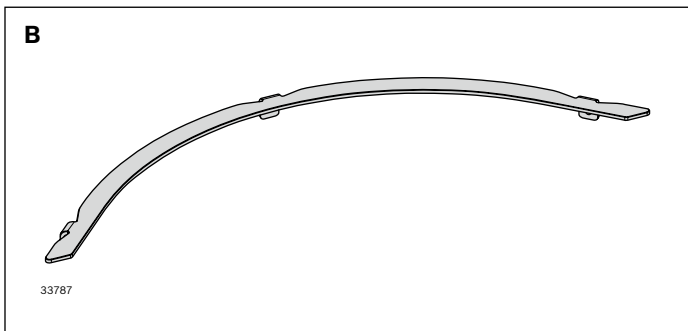

Steel slide rail; curve wheel VFplus 65	No.
B Steel 90°	1 <b>3 842 552 972</b>
B Steel 180°	1 <b>3 842 552 973</b>

Steel slide rail; curve wheel VFplus 90	No.
B Steel 90°	1 <b>3 842 552 974</b>
B Steel 180°	1 <b>3 842 552 975</b>

Pop rivet	No.
C	100 <b>3 842 557 004</b>

## Profile connector STS

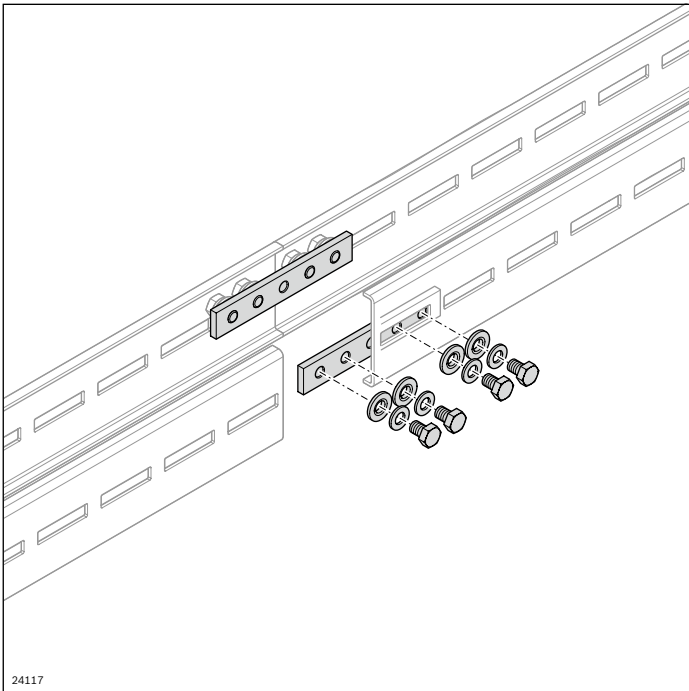

Two profile connectors are used to connect the end faces of the section profiles.

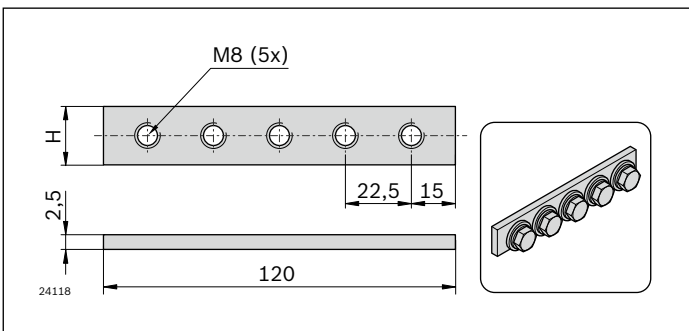

Profile connector VFplus STS	H (mm)	No.
	20	10 <b>3 842 547 895</b>

Profile connector STS Clean section	H (mm)	No.
	17	10 <b>3 842 552 927</b>

Scope of delivery:  
Complete

Scope of delivery:  
Not assembled

Material:  
Non-rusting steel 1.4301

# Assembly module STS



4

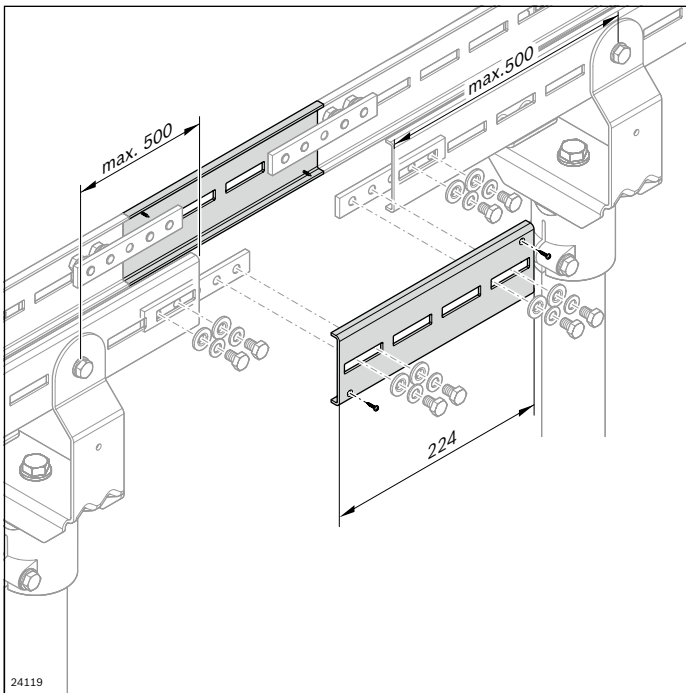

The assembly module is used for inserting and closing or opening the chain. It can be installed at any point on the conveyor section that is easy to access in operation. The assembly module is intended for sections with drives without a chain bag (e.g. wedge conveyor).

- Max. distance from the nearest leg sets on both sides is 500 mm
- The support profile with slide rail is not interrupted in the assembly module, enhancing smooth running
- Slide rail interruption is only required on the side to be opened

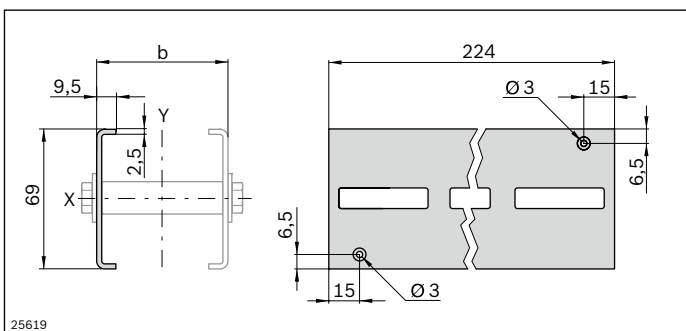

	L (mm)	No.
Assembly module VFplus STS	1	<b>3 842 547 900</b>
Slide rail VFplus Premium	30000	<b>1 3 842 546 116</b>
Slide rail VFplus Advanced	30000	<b>1 3 842 549 727</b>
Slide rail VFplus Basic	30000	<b>1 3 842 549 730</b>
Slide rail VFplus steel	3000	<b>1 3 842 552 970</b>
Slide rail VFplus ESD	30000	<b>1 3 842 557 000</b>

Required accessories:

Slide rail, see p. 128, 130, 178

Scope of delivery:

Incl. 4 profile connectors and sheet-metal screws for fastening the slide rail

Material:

Non-rusting steel 1.4301

Condition on delivery:

In single parts



## Curves STS

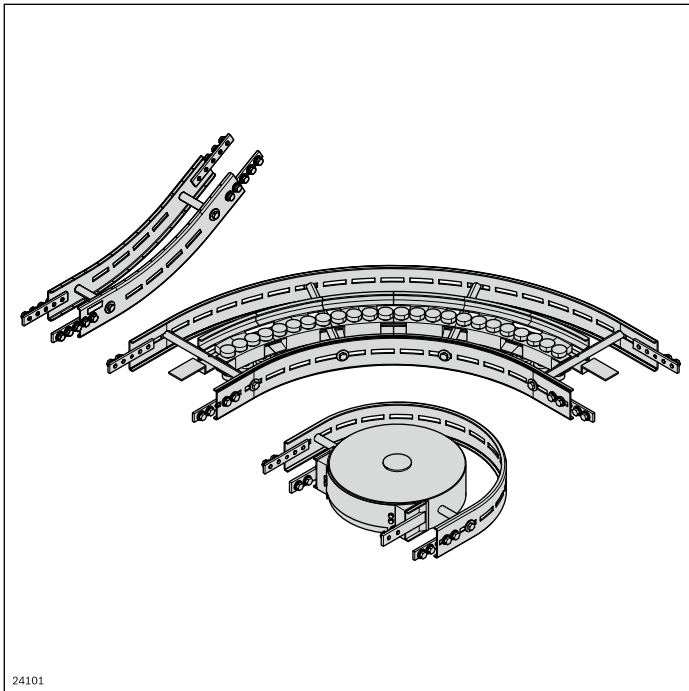

- ▶ Components subject to constant friction feature FDA-compliant materials
- ▶ Easy to clean thanks to ample draining surfaces
- ▶ Capable of accumulation
- ▶ Reduced friction on curve wheels and patented roller curves to minimize wear, meaning the implementation of longer sections
- ▶ Stainless steel ball bearings sealed on both sides with FDA-compliant special grease in curve wheels and patented roller curves

Longer service life and reduced downtimes  
thanks to low-friction curve technology

	<b>Curve wheel STS</b>	<b>136</b>
	<b>Roller curve horizontal STS</b>	<b>138</b>
	<b>Vertical curve STS</b>	<b>140</b>

## Curve wheel STS

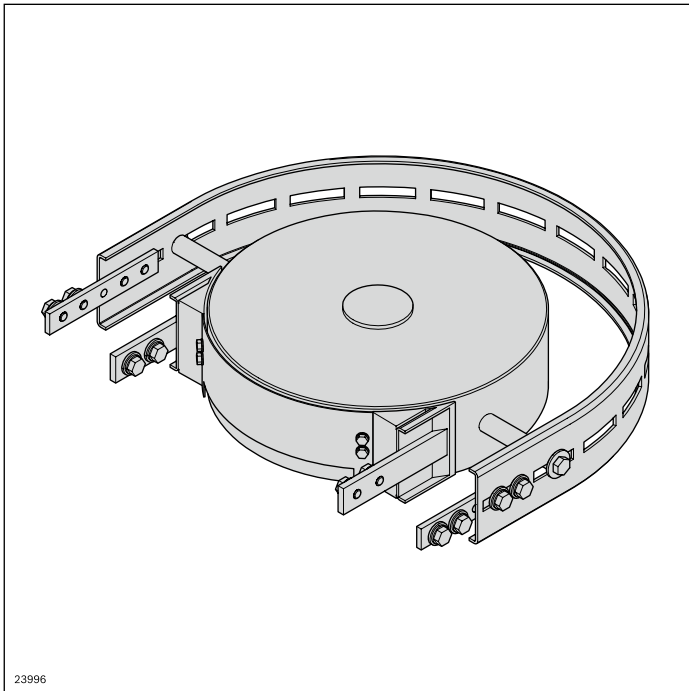

The curve wheel provides a horizontal direction change for the chain. It enables low-friction direction changes with very small radii.

For attachment options, see the matrix on page 289

- Size: 65, 90, 120
- For deflection angles, see table
- Other deflection angles on request
- Suitable chain types: all

**Note:** High-pressure cleaning of the ball bearing areas is not permitted.

- ▶ Easy-to-clean design
- ▶ Stainless steel ball bearings, with sealing on both sides and FDA-compliant lubrication
- ▶ Surfaces in contact with chain made of FDA-compliant materials

- ▶ No interfering contours above chain plate height
- ▶ Can be used horizontally and vertically (for wedge conveyors)

Scope of delivery:

Incl. fastening material for mounting to STS section profiles

Condition on delivery:

Fully assembled

Material:

- Housing: Stainless steel, 1.4301
- Chain wheel: PA; white
- Ball bearings: Stainless steel/ FDA

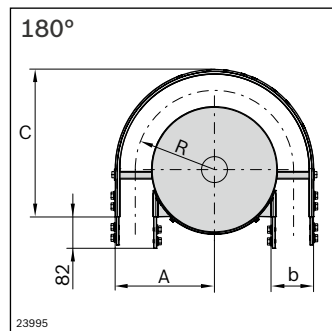
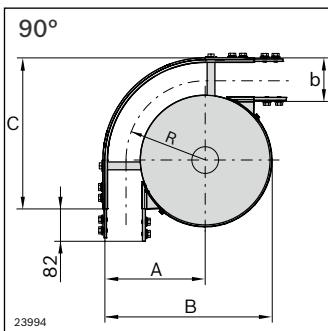
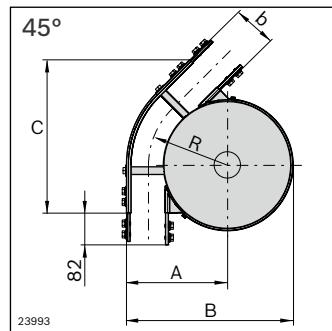
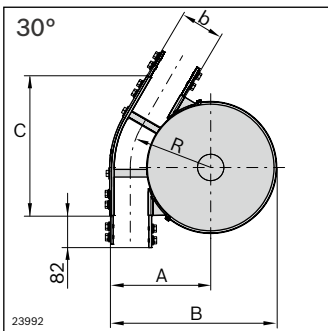
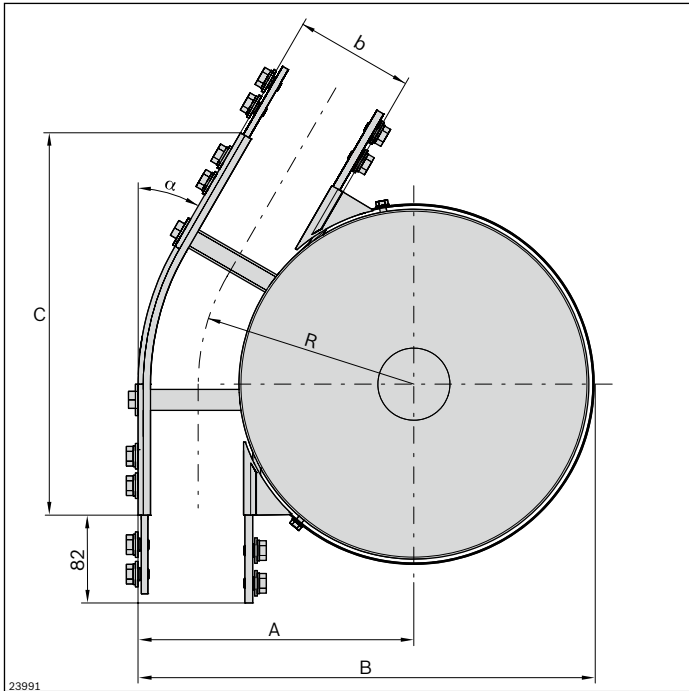

Curve wheel STS	$\alpha$ (°)	No.
VFplus 65	30	<b>3 842 547 111</b>
	45	<b>3 842 547 112</b>
	90	<b>3 842 547 113</b>
	180	<b>3 842 547 114</b>
VFplus 90	30	<b>3 842 547 115</b>
	45	<b>3 842 547 116</b>
	90	<b>3 842 547 117</b>
	180	<b>3 842 547 118</b>
VFplus 120	30	<b>3 842 547 119</b>
	45	<b>3 842 547 120</b>
	90	<b>3 842 547 121</b>
	180	<b>3 842 547 122</b>

<b>b</b> (mm)	$\alpha$ (°)	<b>R</b> (mm)	<b>A</b> (mm)	<b>B</b> (mm)	<b>C</b> (mm)
65	30	153.0	185.5	322.5	279.4
	45	153.0	185.5	322.5	301.9
	90	153.0	185.5	322.5	285.5
	180	153.0	185.5	-	287.5
90	30	165.5	210.5	347.5	291.9
	45	165.5	210.5	347.5	319.6
	90	165.5	210.5	347.5	310.5
	180	165.5	210.5	-	310.5
120	30	180.5	240.5	377.5	306.9
	45	180.5	240.5	377.5	340.8
	90	180.5	240.5	377.5	340.5
	180	180.5	240.5	-	340.5

## Roller curve horizontal STS

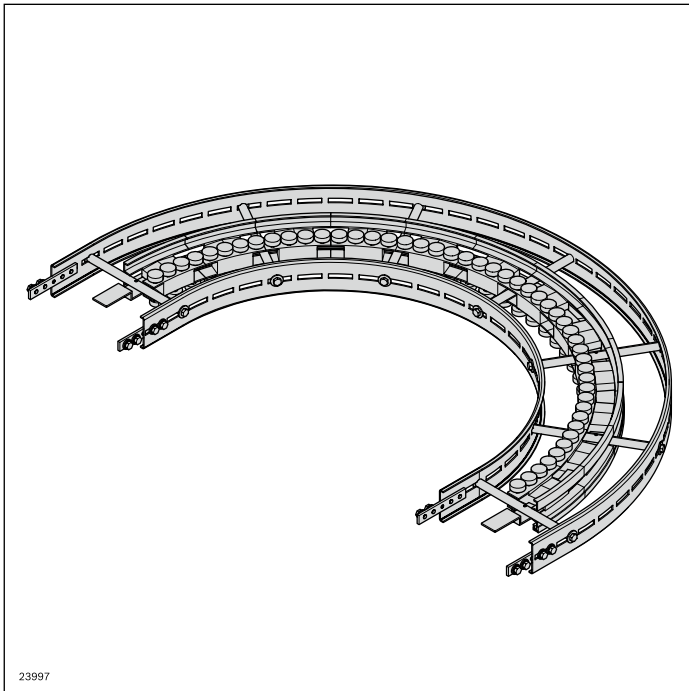

The low-friction roller curve provides a horizontal change in direction for the chain. Polymer-coated roller elements with ball bearings enable longer conveyor sections. The service life of the chain is increased and system costs reduced. For attachment options and length determination of the support profile, see matrix on page 289

- Size: 160, 240, 320
- See table for the deflection angles, more deflection angles available on request
- Deflection radius: R500
- Suitable chain types: all
- Version with open section profiles

**Note:** High-pressure cleaning of the ball bearing areas is not permitted.

- ▶ Patented roller elements for low-friction, quieter changes in chain direction
- ▶ Easy-to-clean design
- ▶ Stainless steel ball bearings, with sealing on both sides and FDA-compliant lubrication

- ▶ Surfaces in contact with chain made of FDA-compliant materials

Required accessories:

Slide rail: Length calculation, see page 278

Scope of delivery:

Incl. fastening material for mounting to STS section profiles

Condition on delivery:

Fully assembled

Material:

- Profile: Stainless steel, 1.4301
- Roller carrier: PA66
- Ball bearings: Stainless steel/ FDA
- Connector: Stainless steel, 1.4301
- Rollers: PA

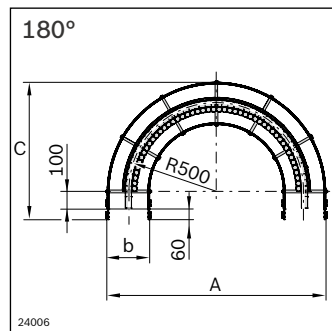
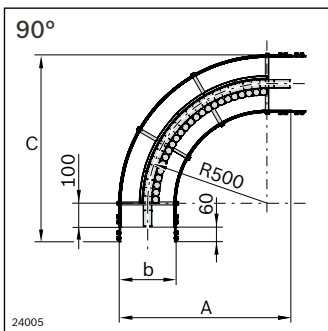
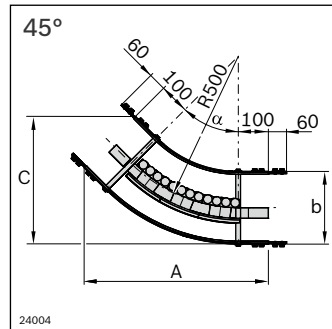
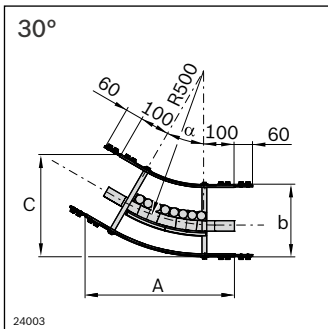
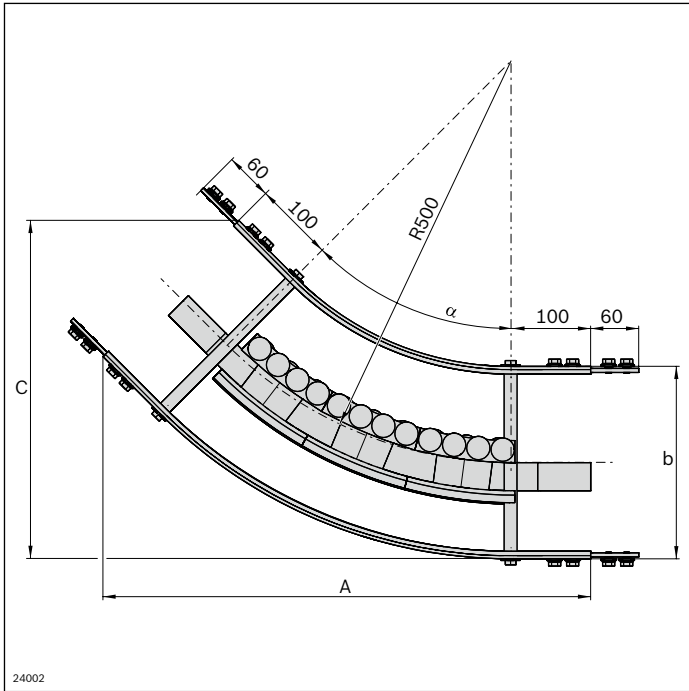

Roller curve STS	$\alpha$ (°)	No.
VFplus 160	30	<b>3 842 547 123</b>
	45	<b>3 842 547 124</b>
	90	<b>3 842 547 125</b>
	180	<b>3 842 547 126</b>
VFplus 240	30	<b>3 842 547 127</b>
	45	<b>3 842 547 128</b>
	90	<b>3 842 547 129</b>
	180	<b>3 842 547 130</b>
VFplus 320	30	<b>3 842 547 131</b>
	45	<b>3 842 547 132</b>
	90	<b>3 842 547 133</b>
	180	<b>3 842 547 134</b>

b (mm)	$\alpha$ (°)	A (mm)	C (mm)
160	30	476.6	266.3
	45	580.8	353.7
	90	680.0	680.0
	180	1160.0	680.0
240	30	496.6	340.9
	45	609.1	422.0
	90	720.0	720.0
	180	1240.0	720.0
320	30	516.6	415.6
	45	637.4	490.3
	90	760.0	760.0
	180	1320.0	760.0

## Vertical curve STS

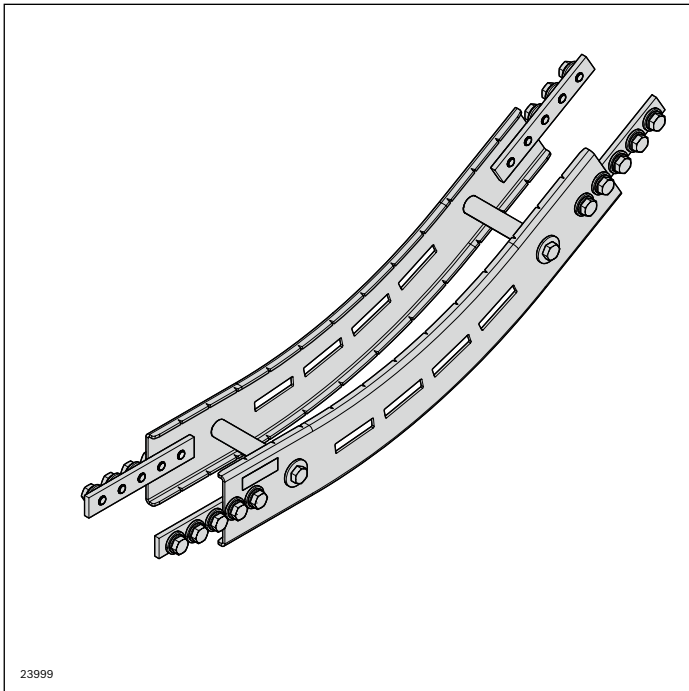

The vertical curve is used for the transition from a horizontal conveyor section to an ascending section and vice versa. The chain tensile force is increased through the ensuing friction.

A vertical curve of 5° is recommended for the infeed and outfeed on the wedge conveyor, especially with small products.

For attachment options, see the matrix on page 289

- Size: all
- Deflection angles and radii see table, other deflection angles and radii on request
- Suitable chain types: all
- Version with open section profiles
- Requires the use of the Advanced or Premium slide rails

Required accessories:

Slide rail: Length calculation, see page 278

Scope of delivery:

Incl. fastening material for mounting to STS section profiles

Condition on delivery:

Fully assembled

Material:

- Profile: Stainless steel, 1.4301
- Connector: Stainless steel, 1.4301
- Support profile from size 160: Stainless steel, 1.4301



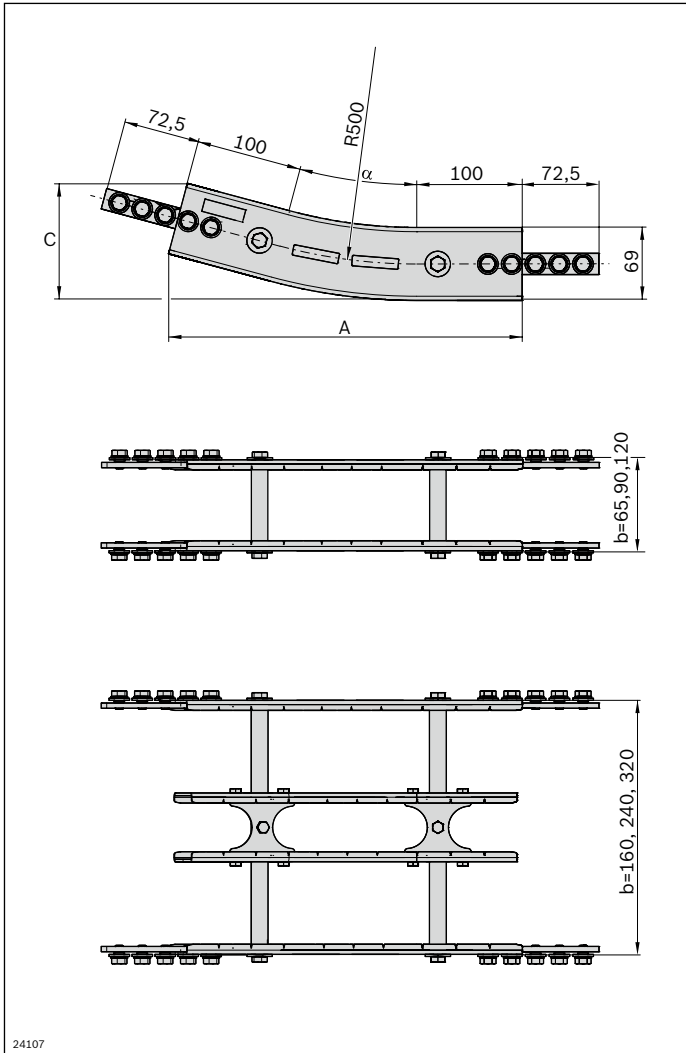

Vertical curve STS	$\alpha$ (°)	No.
VFplus 65	5	3 842 547 135
	15	3 842 547 136
	30	3 842 547 137
	45	3 842 547 138
VFplus 90	5	3 842 547 139
	15	3 842 547 140
	30	3 842 547 141
	45	3 842 547 142
VFplus 120	5	3 842 547 143
	15	3 842 547 144
	30	3 842 547 145
	45	3 842 547 146
VFplus 160	5	3 842 547 147
	15	3 842 547 148
	30	3 842 547 149
	45	3 842 547 150
VFplus 240	5	3 842 547 151
	15	3 842 547 152
	30	3 842 547 153
VFplus 320	5	3 842 547 154
	15	3 842 547 155
	30	3 842 547 156

b (mm)	$\alpha$ (°)	R (mm)	A (mm)	C (mm)
65-320	5	500	246.2	79.5
	15	500	334.9	110.7
	30	500	453.9	181.4
65-160	45	500	548.7	276.1



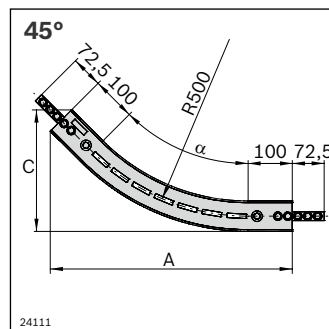
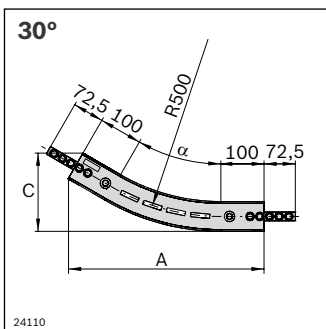
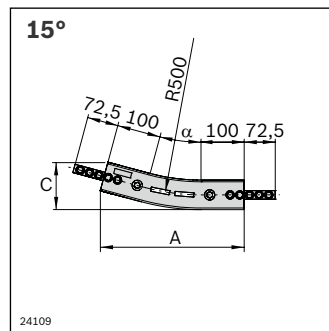
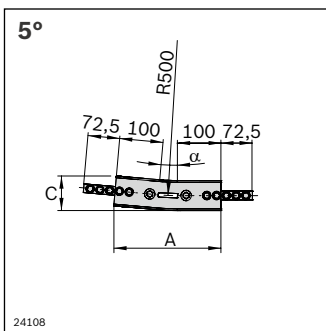



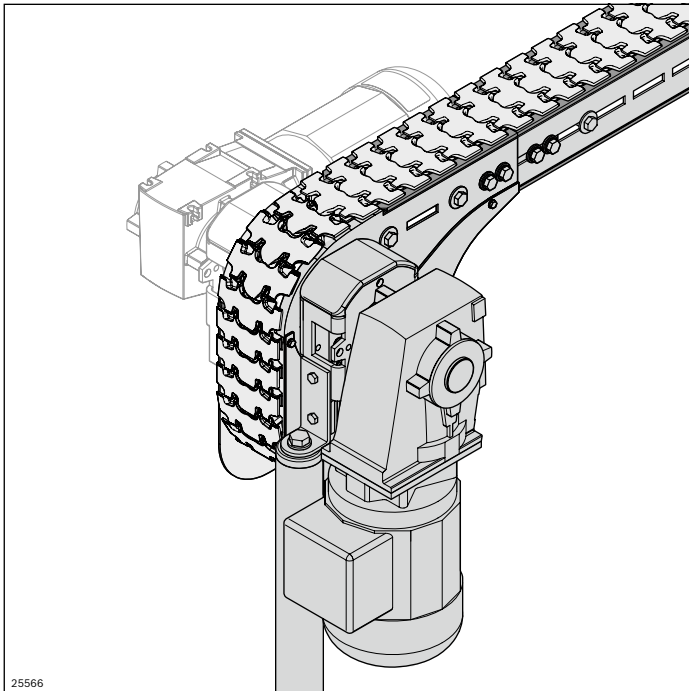





## Drive and return unit STS



- ▶ Basic units with interfaces on both sides for drive kit and transmission (active bridge)
- ▶ Free selection of the motor mounting position on site
- ▶ Configurable drive kit (standard gear motor or round shaft)
- ▶ Multi-track systems with standard components possible
- ▶ Continuous slide rail to reduce noise and wear
- ▶ In-stock, standardized components
- ▶ Side elements with slots for accommodating holders

High flexibility and short delivery times thanks to a novel drive concept

	<b>STS basic unit Head drive direct</b>	<b>146</b>
	<b>STS basic unit Connection drive</b>	<b>148</b>
	<b>Basic unit with center drive</b>	<b>150</b>
	<b>Return unit STS Closed head drive STS</b>	<b>152</b>
	<b>90° return unit</b>	<b>154</b>
	<b>Drive kit</b>	<b>156</b>
	<b>Frequency converter motec 8400</b>	<b>158</b>
	<b>Manual control unit Switch/potentiometer unit</b>	<b>161</b>
	<b>Connection kit active (A) bridge Connection kit passive (B) bridge</b>	<b>162</b>
	<b>Connection kit Synchronous drive, external motor/internal motor</b>	<b>164</b>

## Innovative drive concept

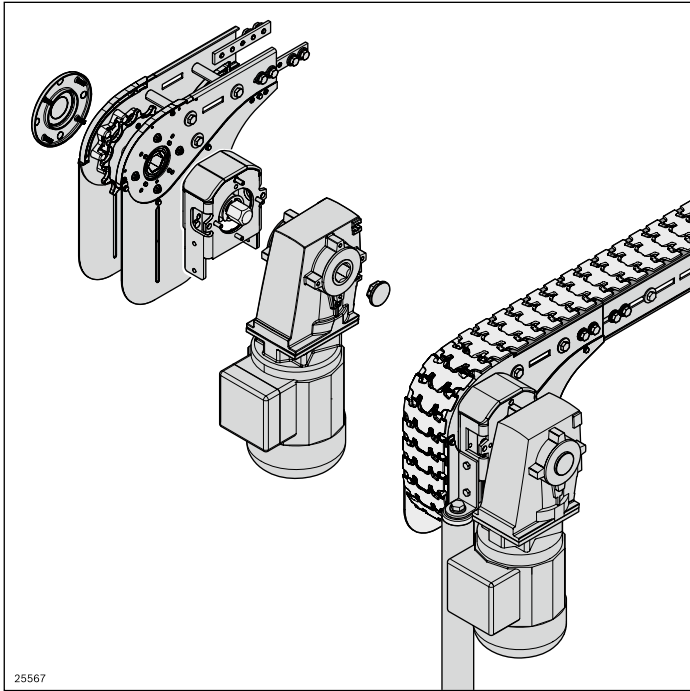

**STS basic unit**  
(head drive direct, center  
or connection drive)

**or return unit**

+

**Configurable drive kit**  
(standard gear motor or round shaft)

=

**complete drive**

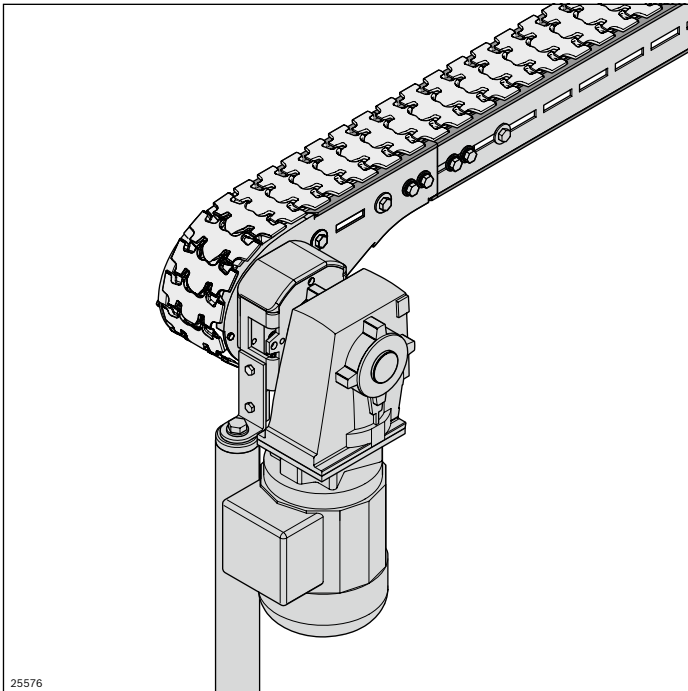

25576

### The well thought-out drive solution enables high flexibility and planning freedom

The in-stock, standardized basic units

- Are quickly and easily combined with the configurable drive kit (standard gear motor or customer-specific interface) into a complete drive
- Guarantee fast availability of the few modular elements/ spare parts

The hollow shaft on both sides in the basic unit and return unit

- Enables a free selection of the motor mounting position on-site
- Offers other interfaces for transmissions (active bridge)

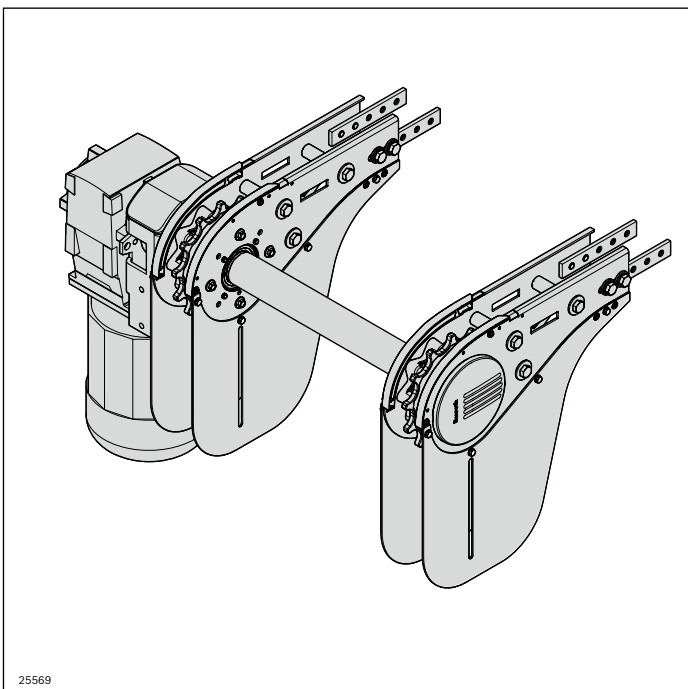

25569

The standard drives are easy to couple and enable straightforward implementation of multi-track systems.

For attachment options, see the matrix on page 289

**Note:** High-pressure cleaning of the ball bearing areas is not permitted.

## STS basic unit Head drive direct

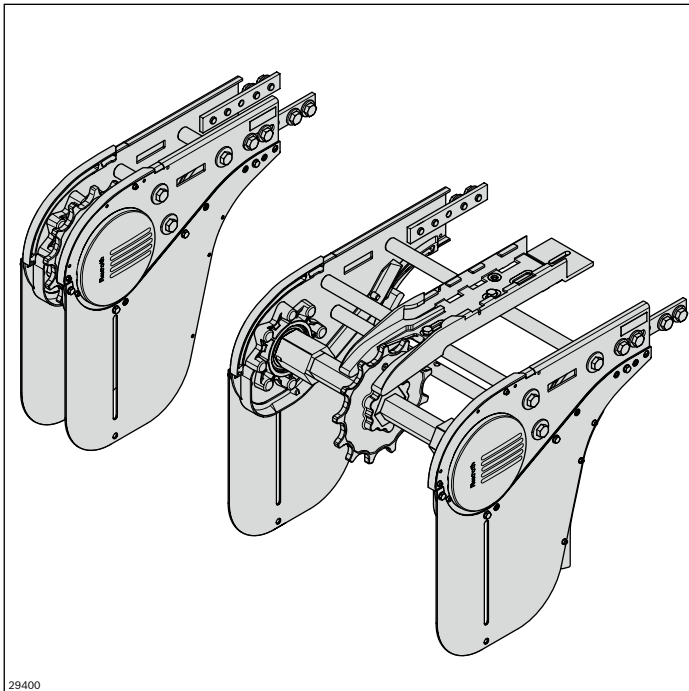

The basic unit is quickly turned into a head drive with variable mounting position by adding a drive kit. With the double-sided hexagonal hollow shaft, other components can be easily driven using a transmission (active bridge).

- Size: all track widths
- Suitable chain types: all
- Permissible chain tensile force:  $F_{max} = 1250 \text{ N}$
- Section length:  $L \leq 30 \text{ m}$
- Conveying speed:  $v_N = 2 \dots 60 \text{ m/min}$ , other speeds available on request
- Chain bag to compensate for chain elongation during service life
- Not suitable for reversible operation

**Note:** A chain sprocket must be used to limit the chain slipping back on inclined sections.

- ▶ Reduced noise emission due to slide rails guided in the head drive
- ▶ Installation of the drive kit possible on the right/left (motor, coupling, flange)
- ▶ Drive of a parallel conveyor section or bridge using a hexagonal hollow shaft integrated as standard

- ▶ Stainless steel ball bearings, with sealing on both sides and FDA-compliant lubrication
- ▶ Side elements with mounting option for attaching holders for lateral guides, or similar

### Required accessories:

- Drive kit, see page 156
- Slide rail: Length calculation, see page 278
- Motor leg sets, see page 169

### Condition on delivery:

- Fully assembled
- Connector and protective chain cover enclosed

### Optional accessories:

- Active or passive bridge connection kits, see page 162
- Synchronous drive connection kit, see page 164
- Chain sprocket for inclined sections, see page 147

### Material:

- Housing: Stainless steel
- Chain wheel: PA
- Chain guide: PA
- Connector: Stainless steel
- Hexagonal shaft
  - up to size 160: PA
  - from size 160: Stainless steel + PA
- Ball bearings: Stainless steel/ FDA

### Scope of delivery:

Incl. fastening material

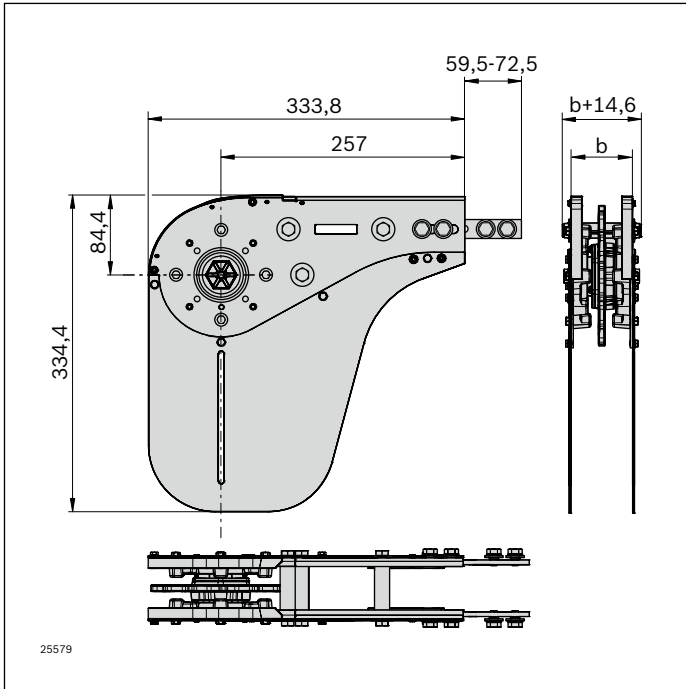

STS basic unit	No.
VFplus 65 direct	3 842 547 522
VFplus 90 direct	3 842 547 523
VFplus 120 direct	3 842 547 524
VFplus 160 direct	3 842 547 525
VFplus 240 direct	3 842 547 526
VFplus 320 direct	3 842 547 527

Order the drive kit in addition to the STS basic unit (see page 156), to complete your drive.

4

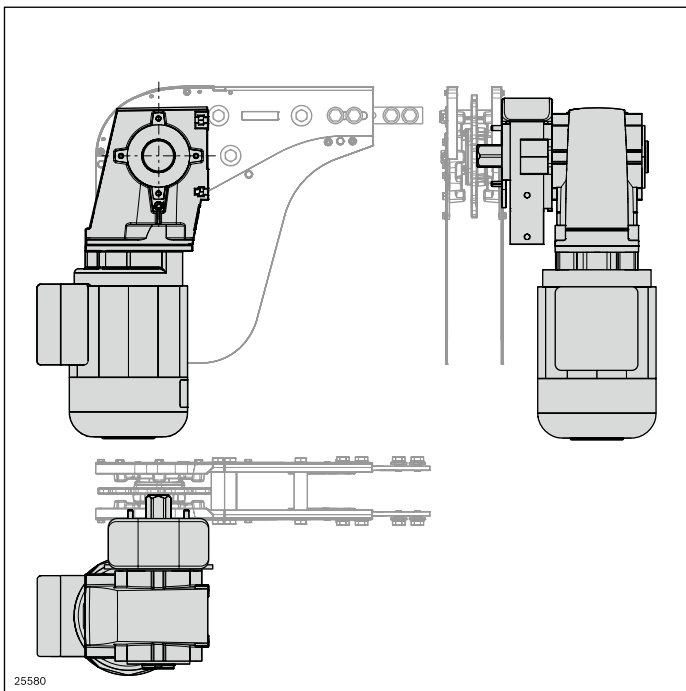

Drive kit VFplus	No.
	3 842 998 291

See page 156

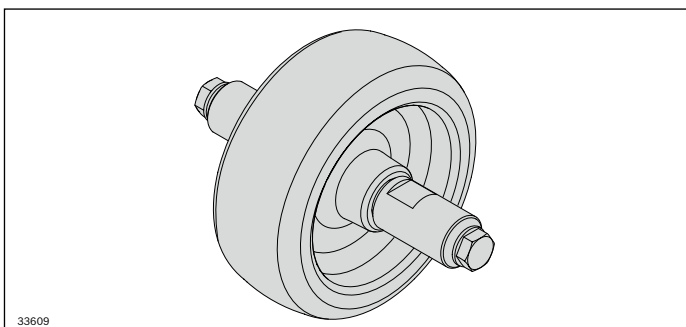

Chain sprocket	No.
VFplus 65	3 842 553 047
VFplus 90	3 842 553 048
VFplus 120	3 842 553 049
VFplus 160	3 842 553 057
VFplus 240	3 842 553 058
VFplus 320	3 842 553 059



## STS basic unit

### Connection drive

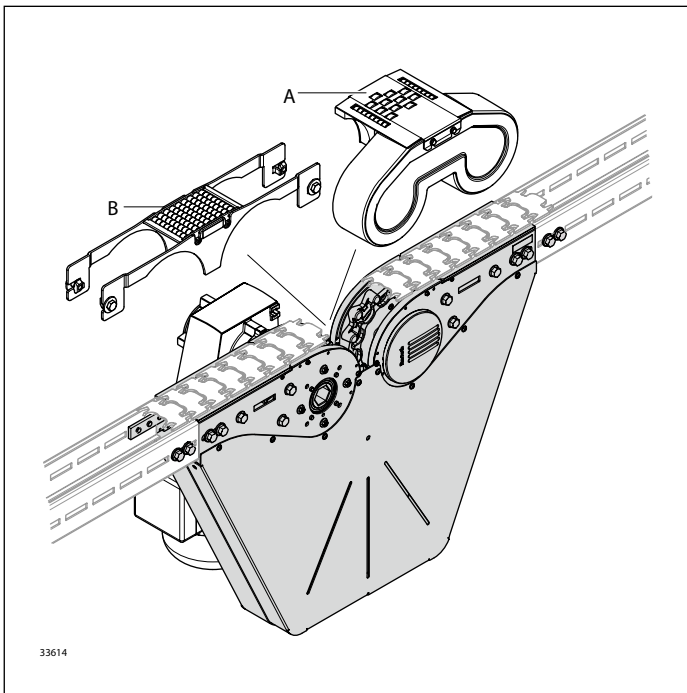

**Note:** The selection of the parameter SP = STS for the drive kit 3 842 998 291 is imperative

- ▶ Reduced noise emission due to slide rails guided in the connection drive
- ▶ Drive kit (motor, coupling, flange) can be mounted right / left
- ▶ Drive of a parallel conveyor section or bridge using a hexagonal hollow shaft integrated as standard
- ▶ Stainless steel ball bearings, with sealing on both sides and FDA-compliant lubrication
- ▶ Side elements with slot for attaching holders for lateral guides, or similar

Required accessories:

- Drive kit, see page 156
- Active bridge **(A)** or passive bridge **(B)**, see page 162
- Slide rail: Length calculation, see page 278

The connection drive is used for driving the conveyor chain in circuit systems with a top-running chain. The basic unit is quickly turned into a connection drive with variable mounting position by adding a drive kit. An active **(A)** or passive **(B)** bridge must be added for transferring the material being transported. The active bridge **(A)** is driven by a transmission from the connection drive

- Size: 65, 90
- Suitable chain types: flat conveyor chain, static friction chain
- Permissible chain tensile force:  $F_{\max} = 1250 \text{ N}$
- Section length:  $L \leq 30 \text{ m}$
- Conveying speed:  $v_N = 2 \dots 25 \text{ m/min}$ , other speeds available on request
- Chain bag to compensate for chain elongation during service life
- Recommendation: No accumulation operation up to 1500 mm after the connection drive
- When using the STS section profile (open) in conveyor systems without a returning chain, a cover must be placed over the lower run by the customer to ensure personal safety.
- Not suitable for reversible operation
- Use in ESD applications with accompanying adapter kit and closed AL section profiles (bridges not conductive!)

Scope of delivery: Incl. fastening material

Condition on delivery: Fully assembled

Material:

- Housing: Stainless steel
- Sprocket, chain guide, hexagonal shaft: PA
- Connector + chain fender: Non-rusting steel 1.4301
- Ball bearings: Stainless steel/ FDA

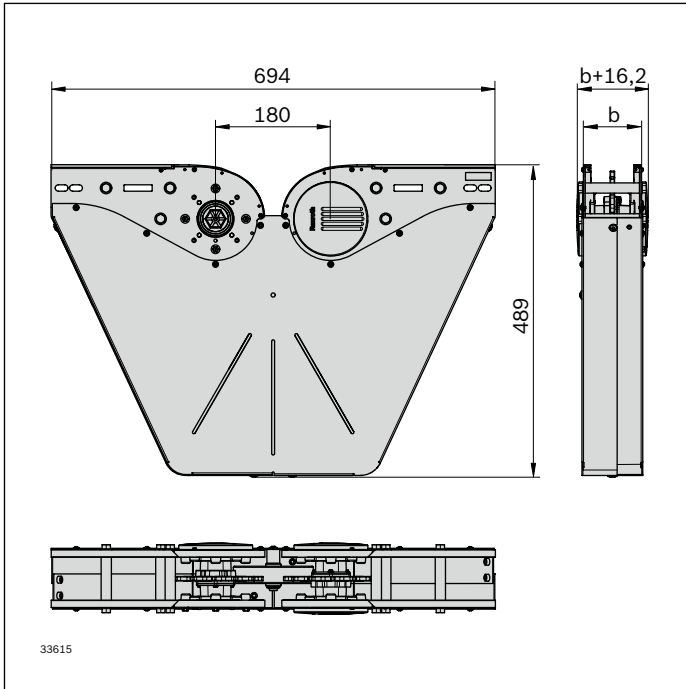

Basic unit connection drive STS	No.
VFplus 65 direct	<b>3 842 553 914</b>
VFplus 90 direct	<b>3 842 553 915</b>

**Note:** When using the section profile STS Clean with the basic units (head drive, return unit, connection drive) the enclosed profile connector (H = 20 mm) must be replaced with the profile connector STS Clean section (H = 17 mm) 3 842 552 927.

4

Drive kit VFplus	No.
	<b>3 842 998 291</b>

SP = STS; See page 156

Connection kit active bridge	No.
VFplus 65	<b>3 842 555 820</b>
VFplus 90	<b>3 842 555 821</b>

See page 162

Passive bridge connection kit	No.
VFplus 65	<b>3 842 549 015</b>
VFplus 90	<b>3 842 549 016</b>

See page 162

## Basic unit with center drive

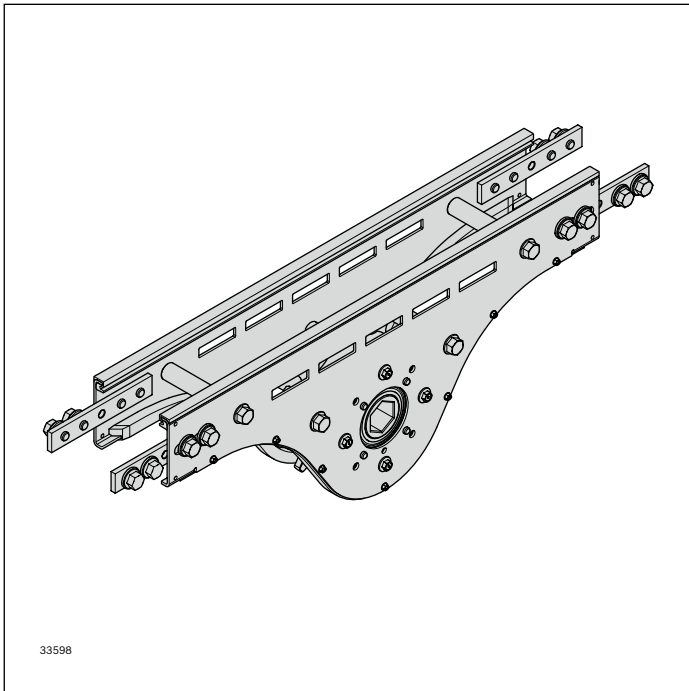

The center drive basic unit is used if the available space is limited at the ends of the sections.

It is quickly turned into a center drive with variable motor mounting position by adding the drive kit

- Size: 65-120
- Chain return on the underside of the profile
- Conveying speed:  $v_N = 2 \dots 60$  m/min, other speeds available on request
- Permissible chain tensile force:  $F_{max} = 600$  N
- Max. conveying length: 7 m
- Because no length compensation (chain bag) is present, the chain length must be checked regularly and shortened if necessary
- Recommendation: No accumulation up to 1000 mm after the return unit
- An assembly module is required for assembling the chain

- ▶ Reduced noise emission due to slide rails guided in the center drive
- ▶ Installation of the drive kit possible on the right/left (motor, coupling, flange)
- ▶ Drive of a parallel conveyor section using a hexagonal hollow shaft integrated as standard

- ▶ Stainless steel ball bearings, with sealing on both sides and FDA-compliant lubrication
- ▶ Side elements with slot for attaching holders for lateral guides, or similar

### Required accessories:

- Drive kit, see page 151
- Slide rail, see page 128
- Motor leg sets, see page 169
- Assembly module, see page 133

### Optional accessories:

- Synchronous drive connection kit, see page 164
- Frequency converter, see page 158

### Scope of delivery:

Incl. fastening material

### Condition on delivery:

Assembled, (profile connector enclosed)

### Material:

- Housing: Stainless steel
- Chain wheel: PA
- Chain guide: PA
- Connector: Stainless steel
- Hexagonal shaft: PA
- Ball bearings: Stainless steel/ FDA

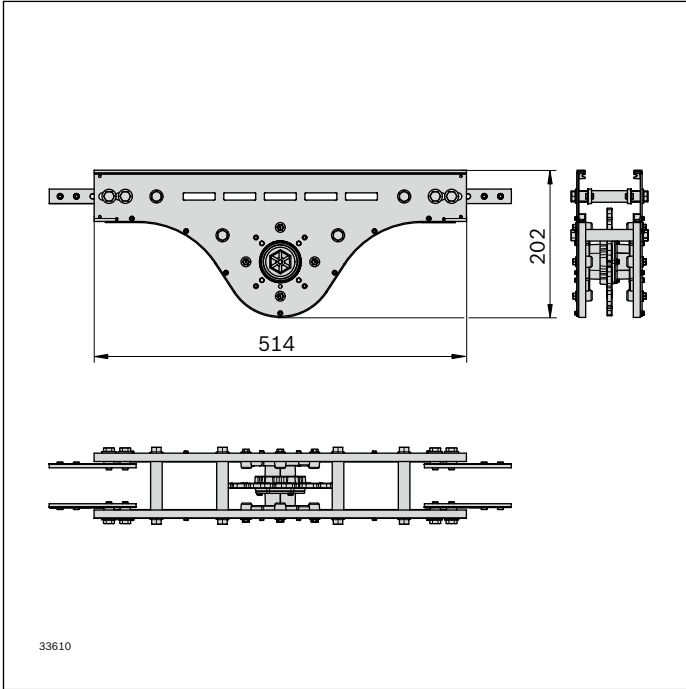

<b>Basic unit with center drive</b>	<b>No.</b>
<i>VFplus 65</i>	<b>3 842 552 940</b>
<i>VFplus 90</i>	<b>3 842 552 941</b>
<i>VFplus 120</i>	<b>3 842 552 942</b>

4

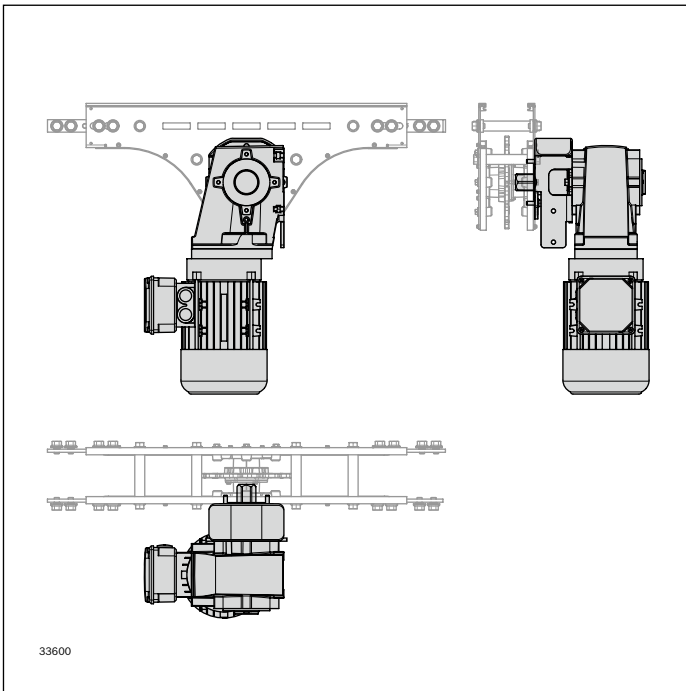

<b>Drive kit <i>VFplus</i></b>	<b>No.</b>
<i>VFplus 65</i>	<b>3 842 998 291</b>

See page 156

## Return unit STS

### Closed head drive STS

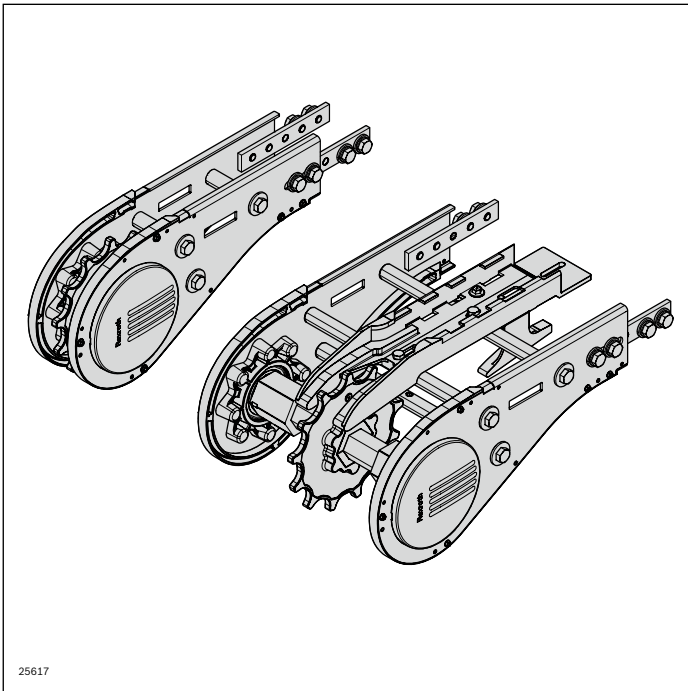

Thanks to the innovative drive concept, the return unit can be operated simply by itself or supplemented with a drive kit to be operated as a head drive without chain bag.

The section length is limited to a maximum of 7 m.

- Size: all track widths
- Suitable chain types: all
- Permissible chain tensile force  
Return unit function:  $F_{max} = 1250 \text{ N}$   
Head drive without chain bag function:  $F_{max} = 600 \text{ N}$   
With shortened maintenance interval, due to chain elongation
- Section length for return unit function:  $L \leq 30 \text{ m}$   
Section length for function as drive:  $L \leq 7 \text{ m}$
- Conveying speed:  $v_N = 2 \dots 60 \text{ m/min}$ , other speeds available on request
- Use as a drive for wedge conveyors, when combined with a drive kit
- Not suitable for reversible operation

- ▶ Reduced noise emission due to slide rails guided in the return unit
- ▶ Installation of the drive kit possible on the right/left (motor, coupling, flange)
- ▶ Drive of a parallel conveyor section or bridge using a hexagonal hollow shaft integrated as standard

- ▶ Stainless steel ball bearings, with sealing on both sides and FDA-compliant lubrication
- ▶ Implementation of parallel sections possible through a pluggable shaft
- ▶ Side elements with mounting option for attaching holders for lateral guides, or similar

#### Required accessories:

- Slide rail: Length calculation, see page 278

#### For use as a drive:

- Assembly module, see page 133
- Drive kit, see page 156
- Motor leg sets, see page 169

#### Scope of delivery:

Incl. fastening material

#### Condition on delivery:

Assembled, connector enclosed

#### Material:

- Housing: Stainless steel
- Chain wheel: PA
- Chain guide: PA
- Connector: Stainless steel
- Hexagonal shaft  
up to size 160: PA  
from size 160: Stainless steel + PA
- Ball bearings: Stainless steel/ FDA

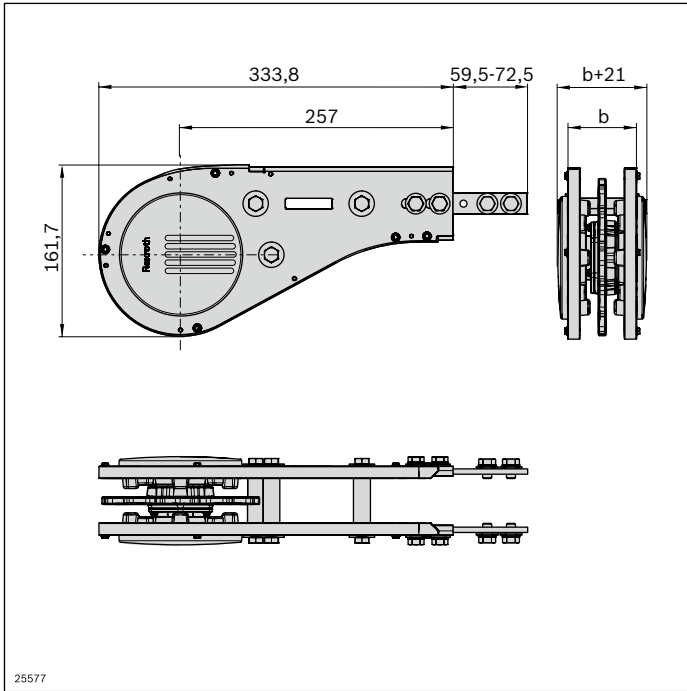

<b>STS return unit</b>	<b>No.</b>
VFplus 65	<b>3 842 547 528</b>
VFplus 90	<b>3 842 547 529</b>
VFplus 120	<b>3 842 547 530</b>
VFplus 160	<b>3 842 547 531</b>
VFplus 240	<b>3 842 547 532</b>
VFplus 320	<b>3 842 547 533</b>

## 90° return unit

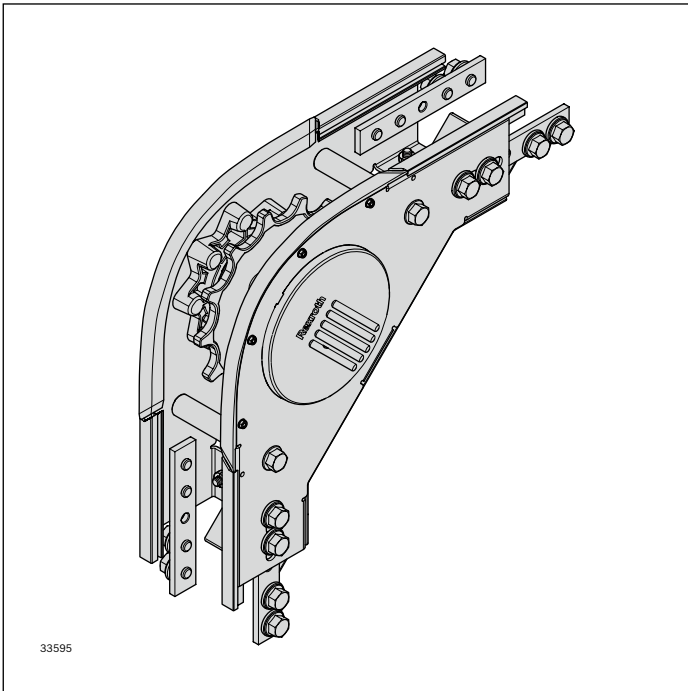

For building alpine conveyors with chain running only on the upper side.

- Only for use with connection drive (AL and STS)
- Size: 65, 90
- Section length:  $L_{\max} = 30$  m

**Note:** When using conveyor systems without a returning chain, a cover must be mounted by the customer to ensure personal safety.

Advantage over alpine conveyor with head drive:

- ▶ shorter chain return, so the required tensile force of the conveyor chain is lower and therefore the possible volume of the alpine conveyor is larger.

- ▶ No longer necessary to mount the slide rails required for the chain return on the bottom side of the profile
- ▶ The required conveyor chain is shorter

Scope of delivery:

Incl. fastening material

Material:

- Housing: Stainless steel
- Chain wheel: PA
- Chain guide: PA
- Connector: Stainless steel
- Hexagonal shaft, PA
- Ball bearings: Stainless steel/ FDA

Condition on delivery:

Fully assembled



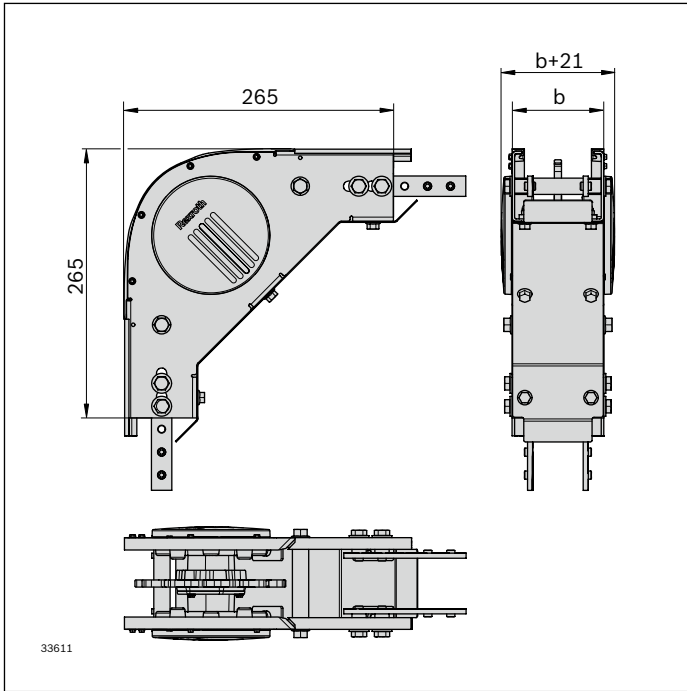

90° return unit	No.
VFplus 65	1 <b>3 842 552 984</b>
VFplus 90	1 <b>3 842 552 985</b>

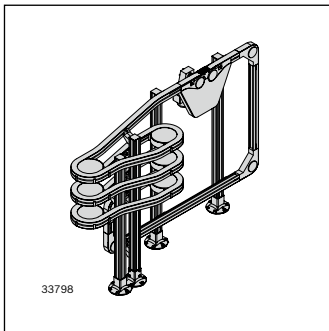

## Drive kit

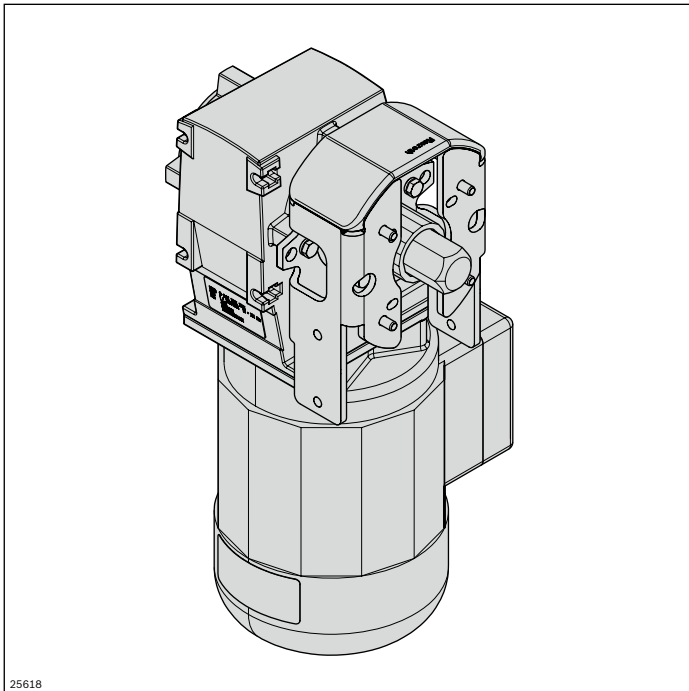

The drive kit is designed to operate the basic head drive unit. It contains a flange for attaching the motor to the basic unit, a hexagonal shaft for transmission of force, as well as other optional equipment features.

- Versions in aluminum (SP = AL) or stainless steel (SP = STS)
- With Lenze gear motor (GM = 1) or with an interface for attaching an SEW SA47 gear motor (GM = 2).  
An adaptation is required by the customer for attaching other gear motors (GM = 0)
- Fixed or adjustable speed ( $v_N$ ). For an adjustable speed, gear motors must be retrofitted with an FU (frequency converter), see page 158
- Different voltages and supply frequencies (U/f)
- Connections are made using terminal boxes (AT = K) or plugs (AT = S)
- GM = 1 without surface and corrosion protection

### Required accessories:

Motor leg sets, see page 168

### Scope of delivery:

- Incl. fastening material
- Incl. flange, shaft and gear motor (GM = 1)

### Material:

- Flange, shaft: Stainless steel
- Motor: Die-cast aluminum
- Cover tube: PE

### Optional accessories:

Frequency converter, see page 158

### Condition on delivery:

Assembly kit

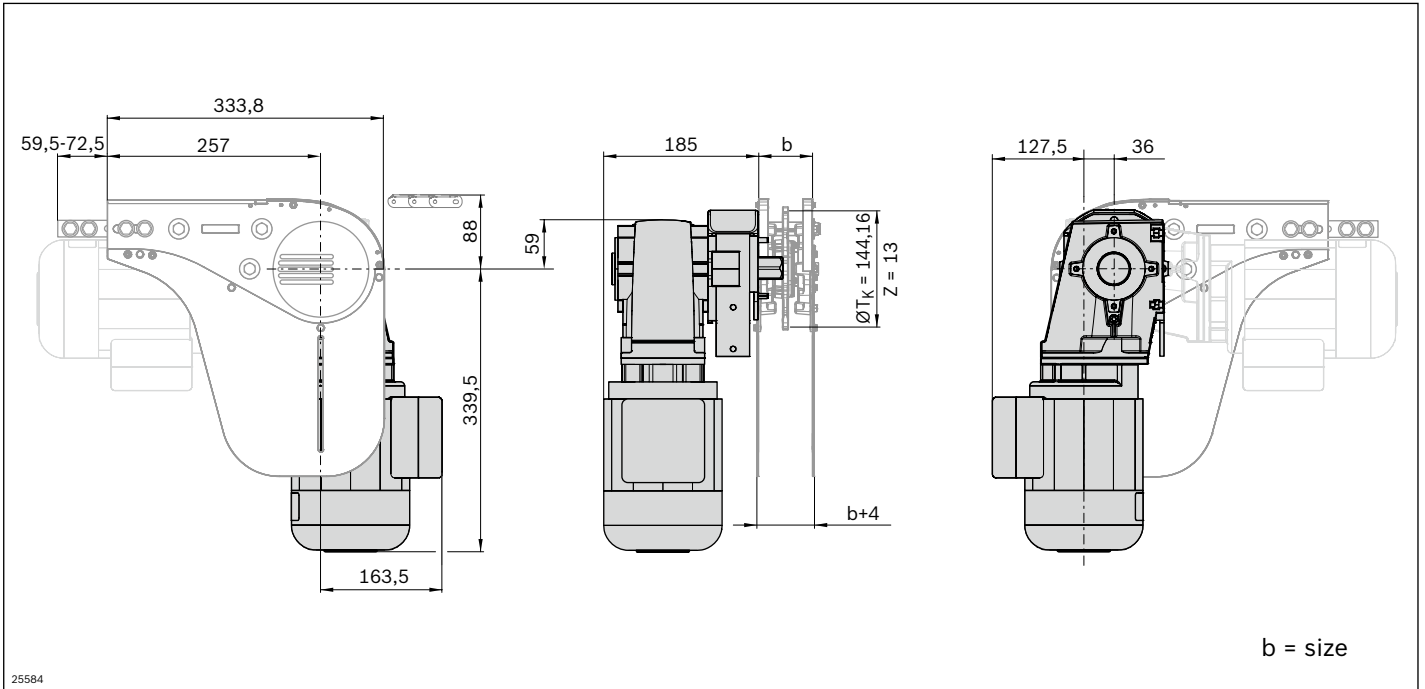

Drive kit VFplus	SP	GM	$v_N$ (m/min)	U/f (V/Hz) See page 281	AT	No.
	STS; AL*	0: 1; 2	5, 10, 13, 16, 21, 27, 33, 40, 50		K; S	<b>3 842 998 291</b> SP = ... GM = ... $v_N$ = ... U/f = ... AT = ...

\* AL version see page 92

STS GM = 0

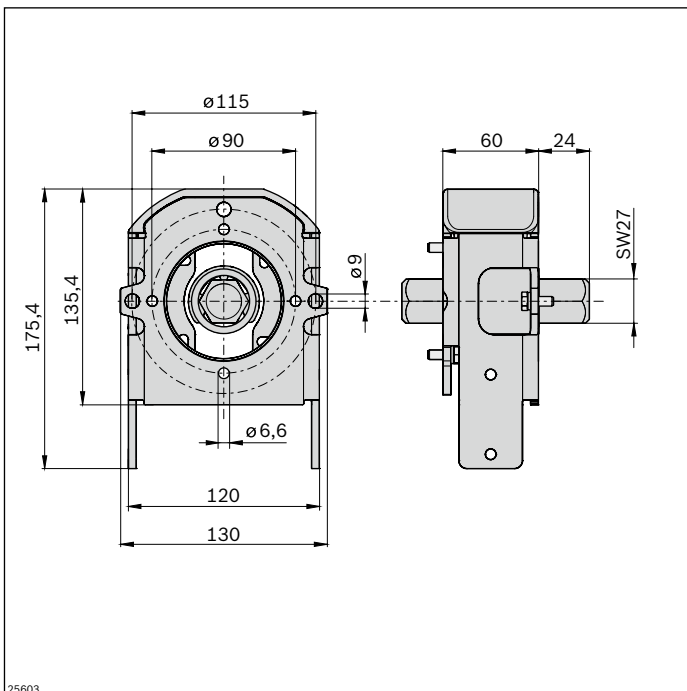

STS GM = 2

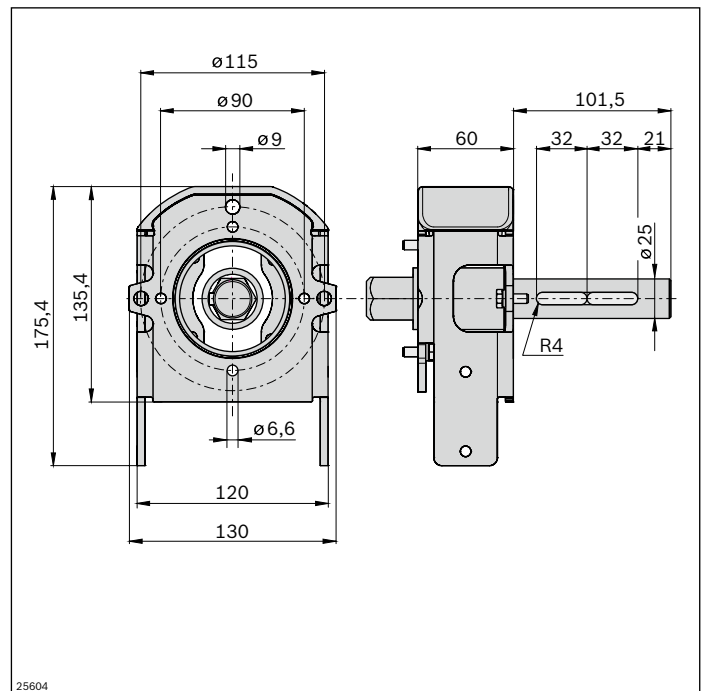

## Frequency converter motec 8400

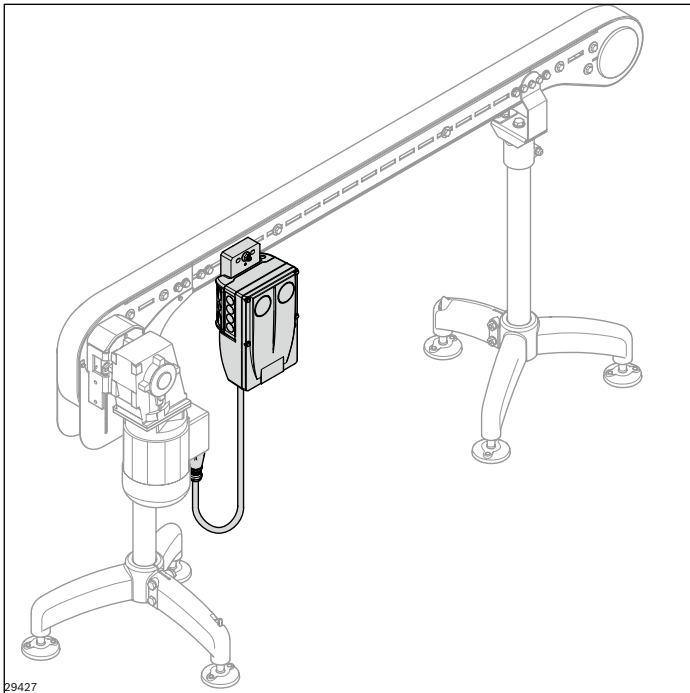

In order to operate a gear motor with adjustable speed, the motor needs to be retrofitted with a frequency converter (FU). The frequency converter has a modular design, whereby it can be easily mounted on a section and connected to the motor by cable.

- Connection power: 0.55 kW (connection voltage: 400 V  $\pm$  10% ... 460 V/480 V  $\pm$  10%)
- Speed ( $v_N$ ) depending on the base speed of the gear motor used

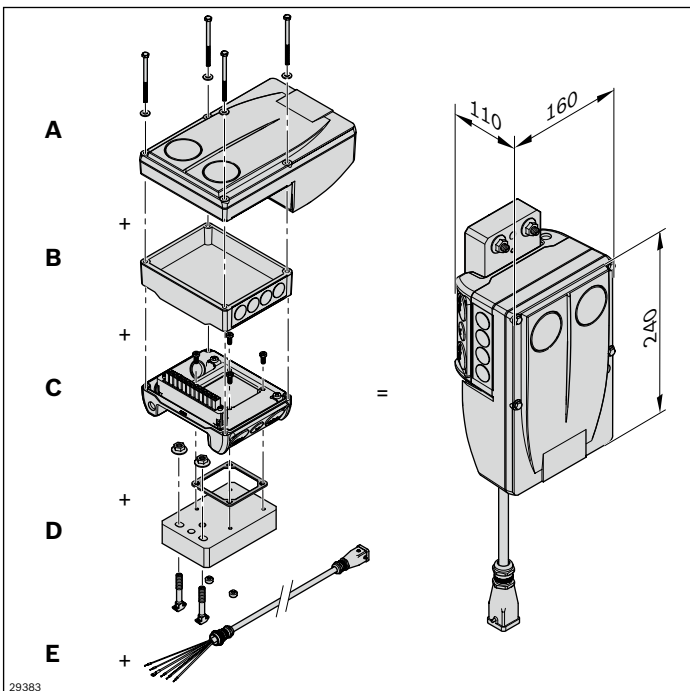

### Complete frequency converter consisting of the modules

- Frequency converter power element (A)
- Communication module (B)
- Connection unit (C)
- Attachment kit (D)
- Optional: Connection cable (E) for the plug-in connection to the gear motor (AT = S)

The individual modules can be ordered separately and are easy to connect with the supplied screws. For the internal and external voltage supply, the modules must be wired by the user (see terminal box assignment, page 285).

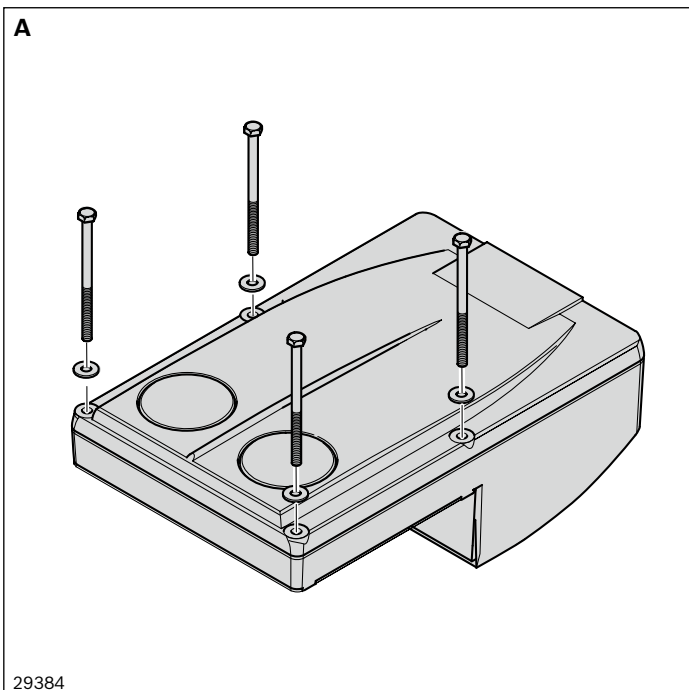

### Frequency converter (A)

Power unit: 0.55 kW

(400 V ± 10% ... 460 V/480 V ± 10%)

- Easy commissioning via hand-held terminal
- Easy to replace memory module
- Large LED as status display

Frequency converter	No.
Power element 0.55 kW	<b>3 842 553 447</b>

The speed range of the frequency converter \*) is based on the base speed of the motor:

Base speed of motor (m/min) at 50 Hz	Min <sup>1)</sup> (m/min)	Max <sup>2)</sup> (m/min)
5 <sup>3)</sup>	2	6
10 <sup>3)</sup>	4	12
13	5	15
16	6	19
21	7	25
27	9	32
33	11	39
40	13	48
50	16	60

\*) By accepting a resulting loss of power, a higher bandwidth can be covered (see page 285)

<sup>1)</sup> Min corresponds to approx. 16 Hz supply frequency

<sup>2)</sup> Max corresponds to approx. 60 Hz supply frequency

<sup>3)</sup> At 460 V/60 Hz max (m/min) 20% higher

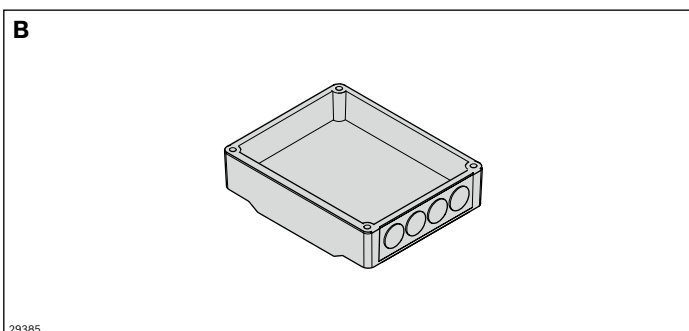

### Communication module (B)

- Used to control the frequency converter
- Cable connection options

Depending on their function, the individual communication modules are provided with the corresponding connections.

Communication module	No.
Standard I/O	<b>3 842 553 449</b>
AS-i	<b>3 842 553 453</b>
CANopen	<b>3 842 553 454</b>
EtherNet/IP	<b>3 842 553 451</b>
EtherCAT	<b>3 842 553 459</b>
PROFIBUS	<b>3 842 553 452</b>
PROFINET	<b>3 842 553 450</b>

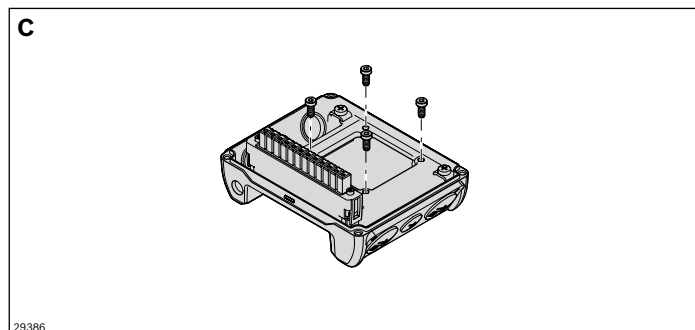

**Connection unit (C)**

- Power grid connection options

Connection unit	No.
	3 842 553 445

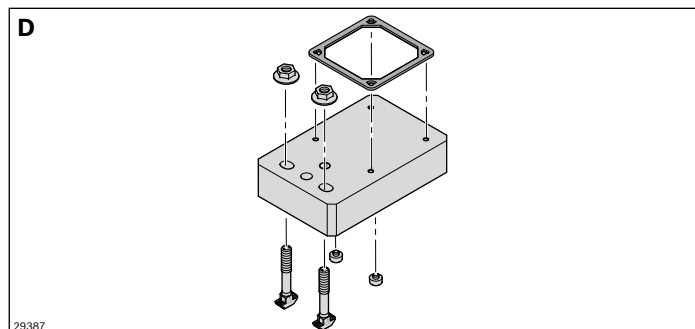

**Attachment kit (D)**

- For the simple attachment of the frequency converter to the STS section

Attachment kit	No.
	3 842 553 457

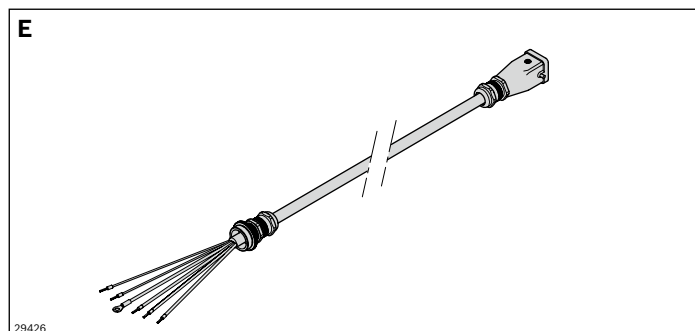

**Connection cable (E)**

- For connecting the gear motor with the frequency converter (length: 1 m)
- For the drive kit AT = S (direct wiring with AT = K)

Connection cable	No.
	3 842 553 512

# Manual control unit

## Switch/potentiometer unit



4

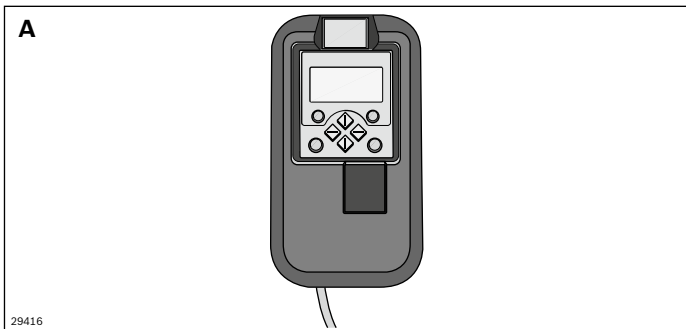

### Manual control unit

The manual control unit is required for the parameterization of drives with frequency converters.

In addition, you can:

- Control (e.g. block and release)
- Display operating data
- Steplessly regulate the transport speed
- Transfer parameter sets to other basic devices

Manual control unit	No.
	3 842 552 821

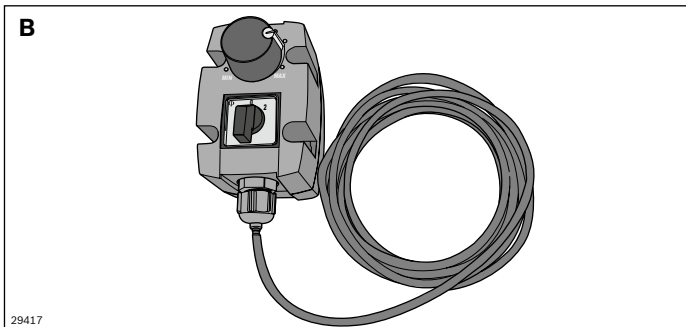

### Switch/potentiometer unit

The switch/potentiometer unit is used to fine tune the transport speed within a range that has been preset with the manual control unit. The switch/potentiometer unit is connected to the frequency converter by a cable. The drive can be started or stopped with the rotary switch.

**Note:** It is imperative that the direction in which the chain conveyor is running is checked prior to commissioning.

Switch/potentiometer unit	No.
	3 842 553 184

Scope of delivery:

**A, B:** Incl. 2.5 m connection cable



## Connection kit active (A) bridge Connection kit passive (B) bridge

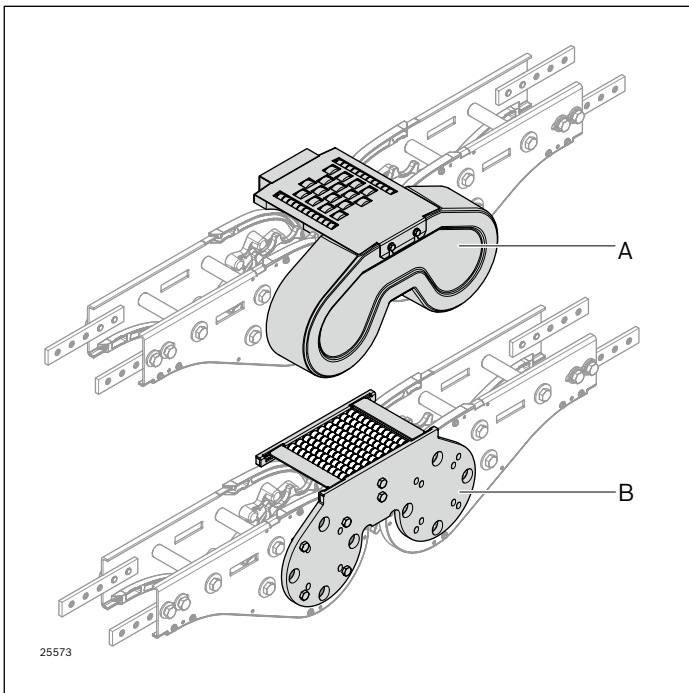

The active and passive bridges are used as a transfer unit between the basic unit and return unit or with the connection drive to bridge the flat conveyor chain.

- Size: 65-160
- Only for flat conveyor chain and static friction chain
- For dimensionally stable products with an even transport surface
- Height adjustment: approx. 3 mm
- Additional versions (e.g. machine variants) available on request

**A:** The active bridge is driven by a transmission (on the drive or return unit side).

- Suitable for conveyed materials from approx. 100 mm in length (depending on the speed, position of the center of gravity, product friction, etc.)
- Freely selectable mounting position (L/R)
- Not permitted for wet operation or rough ambient conditions

**B:** The passive bridge serves to bridge the conveyor trench.

- The conveyed goods are transferred via passive rollers
- Suitable for goods from approx. 300 mm length

► **A:** Simple transmission of the drive force using hexagonal hollow shafts integrated into the basic unit or return unit as standard

► **A+B:** Can be retrofitted into a standard configuration at any time

Scope of delivery:

- **A+B:** Incl. fastening material
- **A:** Transmission and protective cover

Material:

- Active bridge: Stainless steel/PA/POM/ABS/PUR
- Passive bridge: Stainless steel/POM

► **A+B:** Active and passive bridges can be used at section ends for product transfer

Condition on delivery:

Partially assembled

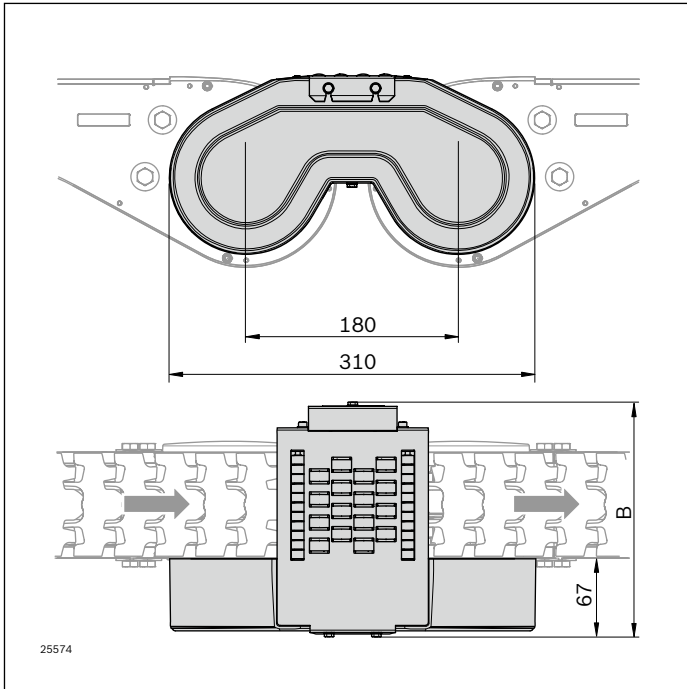

Connection kit active bridge	B	No.
VFplus 65	174	<b>3 842 555 820</b>
VFplus 90	199	<b>3 842 555 821</b>
VFplus 120	229	<b>3 842 555 822</b>
VFplus 160	269	<b>3 842 555 823</b>

4

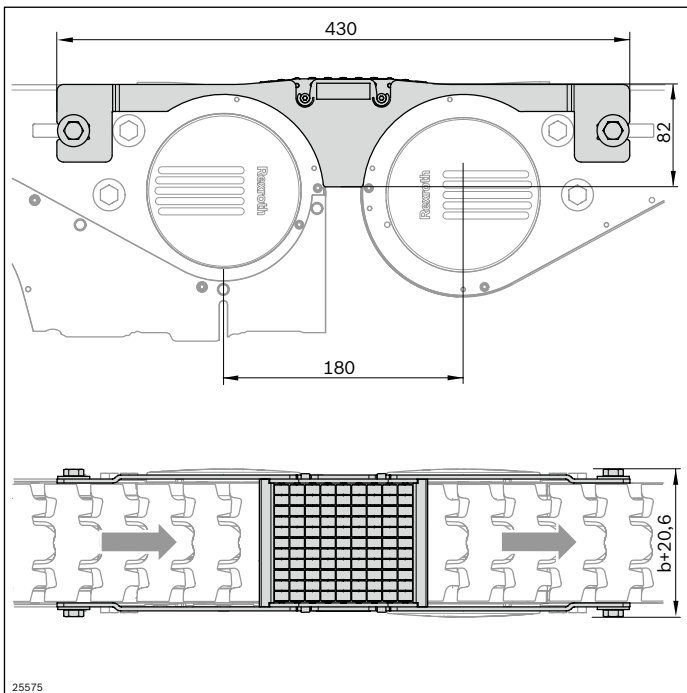

Passive bridge connection kit	No.
VFplus 65	<b>3 842 549 015</b>
VFplus 90	<b>3 842 549 016</b>
VFplus 120	<b>3 842 549 017</b>
VFplus 160	<b>3 842 549 018</b>

## Connection kit

### Synchronous drive, external motor/internal motor

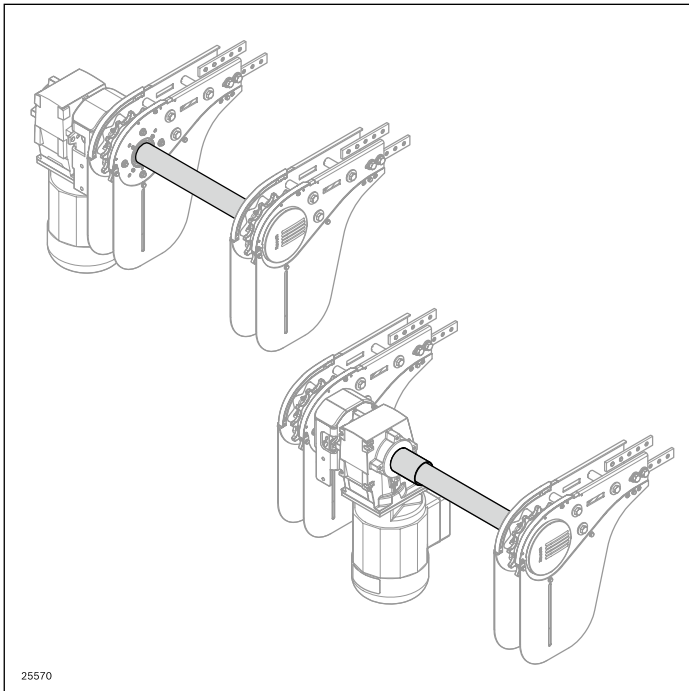

The synchronous drive connection kit is used to synchronously drive two conveyor sections with only one motor.

- External synchronous drive:
  - Motor mounting position outside the parallel sections
- Internal synchronous drive:
  - Motor mounting position between the parallel sections for drive kit GM = 1 (see page 156), customer check required for other motor types

Condition on delivery:  
Not assembled

Material:

- Shaft: Stainless steel
- Coupling: PA

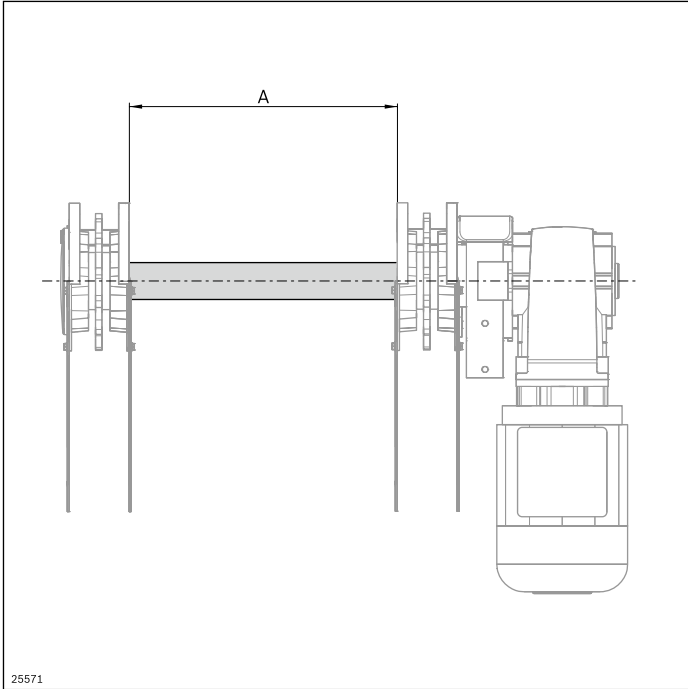

25571

Synchronous drive connection kit	A (mm)	No.
VFplus external motor	15 ... 2940	<b>3 842 998 774</b>

4

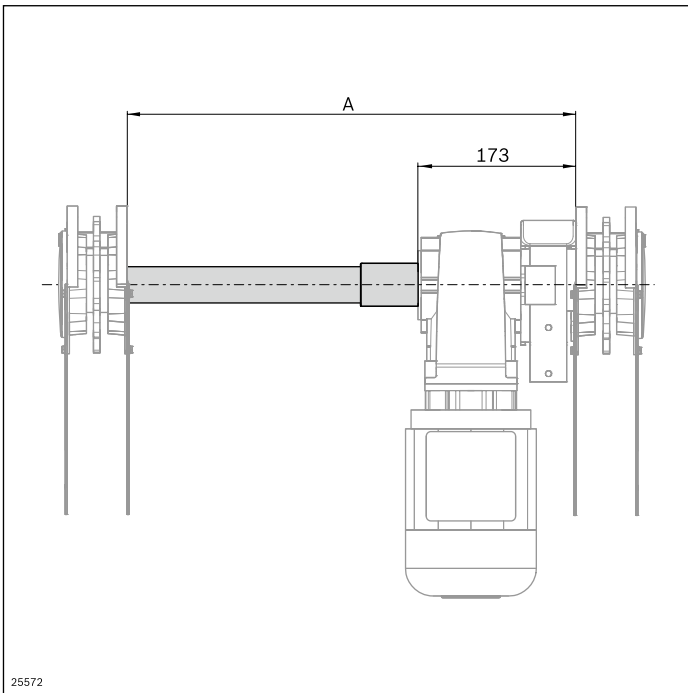

25572

Synchronous drive connection kit	A (mm)	No.
VFplus internal motor	240 ... 3160	<b>3 842 998 775</b>

## STS leg sets

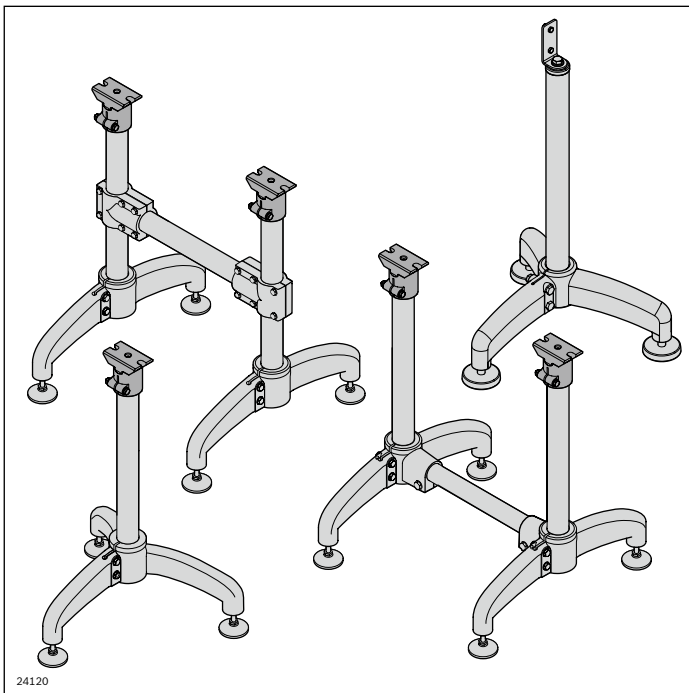

- ▶ Few screwed connections
- ▶ Easy to clean thanks to ample draining surfaces
- ▶ Bore for the easy attachment of drop trays, protective devices, etc.
- ▶ Supports can also be used in conjunction with AL sections

Fast, simple leg set adjustment thanks to clever product details



**STS leg sets**

**168**

## STS leg sets

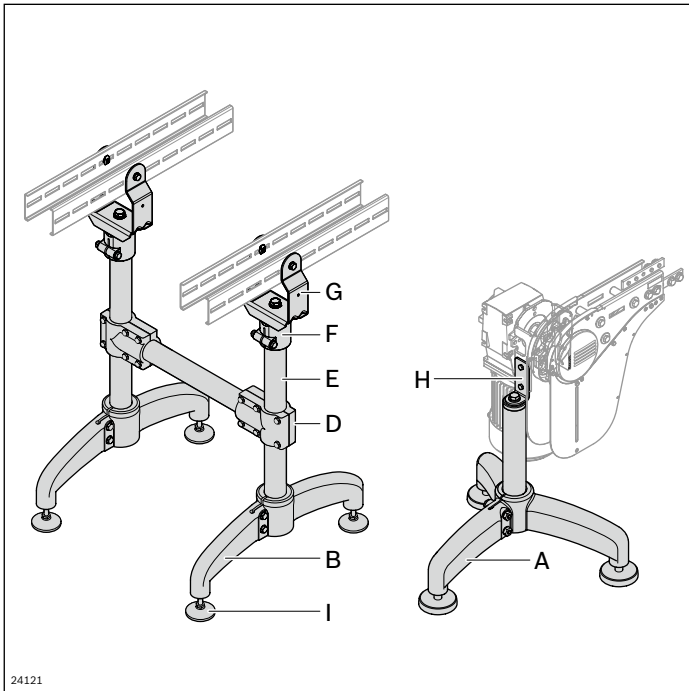

- ▶ For dowelling the leveling feet (I), drill guides are available on the underside
- ▶ Easy-to-clean design with draining surfaces

Scope of delivery:  
Incl. fastening material

Material:

- **A, B, C, D, F:** PA
- **E, G:** Stainless steel
- **H:** Stainless steel with PA
- **I:** STS with PA

The chain conveyor is placed on the ground by means of supports and fastened.

The support is constructed from single parts:

Foot in three different versions (**A, B, C**)

Tube (**E**), flange(**F**) for mounting the holder and holder (**G**) for mounting the section profile.

It is imperative that a separate holder (**H**) is used to support the motors /drives.

- Depending on the speed, accumulation behavior and weight, the supports are to be fixed at a distance of approx. 2 ... 3 m
- The leg sets for the aluminum system (see pages 110, 114) can also be used on the stainless steel system. The holder (**G**) can be connected directly to a strut profile 60x60 and a S12x30-T50 (MGE catalog **3 842 530 236**)
- Holder (**H**) can only be used for the STS system
- Holder (**G**) can also be used for ascending and descending conveyor sections (up to 28°, depending on the return chain)
- Holder (**G**) with drill guide to fasten drip trays, trap guards for return chains, etc., also suitable for section profile 60x60
- Due to stability reasons, cross reinforcements are absolutely necessary when using feet B and C

Condition on delivery:  
Not assembled



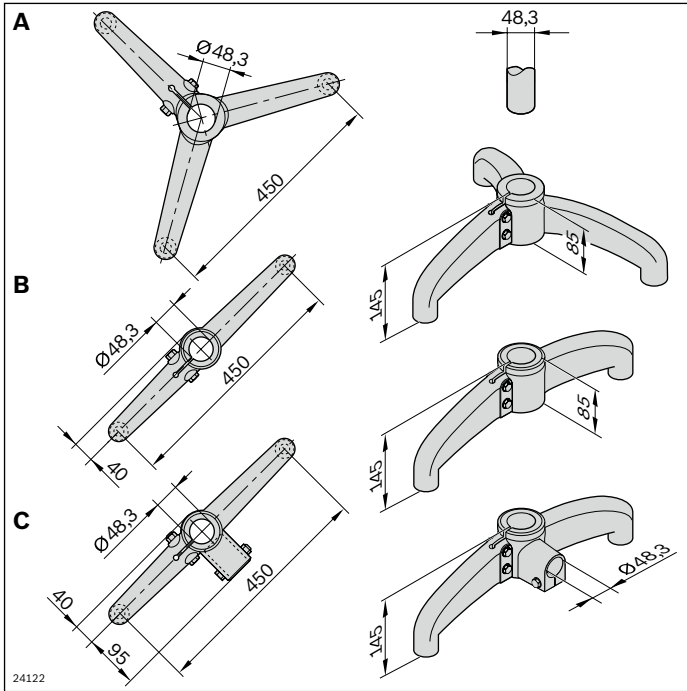

Foot STS	No.
Tripod (A)	1 <b>3 842 533 307</b>
Bipod (B)	1 <b>3 842 533 308</b>
Two-leg with flange (C)	1 <b>3 842 533 309</b>

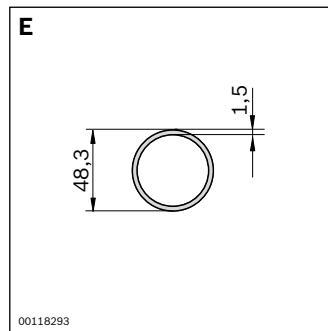
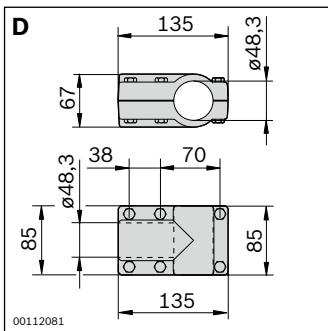

Cross connector (D)	No.
VFplus 80x80, black	1 <b>3 842 533 306</b>

Tube D48.3 x 1.5 STS (E)	L (mm)	No.
6 pcs	3000	<b>3 842 533 901</b>
1 pcs	200 ... 3000	<b>3 842 993 308/L</b>

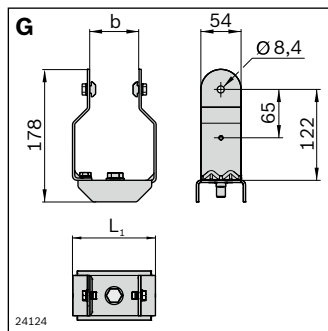
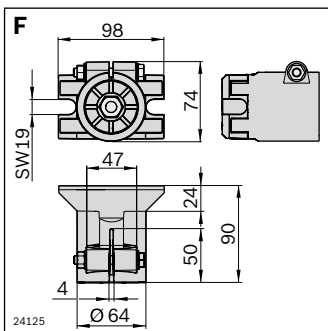

Flange VFplus STS (F)	No.
VFplus support	Set <b>3 842 547 892</b>

Holder STS (G)	b (mm)	L <sub>1</sub> (mm)	No.
VFplus 65 support STS	65	111	Set <b>3 842 546 658</b>
VFplus 90 support STS	90	136	Set <b>3 842 546 659</b>
VFplus 120 support STS	120	166	Set <b>3 842 546 660</b>
VFplus 160 support STS	160	206	Set <b>3 842 546 661</b>
VFplus 240 support STS	240	286	Set <b>3 842 546 662</b>
VFplus 320 support STS	320	366	Set <b>3 842 546 663</b>

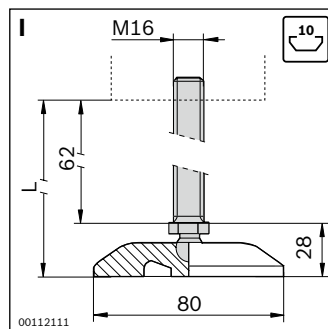
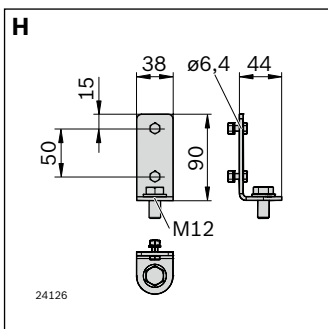

STS motor leg set holder (H)	No.
VFplus	Set <b>3 842 549 365</b>

Leveling foot (I)	No.
Adjustable M16x95	<b>3 842 533 310</b>



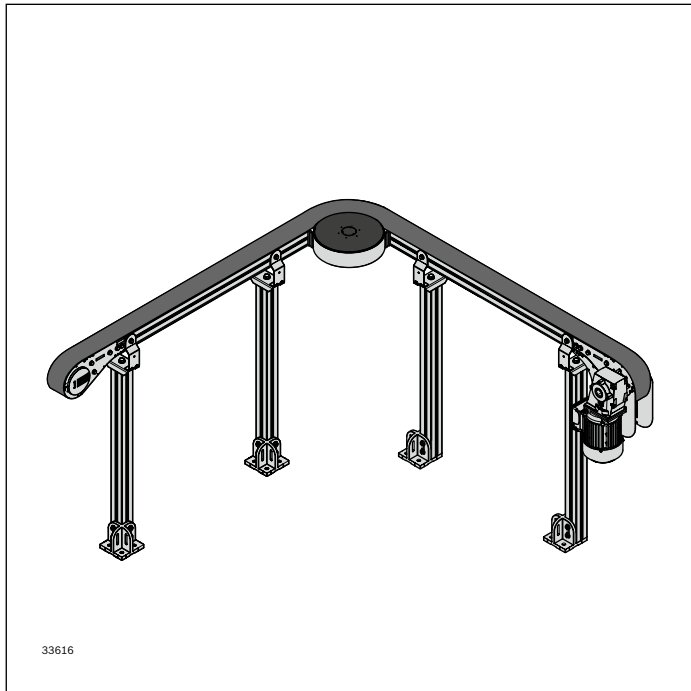





# Vario Flow *plus* ESD system



- ▶ Components and parts suitable for use in an EPA (ESD Protected Area)
- ▶ Conductive components
- ▶ Dissipative connection technology
- ▶ Size: 65, 90
- ▶ Max. speed: 30 m/min
- ▶ Max. chain tensile force: 600 N

**Note:**

Because sliding friction is involved with the transport medium (chain), static charges cannot be completely avoided. Depending on customer requirements, additional measures may be necessary.

	<b>Design of an ESD system</b>	<b>172</b>
	<b>ESD conveyor chain</b>	<b>176</b>
	<b>ESD slide rail</b>	<b>178</b>
	<b>Curve wheel AL ESD</b>	<b>180</b>
	<b>Drive and return unit ESD</b>	<b>182</b>
	<b>AL-STS adapter</b>	<b>184</b>
	<b>ESD leg set</b>	<b>186</b>
	<b>ESD motor leg sets (STS drives on the AL system)</b>	<b>188</b>

## Design of an ESD system

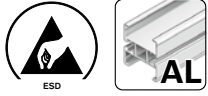

The ESD system comprises a combination of AL, STS and special ESD components.

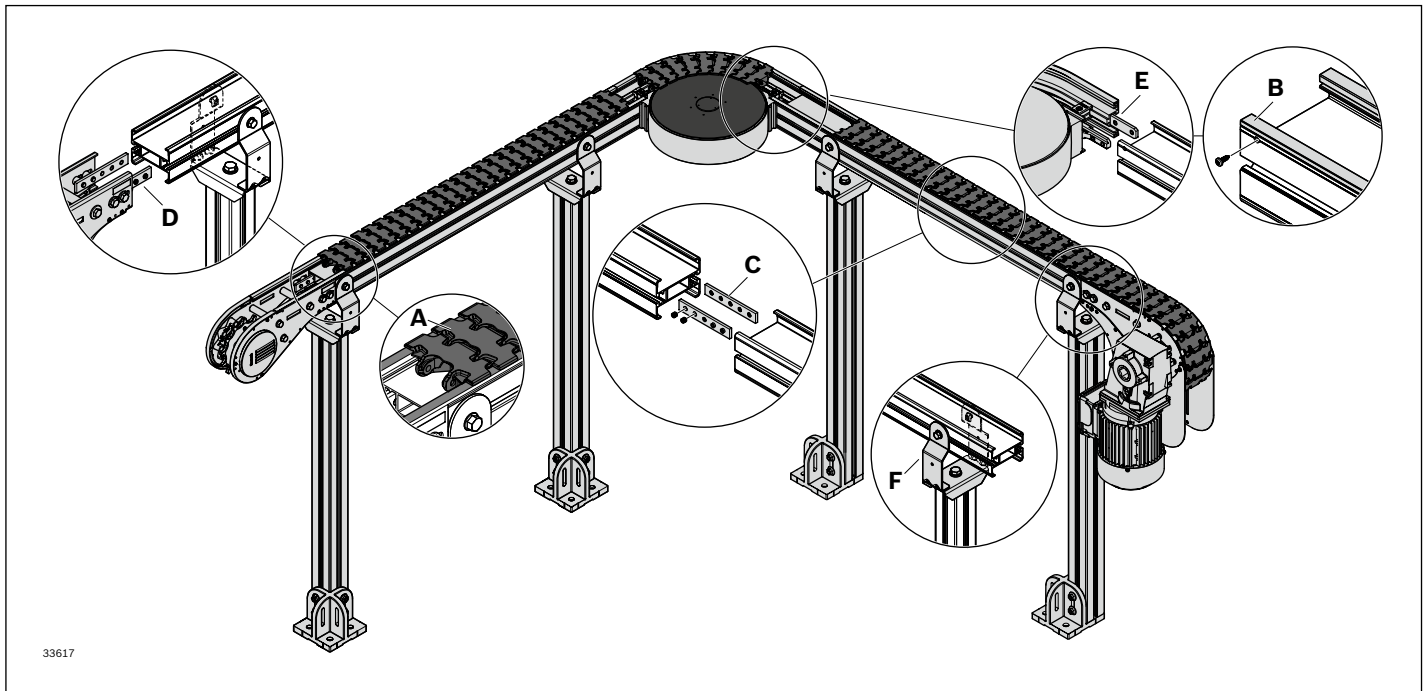

- ▶ **A:** The ESD conveyor chain is deflected to the ESD slide rail via the extensive support.
- ▶ **B:** The ESD slide rail is deflected to the AL section profile (see page 54) via the side standard mount<sup>1)</sup>
- ▶ **C:** The AL section profile is mounted using the AL profile connector<sup>1)</sup>
- ▶ **D:** The STS drive/return unit are mounted on the AL section profile using the AL-STS adapter<sup>1)</sup>. The use of the STS drive/return unit instead of the AL version is necessary to minimize the load creation
- ▶ **E:** The AL ESD curve wheel (see page 180) is screwed with the AL section profile<sup>1)</sup>
- ▶ **F:** The AL leg sets are mounted on the AL section profile via STS holders (screws in the slot)<sup>1)</sup>

<sup>1)</sup> T-bolts, nuts and self-tapping screws break through the anodized layer and form a connection to the conductive aluminum core.

**Note:**

When assembling an ESD system, ensure that all components are conductively connected to each other. Horizontal sliding curves are not suitable for use in EPAs due to the high friction.

In an environment designed for ESD, all components should be made from volume or surface conductive material. Since this is not always possible in the VarioFlow *plus* system for technical and economic reasons, the occurrence of charges (that are strongly dependent on the humidity - 40% minimum should not be fallen short of) cannot be completely excluded for certain components.

No ESD critical processes should be carried out in the vicinity of components such as drives, return units, or bridges. You should move processing-related processes into straight sections and design the complete system according to what your ESD coordinator thinks.

Charges occurring can be discharged through the use of conductive brushes. For machining processes involving particularly sensitive parts, there are numerous components that can be found in Rexroth's Manual Production Systems product range with which individual workstations can be integrated in a VarioFlow *plus* system. These workstations can be implemented, both simply and economically, as completely conductive "islands" according to the ESD requirements.

**Caution:**

Personal safety always comes before ESD safety!

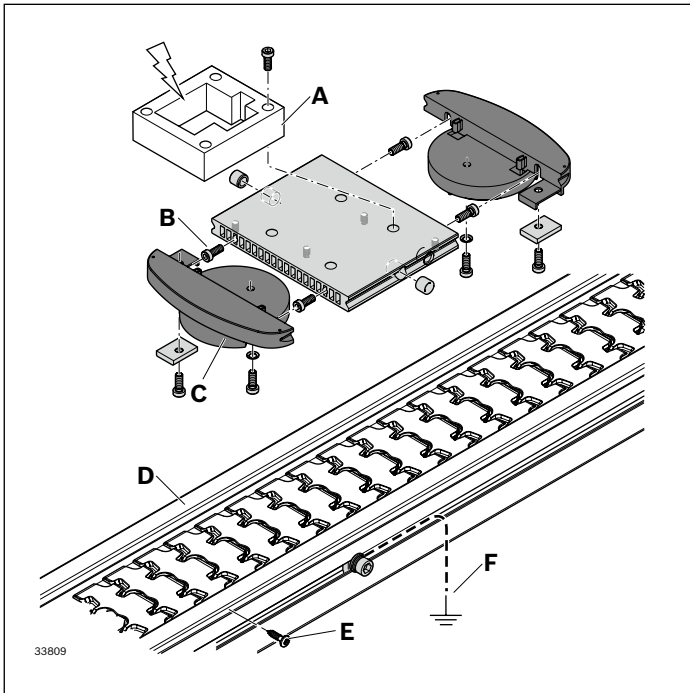

**Workpiece pallet**

- Product carrier connection made of metal or conductive plastic connections to the WT plate via screw (A) (pierced anodized coating)
- Connection to the end caps and the steel sole via screws (B)
- Connection to the conveyor chain via a large contact area (C)
- Connection between the conveyor chain and the slide rail via a large contact area (D)
- Slide rail connection with section profile via screws (E)
- Example connection to the hall potential equalization with a 1 MΩ protective resistor (F)

**Note:**

Only the steel outer sole is ESD capable.

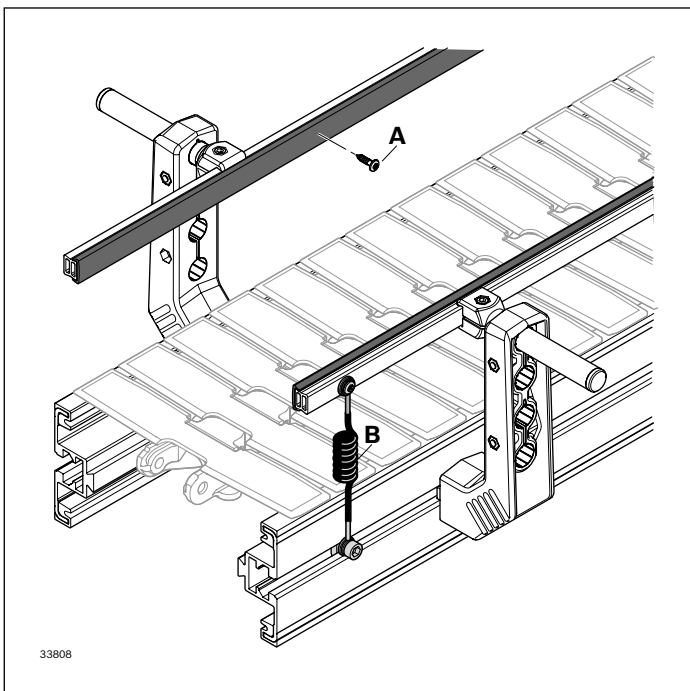

**Lateral guide**

- Slide rail connection narrow with AL profile rail via sheet metal screw (3 842 547 908) (A)
- Connection between AL profile rail - section profile using a screw (3 842 547 908 or 3 842 533 915), cable and T-nut (B) (piercing through the anodized coating and establishing a connection to the conductive aluminum core)

**Note:**

The extension of the AL profile rail is only permitted with the profile connector on the outside (see page 204).



## ESD conveyor chain

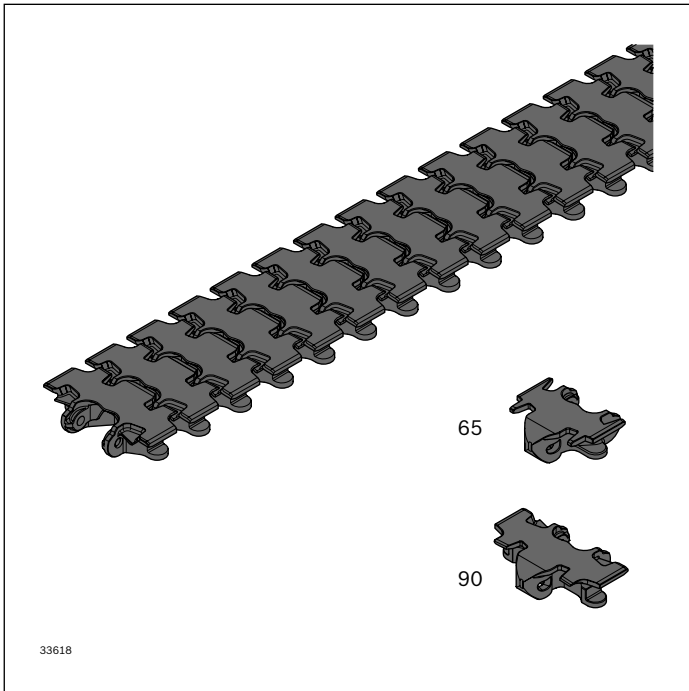

The ESD conveyor chain is used to transport products directly or indirectly via workpiece pallets in electrostatically dissipative systems.

- Transport on ascending or descending sections up to 7° possible, depending on the product (test required)
- Accumulation operation permitted, depending on the product
- Maximum chain tensile force: 600 N
- Conduction resistance:  $< 10^8 \Omega$
- Size: 65, 90
- A combination with other types of chains is not permitted, since these are non-conductive

- ▶ Drilling the flat chain links allows for the simple attachment of superstructures.  
A mold cavity for accommodating a flat M5 hexagon nut/screw.  
Max. drilling up to  $\varnothing 5$  mm since at this point there are no interfering contours in the chain conveyor.

- ▶ Extremely quiet chain running thanks to the patented chain design

Required accessories for individual chain links:  
Chain pin and jointed bolts, see page 177

Scope of delivery:  
Chain: Complete, incl. chain pin and jointed bolts

Condition on delivery:  
Chain: Fully assembled

- Material:
- Chain link: POM; black
  - Chain pin: Stainless steel, 1.4301
  - Jointed bolts: PA66



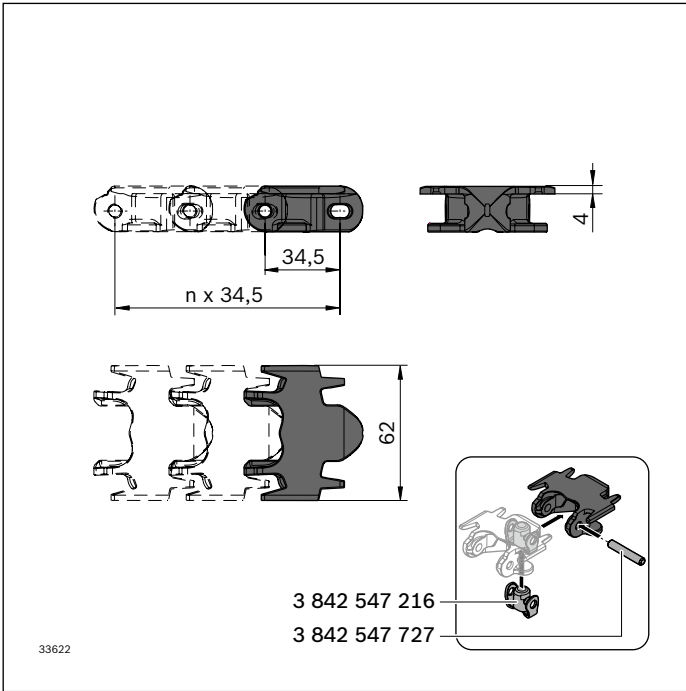

<b>Conveyor chain ESD VFplus 65</b>	<b>L (mm)</b>		<b>No.</b>
Conveyor chain	4968	1	<b>3 842 546 088</b>
Chain pin		100	<b>3 842 547 727</b>
Swivel pin		100	<b>3 842 547 216</b>

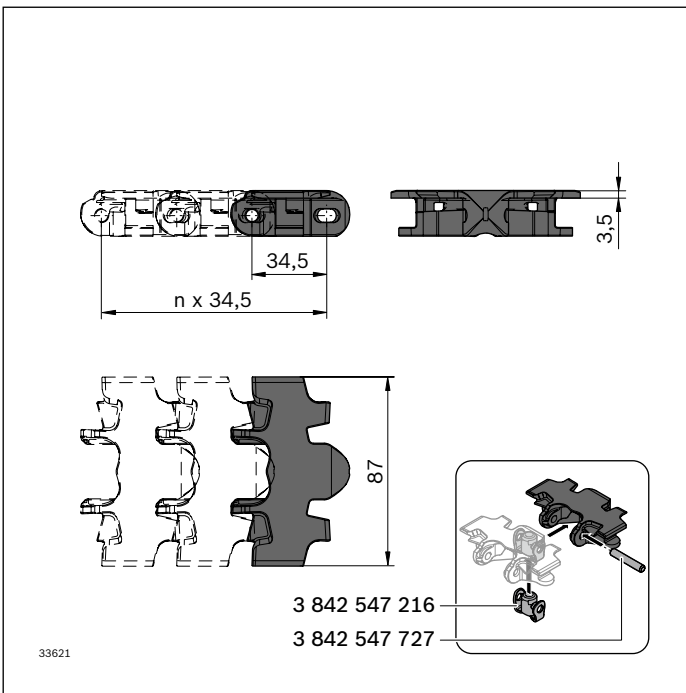

<b>Conveyor chain ESD VFplus 90</b>	<b>L (mm)</b>		<b>No.</b>
Conveyor chain	4968	1	<b>3 842 546 089</b>
Chain pin		100	<b>3 842 547 727</b>
Jointed bolt		100	<b>3 842 547 216</b>

## ESD slide rail

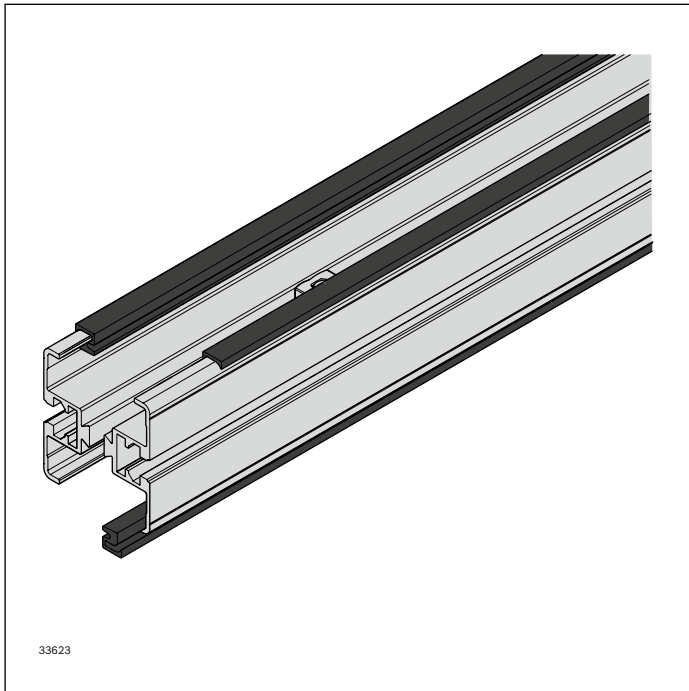

- ▶ Easy assembly - simply clip onto the section profile
- ▶ Secured against axial shifting with lateral screw fittings
- ▶ Gliding surface machining: not required

### Required accessories:

- Slide rail assembly tool, see page 264
- Sheet metal screw 2.9x9.5 DIN 7982; DIN EN ISO 7050 1 screw for each slide rail section

### Material:

PE-UHMW

The ESD slide rail is clipped into the section profile and guides the conveyor chain.

Lateral securing means the gliding surface does not need to be machined. Abrasion and noise levels are thus reduced to a minimum.

The ESD slide rail screwed to the section profile helps to safely discharge loads.

- Size: 65, 90
- Only for AL systems
- $V_{max}$ : 30 m/min
- Conduction resistance:  $< 10^8 \Omega$
- Only suitable for dry operation

Extend the slide rail over the component interfaces to ensure minimum wear and noise emissions.

Interruptions to the profile or component connection must be avoided. If an interruption is necessary after 10 m and to ensure that charges are transferred safely, the slide rail must be attached laterally with a sheet metal screw (**A**).

**Note:** No horizontal sliding curves allowed.

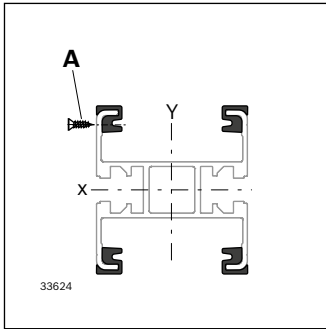

<b>ESD slide rail VFplus</b>	<b>L (mm)</b>		<b>No.</b>
	30000	1	<b>3 842 557 000</b>

<b>Sheet metal screw</b>		<b>No.</b>
<b>A</b>	100	<b>3 842 547 908</b>

## Curve wheel AL ESD

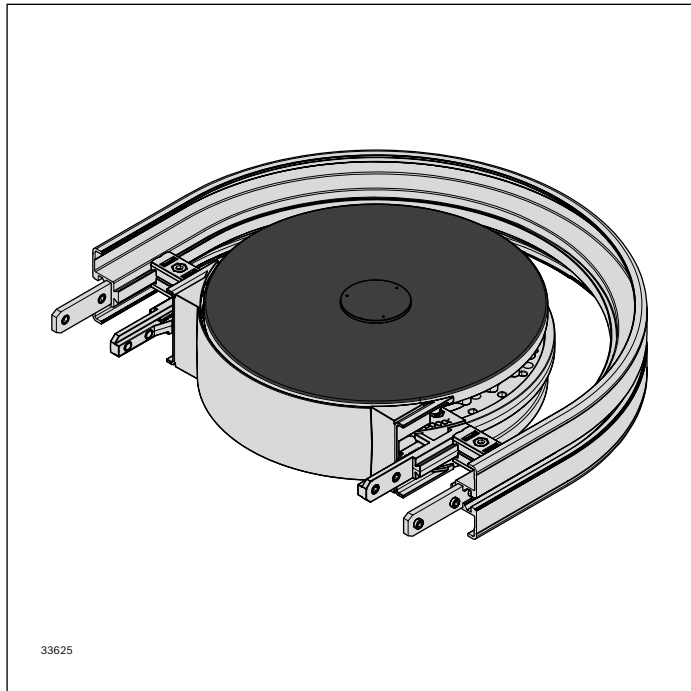
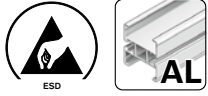

The curve wheel AL ESD provides a horizontal direction change for the conveyor chain. It enables low-friction direction changes with very small radii. For attachment options, see the matrix on page 228

- Size: 65, 90
- Deflection angles see table on page 181, other deflection angles on request
- Suitable chain type: ESD conveyor chain
- For circuit systems without conveyor chain return in bottom run (using a curve wheel or connection drive), the appropriate cover must be used for personal safety reasons
- With conductive wheel

**Note:** High-pressure cleaning of the ball bearings is not permitted.

- No interfering contours above chain plate height

Scope of delivery:

Incl. fastening material for mounting to AL section profiles

Condition on delivery:

Fully assembled

Material:

- Housing: Aluminum, die-cast
- Chain wheel: PA ESD; black
- Ball bearings: Stainless steel/ FDA

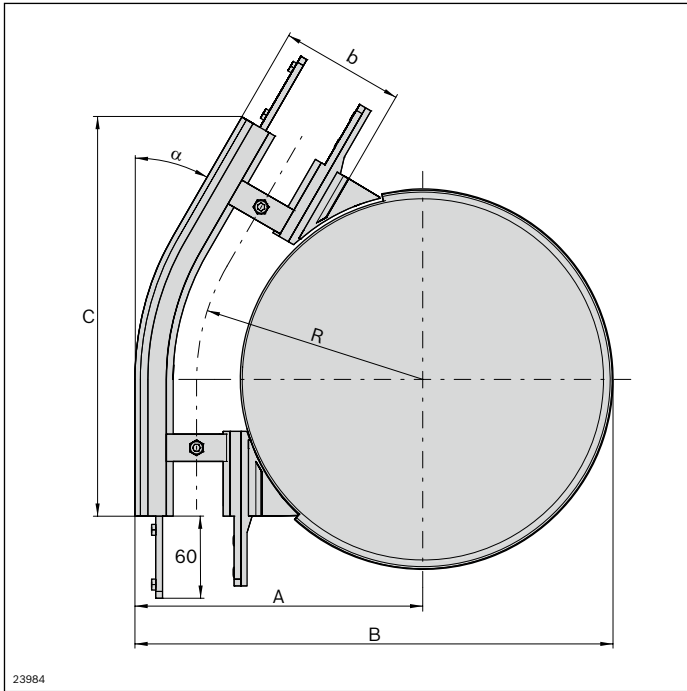

Curve wheel AL ESD	$\alpha$ (°)	No.
VFplus 65	30	<b>3 842 553 029</b>
	45	<b>3 842 553 030</b>
	90	<b>3 842 553 031</b>
	180	<b>3 842 553 032</b>
VFplus 90	30	<b>3 842 553 033</b>
	45	<b>3 842 553 034</b>
	90	<b>3 842 553 035</b>
	180	<b>3 842 553 036</b>

5

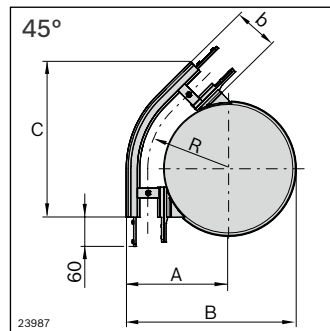
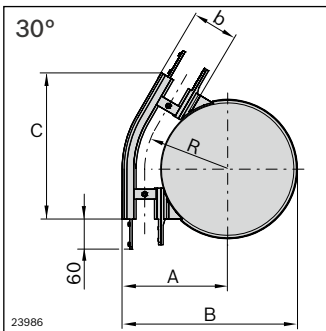

b (mm)	$\alpha$ (°)	R (mm)	A (mm)	B (mm)	C (mm)
65	30	153.0	185.5	324.5	279.4
	45	153.0	185.5	324.5	301.9
	90	153.0	185.5	324.5	285.5
	180	153.0	185.5	-	285.5
90	30	165.5	210.5	349.5	291.9
	45	165.5	210.5	349.5	319.6
	90	165.5	210.5	349.5	310.5
	180	165.5	210.5	-	310.5

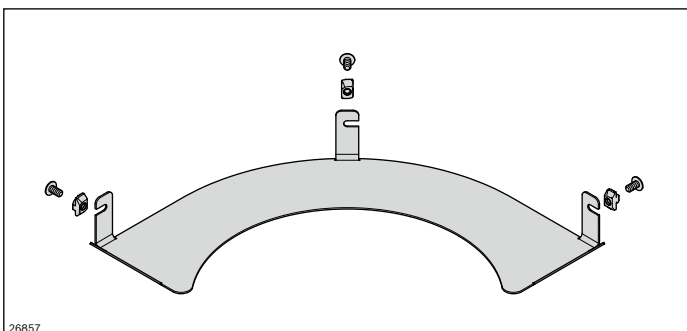
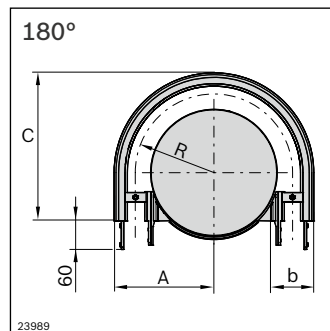
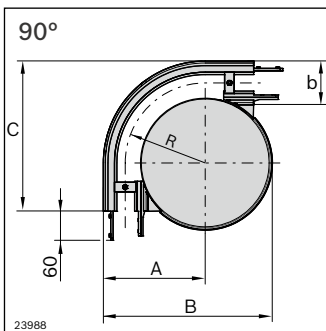

Protective cover AL	$\alpha$ (°)	No.
VFplus 65	30°	<b>3 842 551 545</b>
	45°	<b>3 842 551 546</b>
	90°	<b>3 842 551 547</b>
	180°	<b>3 842 551 548</b>
VFplus 90	30°	<b>3 842 551 549</b>
	45°	<b>3 842 551 550</b>
	90°	<b>3 842 551 551</b>
	180°	<b>3 842 551 552</b>

## Drive and return unit ESD

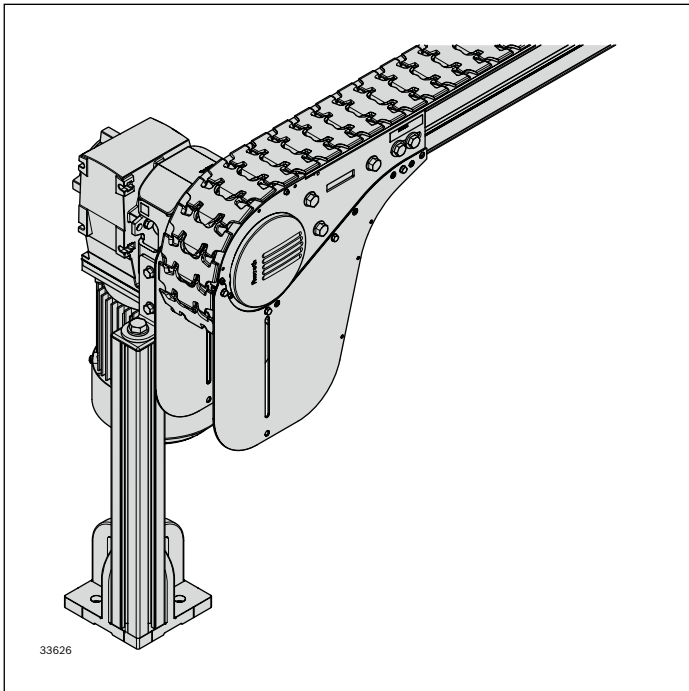

**Base unit STS**  
(head drive direct or center  
or connection drive)  
**or return unit STS**  
+  
**Configurable STS drive kit**  
(standard gear motor or round shaft)  
+  
**AL-STAS adapter**  
=  
**Complete drive for ESD systems**

**Note:** The active and passive bridges are not conductive, meaning that no ESD-critical processes should be carried out near bridges.

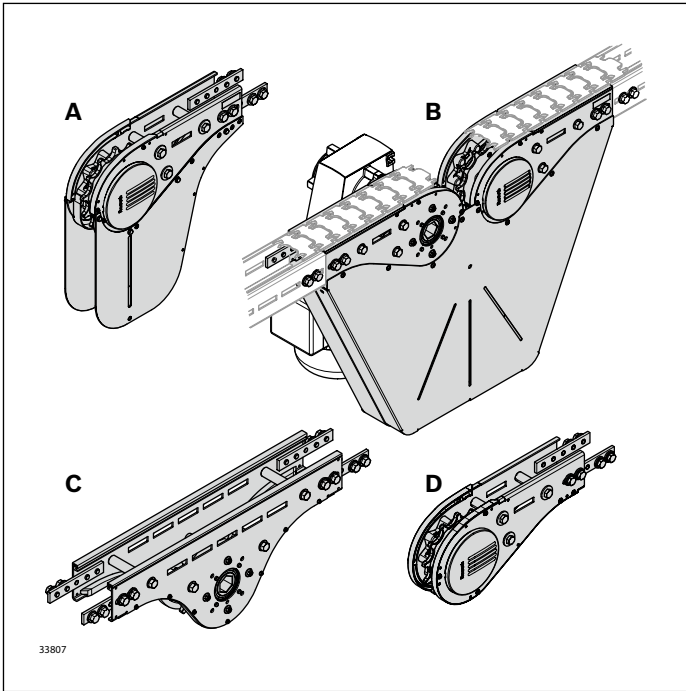

A Basic unit head drive direct, STS	No.
VFplus 65 direct	3 842 547 522
VFplus 90 direct	3 842 547 523
See page 146	

B Basic unit connection drive STS	No.
VFplus 65 direct	3 842 553 914
VFplus 90 direct	3 842 553 915
See page 148	

C Basic unit center drive STS	No.
VFplus 65 direct	3 842 552 940
VFplus 90 direct	3 842 552 941
See page 150	

D STS return unit	No.
VFplus 65	3 842 547 528
VFplus 90	3 842 547 529
See page 152	

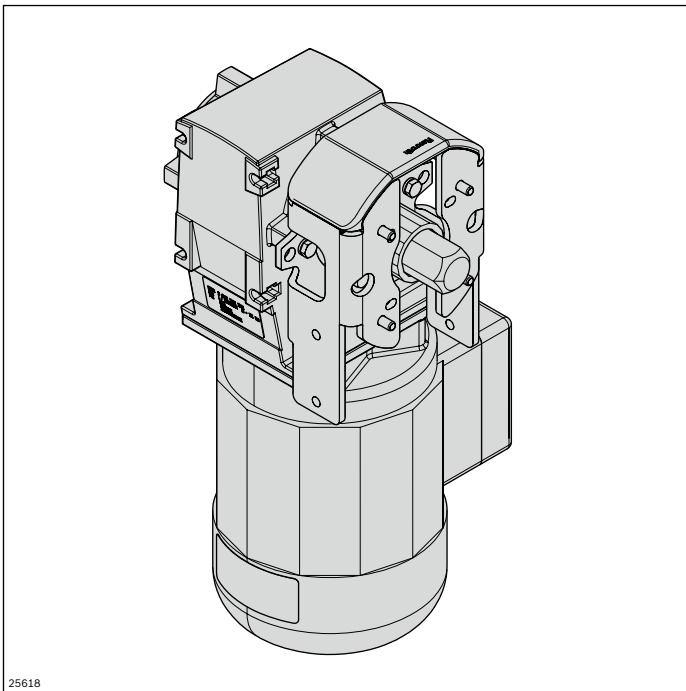

Drive kit VFplus	SP	No.
	STS	3 842 998 291

SP = STS, see page 156

**Note:**

- The drive kit is to be supported with the holder motor leg set STS (3 842 549 365) and an ESD motor leg set
- The selection of the parameter SP = STS is imperative. Even if an aluminum track is used because centering is not possible on an AL flange.

**Required accessories:**

ESD motor leg sets, see page 188

## AL-STS adapter

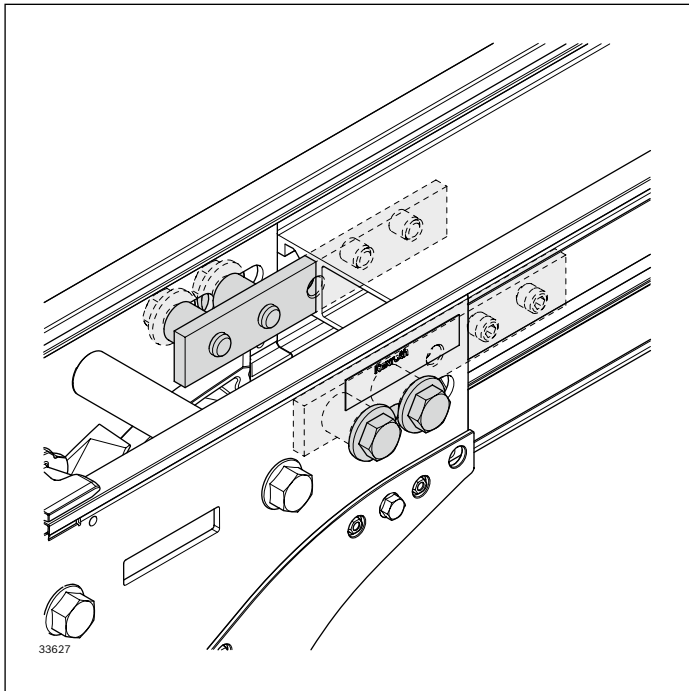
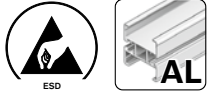

The kit enables the simple connection of the STS basic unit head, connection drive, as well as the return unit with the aluminum system.

When the connection drive is used, the closed AL section profile is to be used for safety reasons.

### Scope of delivery:

- 8x hexagon screws
- 8x headless setscrews
- 8x spacers

(Scope of delivery for 2 Al-STS interfaces, e.g. 1 x basic unit head drive + 1 x return unit OR 1 x connection, or center drive)

### Condition on delivery:

Not assembled

Material: aluminum, steel; galvanized



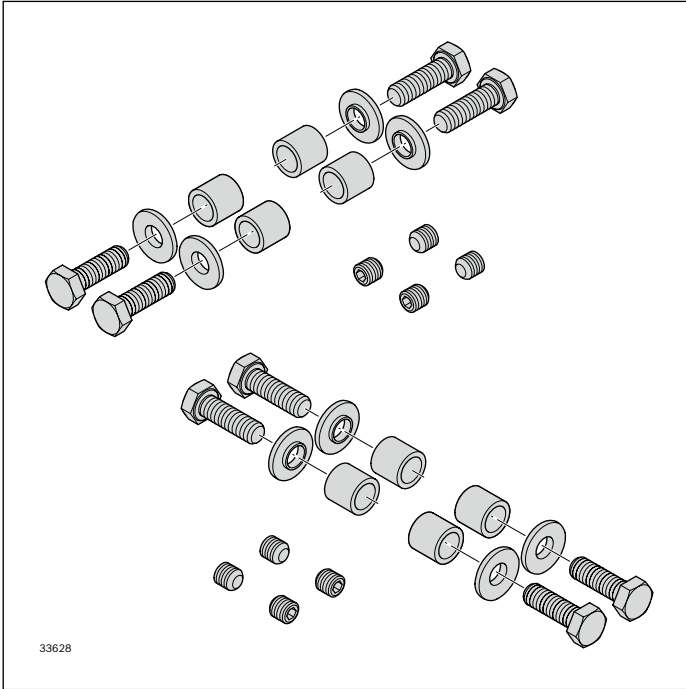

<b>Adapter VFplus AL-STS</b>	<b>No.</b>
	<b>3 842 552 948</b>

## ESD leg set

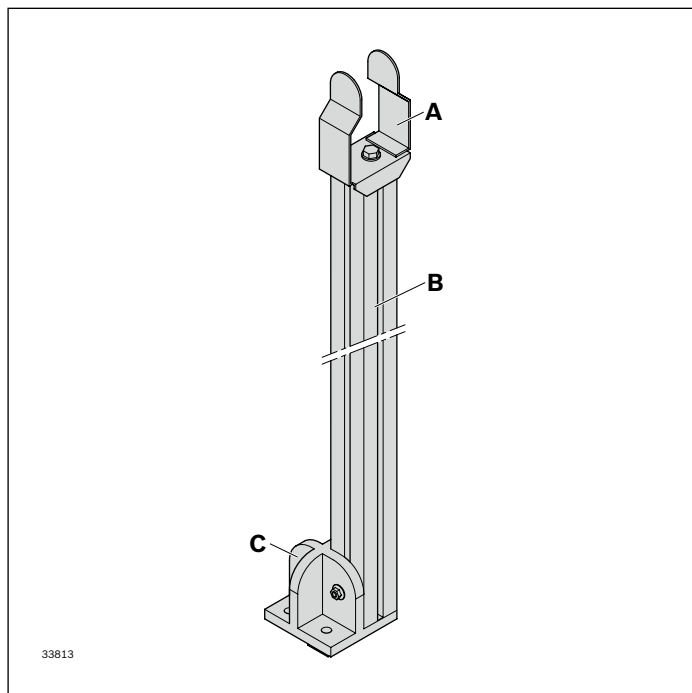

The STS T-nuts included in the scope of delivery of the STS holder (**A**) must be replaced with MGE T-nuts M8. The anodized layer is thereby pierced and connected to the conductive STS holder.

The connection between the STS holder (**A**) and the core pull of the AL strut profile (**B**) is established via the M12 hexagon screw of the STS holder.

Instead of the coated VarioFlow *plus* foot, the 120x120 base plate (**C**) included in the MGE program must be used. The connection of the base plate to the strut profile is done using T-bolts and flange nuts

## Required accessories:

- 4x T-bolts M8x30, 3 842 528 721, see page 63
- 4x flange nuts, 3 842 345 081, see page 63

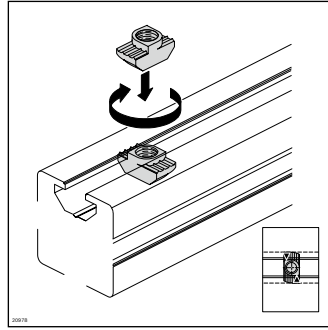
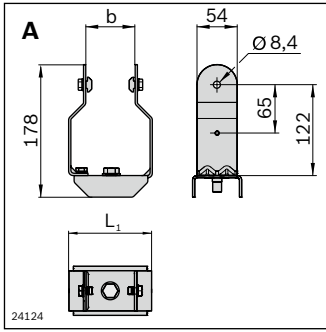

Holder STS	b (mm)	L <sub>1</sub> (mm)	ESD	No.
VFplus 65 support STS	65	111	Set	<b>3 842 546 658</b>
VFplus 90 support STS	90	136	Set	<b>3 842 546 659</b>

T-nut, 10 mm slot	Groove	M	ESD	No.
steel; galvanized	10	M8	100	<b>3 842 530 287</b>

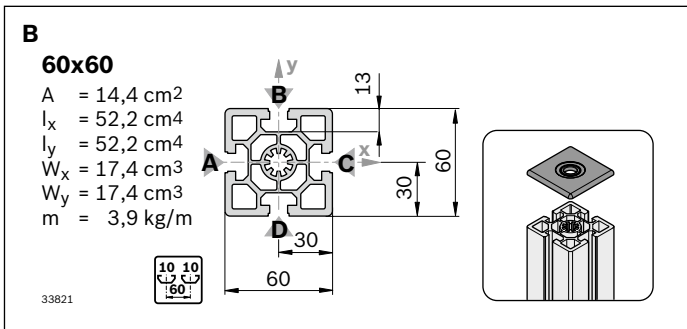

Strut profile 60x60	L (mm)	No.
1 pcs M12	60 ... 5600	<b>3 842 990 351/L</b>

Profile finishing: Thread cutting M12, see MGE catalog, chapter Strut profiles

Cover cap with hole	ESD	No.
60x60, black	20	<b>3 842 548 811</b>

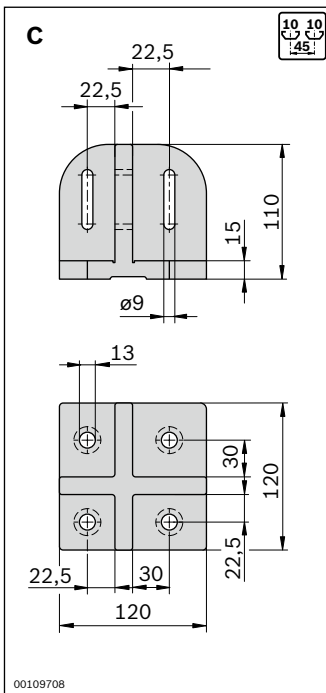

Base plate	ESD	No.
120x120	100	<b>3 842 527 553</b>

## ESD motor leg sets (STS drives on the AL system)

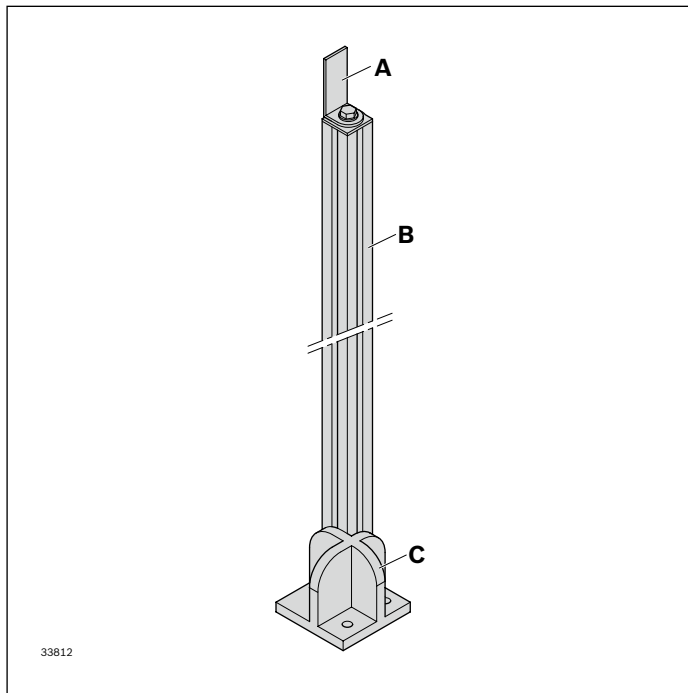

The connection between the STS motor leg set holder (**A**) and the core pull of the strut profile (**B**) is established via the M12 hexagon screw included in the scope of delivery of the holder.

Instead of the coated VarioFlow plus foot, the 120x120 base plate (**C**) included in the MGE program must be used. The connection of the base plate to the strut profile is done using T-bolts and flange nuts

### Required accessories:

- 4x T-bolts M8x30, 3 842 528 721, see page 63
- 4x flange nuts, 3 842 345 081, see page 63

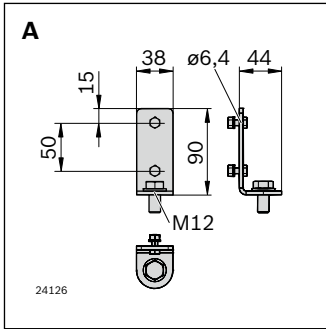

Holder engine support STS	No.
VFplus	Set 3 842 549 365

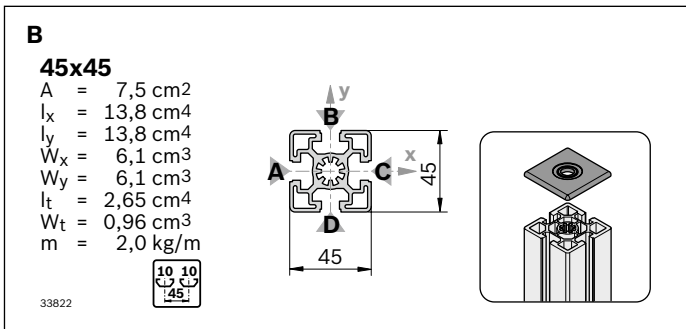

Strut profile 45x45	L (mm)	No.
1 pcs M12	60 ... 6000	3 842 990 517

Profile finishing: Thread cutting M12, see MGE catalog, chapter Strut profiles

Cover cap with hole	ESD	No.
45x45, black	20	3 842 548 797

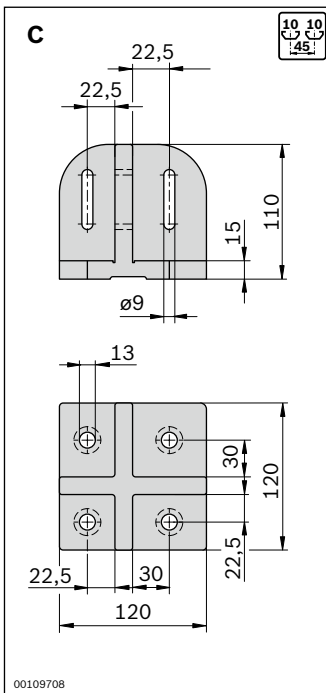

Base plate	ESD	No.
120x120	1	3 842 527 553

# Wedge conveyor

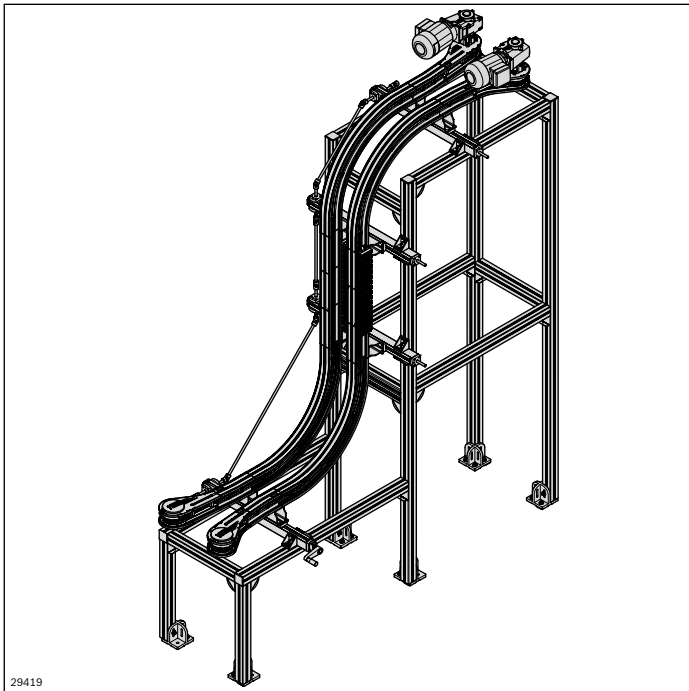

- A wedge conveyor is always used if the conveyed product
- cannot be transported vertically on a standard conveyor due to its design
  - cannot manage steep inclinations ( $> 30^\circ$ ) due to the position of its center of gravity
  - could be damaged by lateral or upper guides due to its sensitive surfaces
  - must not slide on  $90^\circ$  incline or decline section (as it would occur with a cleated chain system)
  - conveying is to be carried out without special sequencing

A wedge conveyor has two conveyors arranged in parallel to each other which can be quickly set at variable widths by means of the adjustment unit (AL).

	<b>Setting up a wedge conveyor</b>	<b>192</b>
	<b>Wedge conveyor adjustment unit</b>	<b>194</b>

## Setting up a wedge conveyor



- ▶ Size: 90
- ▶ The length of the wedge conveyor is limited to 7 m
- ▶ A curve wheel or sliding curves are available for chain recirculation, dependent on product size and version
- ▶ Only closed head drive (return unit) can be used
- ▶ The assembly module (see page 61/133) is mandatory
- ▶ The use of a 5° vertical curve is also recommended (see pages 133/140) for the infeed and outfeed, especially for small products
- ▶ Requires the use of the Advanced or Premium slide rails (see page 56/128 )



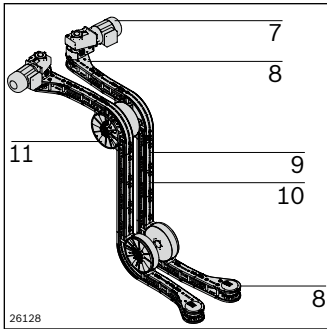

- 7** STS drive kit, see page 156
- 8** STS return unit/STS closed head drive, see page 152
- 9** STS section profile, see page 124
- 10** STS assembly module, see page 133
- 11** Curve wheel STS, see page 136 (STS sliding curves can also be implemented on request)

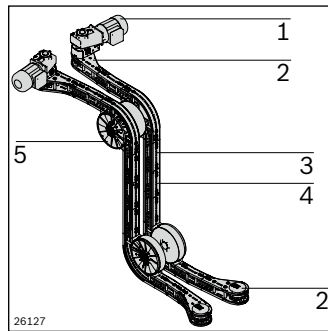
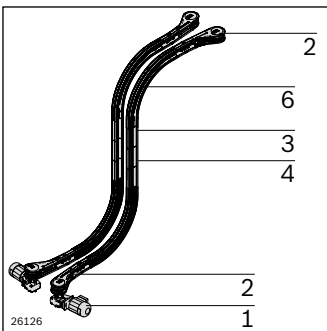

- 1** AL drive kit, see page 92
- 2** AL return unit/AL closed head drive, see page 86
- 3** AL section profile, see page 52/54
- 4** AL assembly module, see page 61
- 5** AL curve wheel, see page 68
- 6** Sliding curve horizontal AL, see page 72

**Frame made out of MGE components**

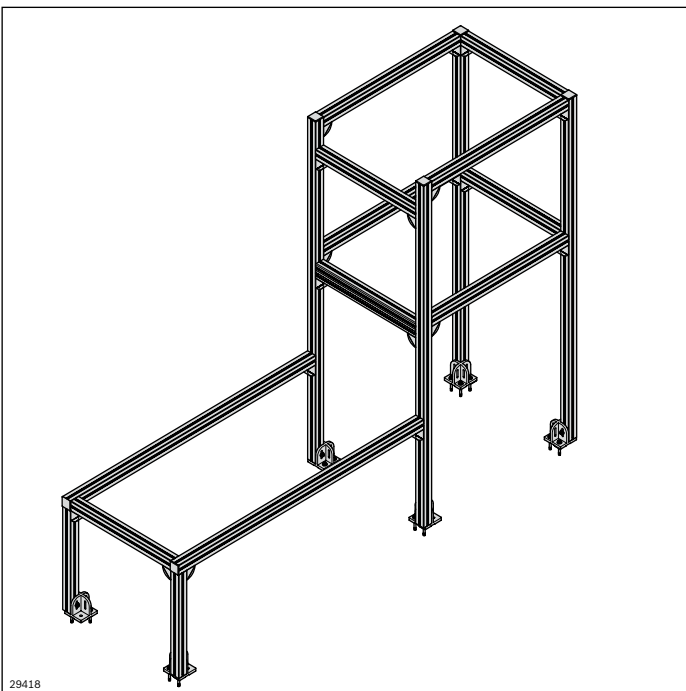

**Adjustment unit for width adjustment see page 194**

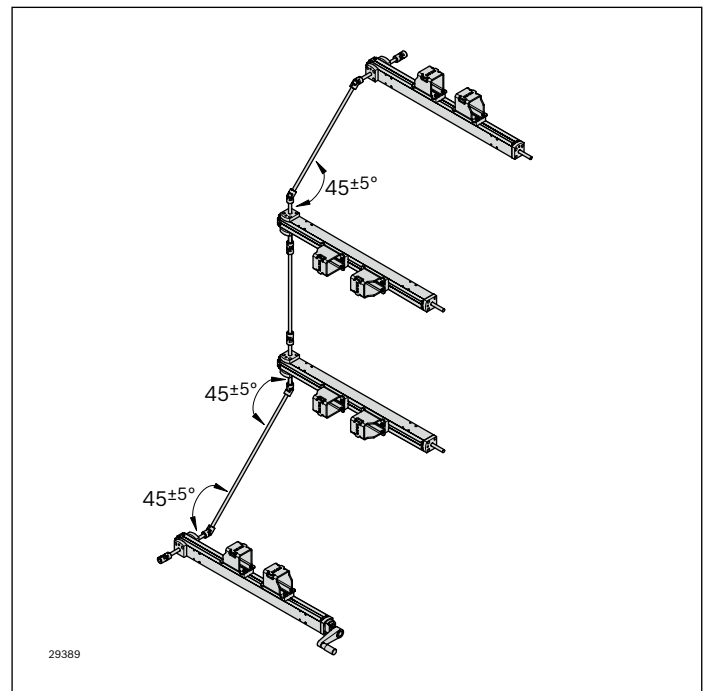

## Wedge conveyor adjustment unit

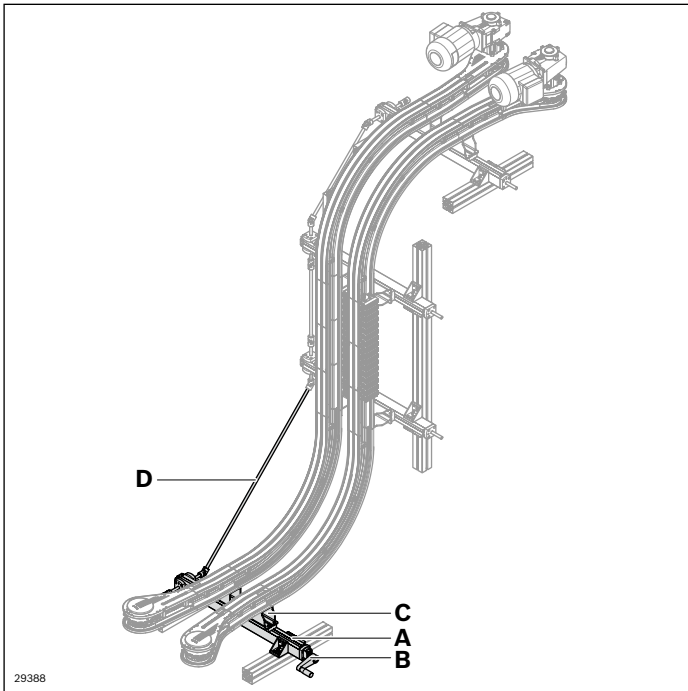

The adjustment unit is suitable for simply setting the wedge conveyor width during a format change for product widths ranging from 0 ... 410 mm.

The self-locking adjustment unit (**A**) can be simply mounted on the VarioFlow *plus* section profile using the connection kit (**C**) and connected to additional adjustment units via the profile rail (**D**).

The crank handle (**B**) with counter facilitates the setting of fixed track widths.

### Required accessories:

- B:** Crank handle incl. counter
- C:** Connection kit (Set)
- D:** Profile rail (see page 195)

### Scope of delivery:

- A:** Incl. 2 universal joints
- B:** Incl. counter mechanism
- C:** Incl. fastening material

### Material:

- A:** Aluminum, anodized; brass, steel
- C:** Steel, galvanized

### Condition on delivery:

- A:** Fully assembled
- B:** Partially assembled
- C:** Not assembled

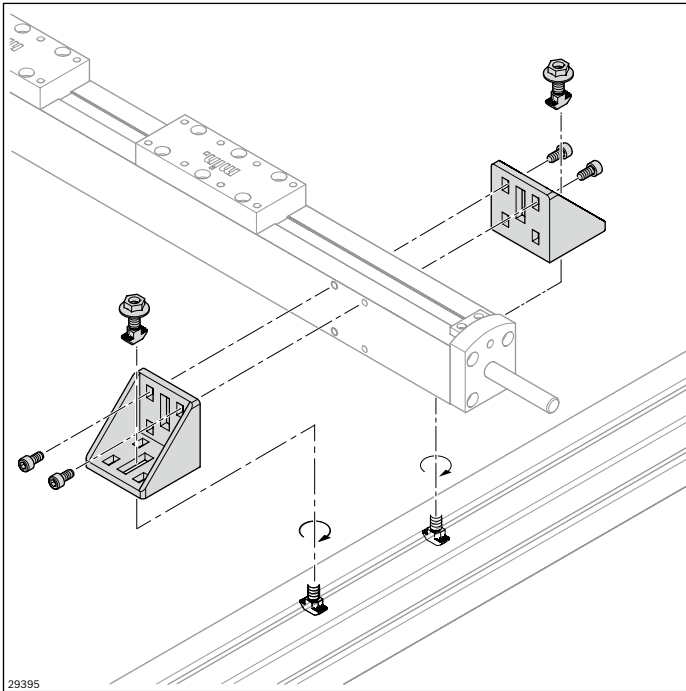

The adjustment unit can be fitted onto a frame made out of MGE profiles with four 60x60 brackets (3 842 523 546) and 8 ISO 4762-M6x16

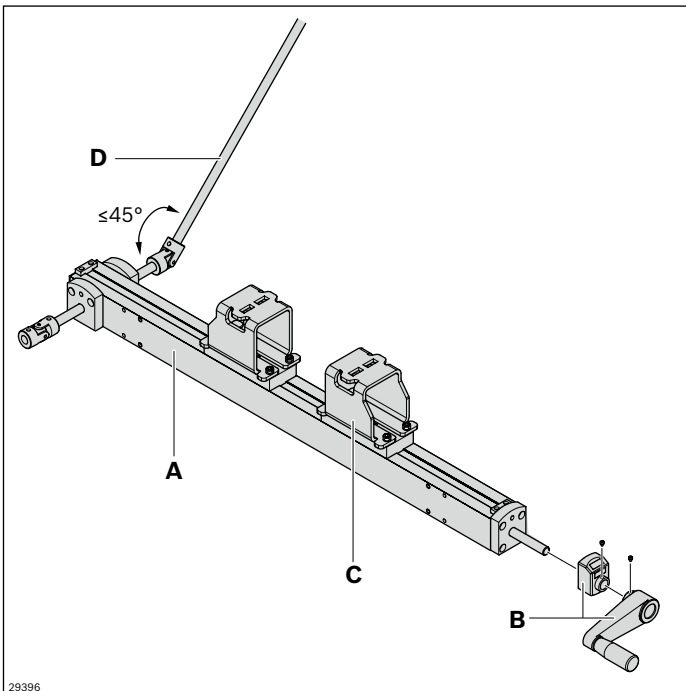

<b>Adjustment unit (A)</b>	<b>No.</b>
1 pcs	<b>3 842 547 971</b>
<b>Crank handle (B)</b>	<b>No.</b>
1 pcs	<b>3 842 547 990</b>
<b>Connection kit (C)</b>	<b>No.</b>
1 pcs	<b>3 842 547 729</b>
<b>Profile rail D12 (D)</b>	<b>No.</b>
1 pcs	<b>3 842 993 306/L</b>
6 pcs	<b>3 842 533 841</b>

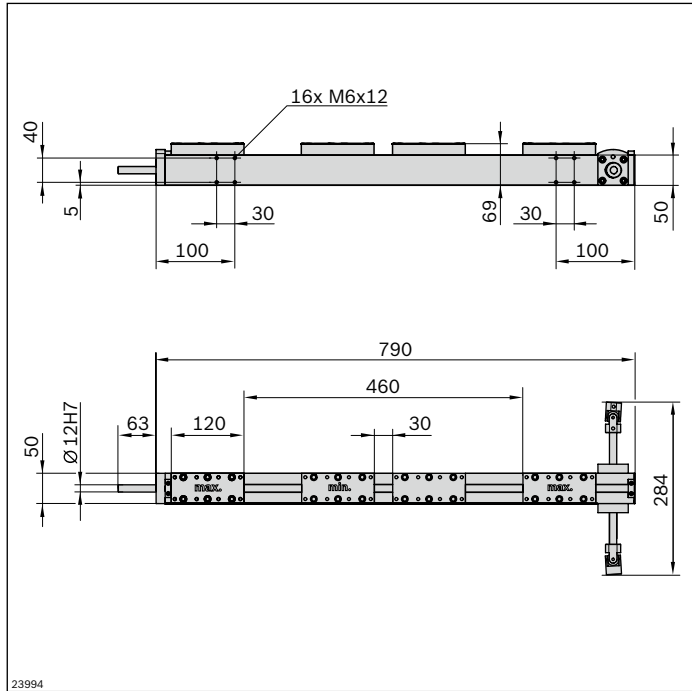

Adjustment unit

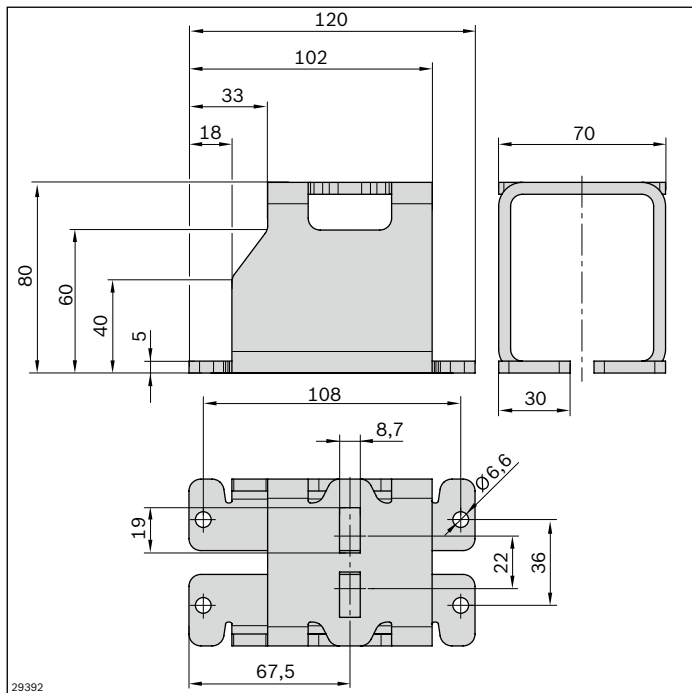

Connection kit

**Crank handle**

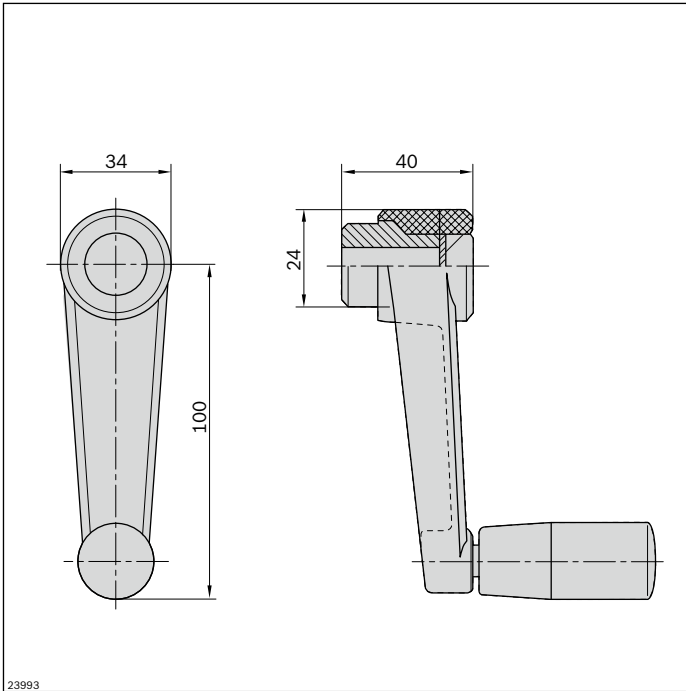

23993

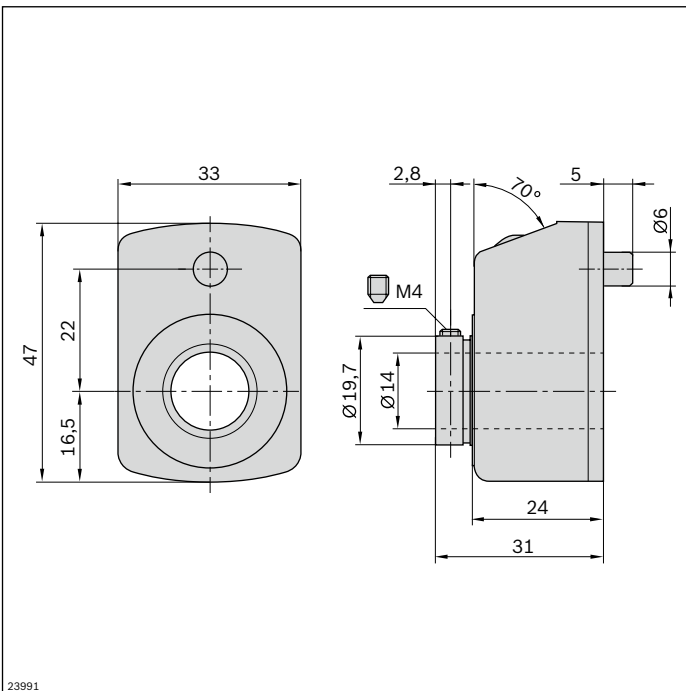





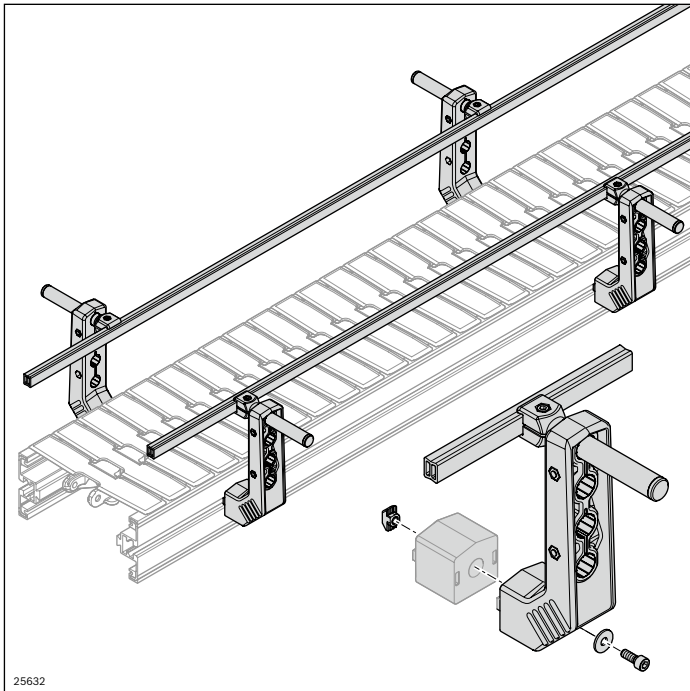



23991

# Lateral guide



- ▶ Universal use in aluminum and stainless steel system
- ▶ Minimal planning effort thanks to clear building system
- ▶ Easy to clean thanks to ample draining surfaces

Optimum adaptation to the conveyed material  
due to a variety of combination options

	<b>Components for lateral guides</b>	<b>200</b>
	<b>Profile rails for lateral guides</b>	<b>202</b>
	<b>Holder for lateral guide, fix</b>	<b>205</b>
	<b>Lateral guide holder, flexible</b>	<b>207</b>
	<b>Clamping lever</b>	<b>213</b>
	<b>Pneumatically adjustable lateral guide</b>	<b>214</b>
	<b>Barrier</b>	<b>216</b>
	<b>Universal diverter</b>	<b>218</b>

## Components for lateral guides

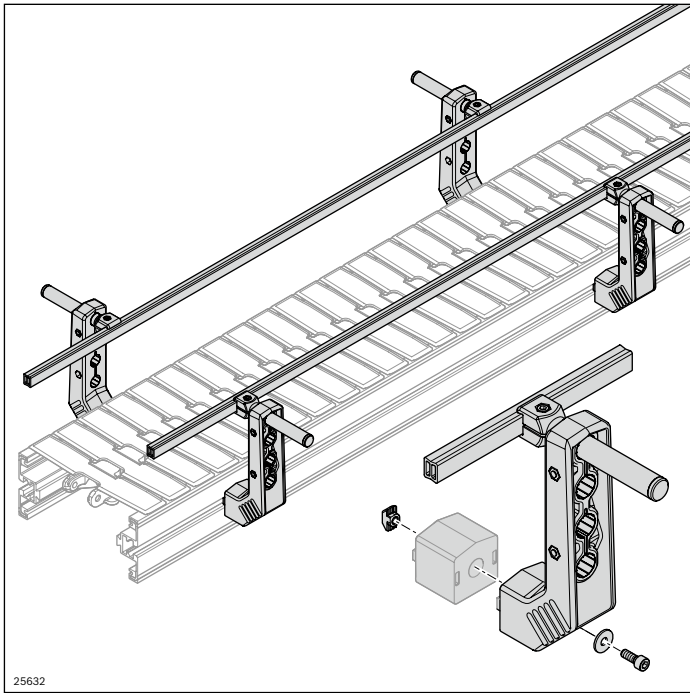

- Wide variety of profile rail and holder combinations for individual solutions
- Easy to clean
- Sturdy
- Only one tool required for adjustment
- 10 mm slot interface



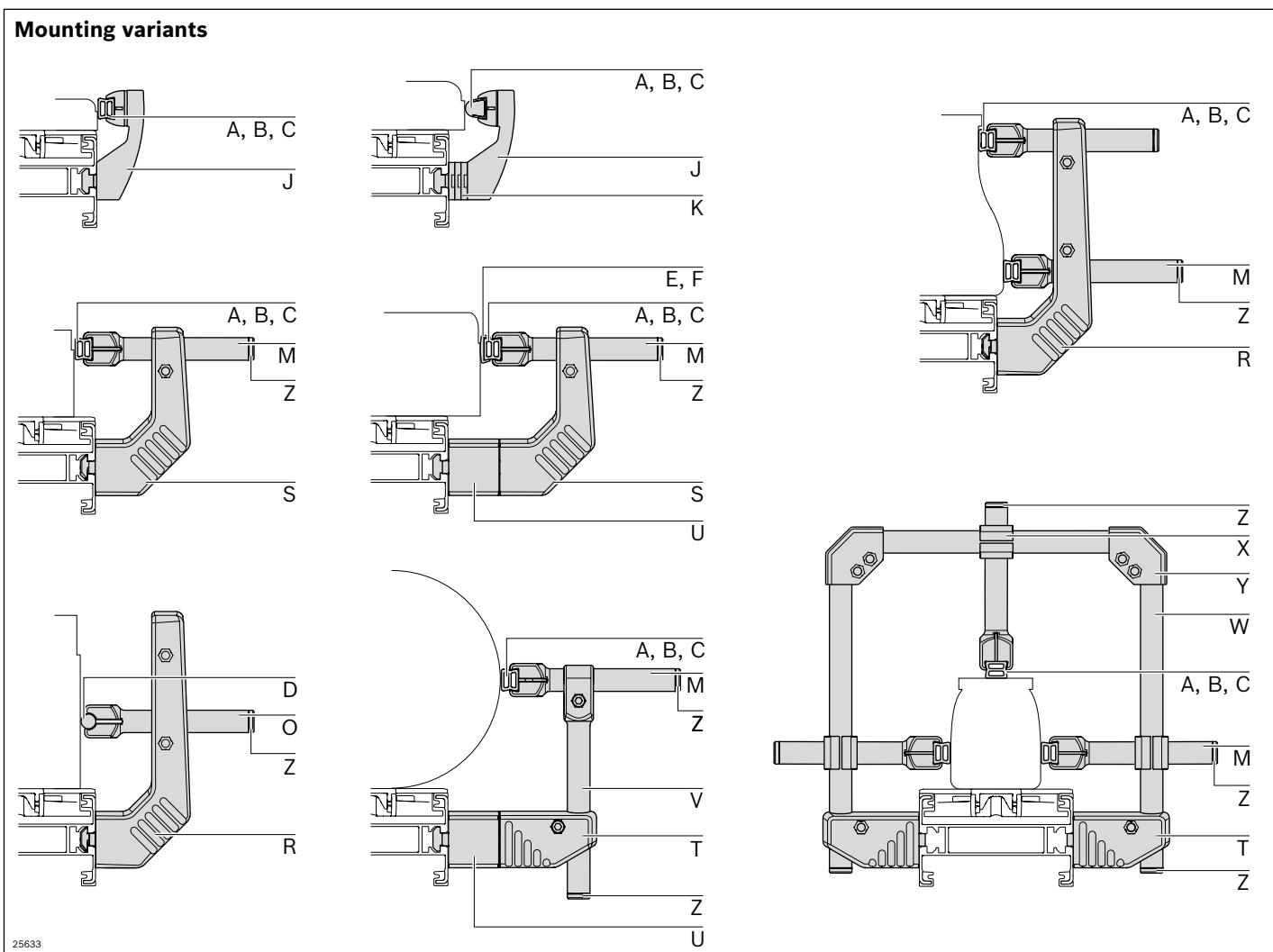

- A:** Aluminum profile rail, see page 202  
**B:** HDPE profile rail, see page 203  
**C:** Profile rail 17x17.5, see page 203  
**D:** Profile rail D12, see page 203  
**E:** Slide rail, narrow, see page 203  
**F:** Slide rail, high, see page 204  
**J:** Holder, fixed, see page 206  
**K:** Spacer plate, see page 206  
**M:** Clamping holder C L100, see page 209  
**O:** Clamping holder D12 L100, see page 209

- R:** Holder L204, see page 210  
**S:** Holder L134, see page 210  
**T:** Holder L45, see page 211  
**U:** Spacer, see page 211  
**V:** Vertical clamping holder D18 L160, see page 211  
**W:** Tube D18, see page 212  
**X:** Cross piece, see page 212  
**Y:** Corner piece, see page 212  
**Z:** Plug, see page 212

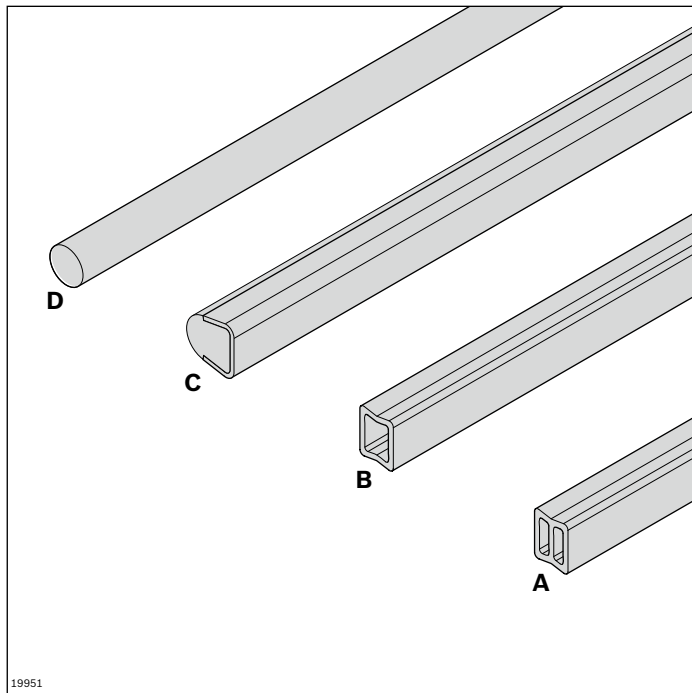

## Profile rails for lateral guides

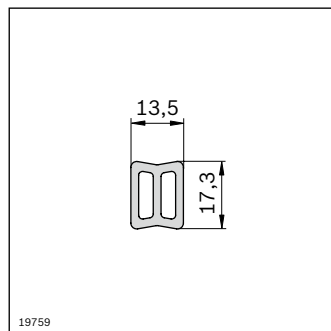
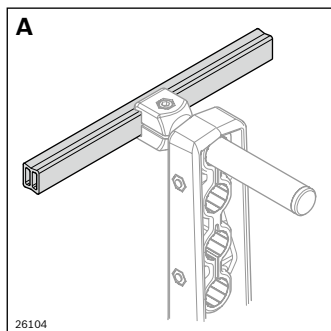

- Profile rails for lateral guiding of transported material
- Compatible with holders for lateral guide, fix (see page 205), and holders for lateral guide, flexible (see page 207)
- Various materials and geometries for different applications



- Aluminum profile rail for robust lateral guides
- Holder distance: max. 750 mm, less with accumulation pressure

Aluminum profile rail		L (mm)	No.
<b>A</b>	1 pcs 	200 ... 3000	<b>3 842 993 887/L</b>
<b>A</b>	 20 pcs	3000	<b>3 842 538 829</b>

Material: Aluminum; natural, anodized  
 Accessories: Slide rail narrow (**E**); slide rail high (**F**); outer profile connector (**G**); inner profile connector (**H**); cap (**I**); clamping holder C L100 (**M**); clamping holder C (**N**); holder (**J**); clamping head (**L**); clamping head (**Q**)

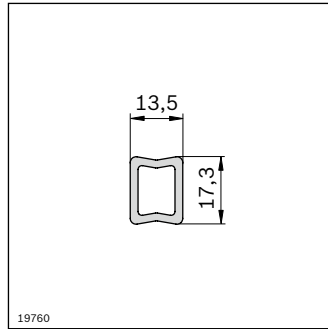
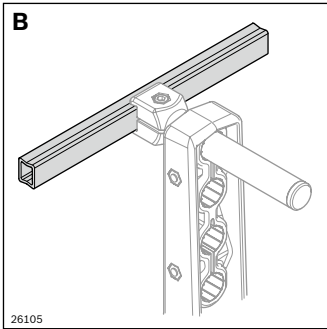

- HDPE profile rail for light applications
- Bendable
- Spacer distance: approx. 300 mm

HDPE profile rail		L (mm)	No.
<b>B</b>	1 pcs	3000	<b>3 842 538 388</b>

Material: HDPE; gray  
 Accessories: Slide rail narrow (E); slide rail high (F); outer profile connector (G); inner profile connector (H); cap (I); clamping holder C L100 (M); clamping holder C (N); holder (J); clamping head (L); clamping head (Q)

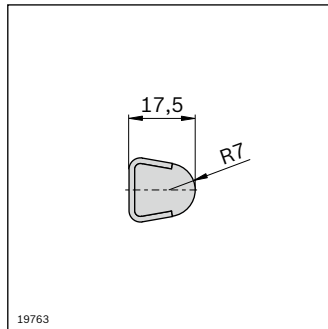
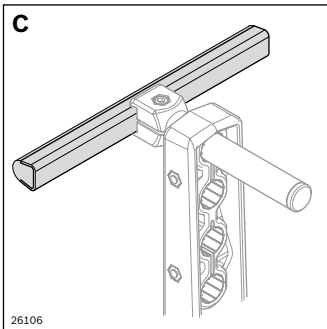

- Profile rail 17x17.5 in robust stainless steel version with PE guide for gentle product handling
- Holder distance: max. 750 mm, less with accumulation pressure

Profile rail 17x17.5		L (mm)	No.
<b>C</b>	1 pcs	200 ... 3000	<b>3 842 994 863/L</b>
<b>C</b>	20 pcs	3000	<b>3 842 529 850</b>

Material: Steel; stainless/PE; natural  
 Accessories: Outer profile connector (G); clamping holder C L100 (M); clamping holder C (N); holder (J); clamping head (L); clamping head (Q)

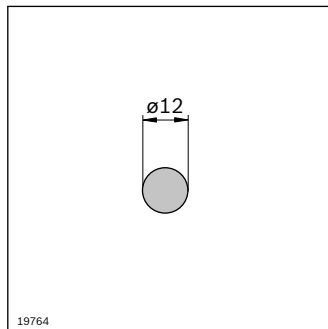
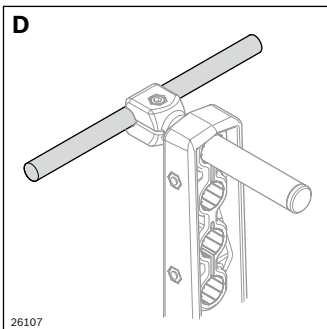

- Profile rail D12 in robust stainless steel version
- Holder distance: max. 750 mm, less with accumulation pressure

D12 profile rail		L (mm)	No.
<b>D</b>	1 pcs	200 ... 3000	<b>3 842 993 306/L</b>
<b>D</b>	6 pcs	3000	<b>3 842 533 841</b>

Material: Steel; stainless  
 Accessories: Clamping holder D12 L100 (O); clamping holder D12 (P)

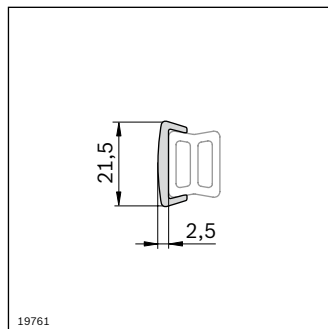
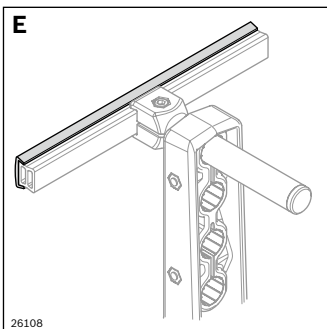

- Clip-on slide rail for aluminum or HDPE profile rail
- For gentle product transport and minimum wear to HDPE profile rail

Slide rail, narrow		L (mm)	ESD	No.
<b>E</b>		3000		<b>3 842 538 209</b>
<b>E</b>		3000	⚡	<b>3 842 539 340</b>

Material: HDPE; gray  
 ESD: PE-UHMW, conductive, black

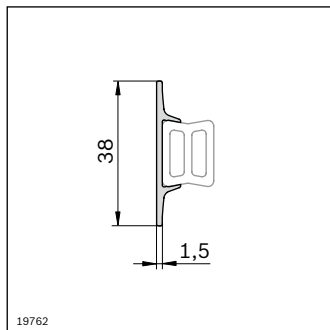
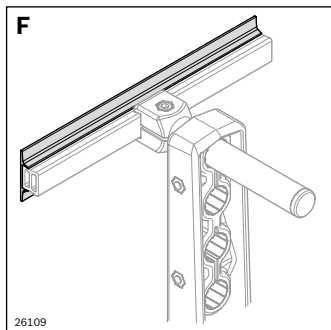

- Clip-on slide rail for aluminum or HDPE profile rail
- Wide guiding surface
- For gentle product transport and minimum wear to HDPE profile rail

Slide rail, high	L (mm)	No.
<b>F</b>	3000	<b>3 842 538 389</b>

Material: HDPE; gray

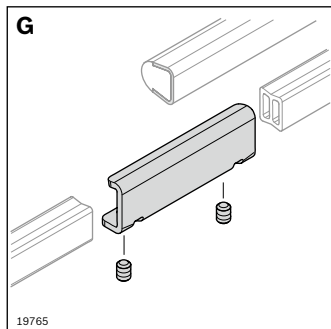

- Outer profile connector for aluminum profile rails (A), HDPE profile rail (B), 17x17.5 profile rail (C)

Outer profile connector	No.
<b>G</b>	10 <b>3 842 539 613</b>

Material: Steel; stainless  
Scope of delivery: incl. 2 x headless setscrews

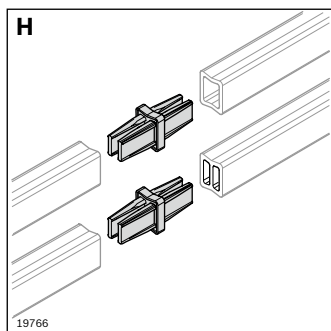

- Inner profile connector for profile rail in aluminum (A), HDPE (B)

Inner profile connector	No.
<b>H</b>	10 <b>3 842 539 345</b>

Material: PA; black, conductive

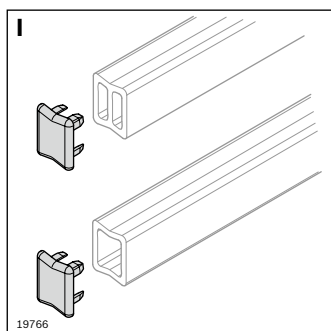

- Cap for aluminum (A) profile rail, HDPE (B) profile rail

Cover cap	No.
<b>I</b>	10 <b>3 842 538 208</b>

Material: PA; black, conductive

# Holder for lateral guide, fix

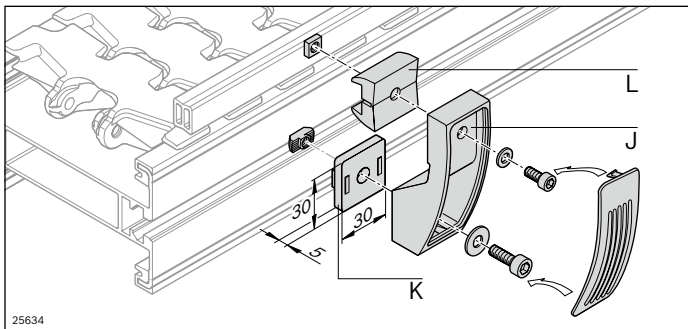

- Holders for lateral guides with fixed installation height and fixed guide width

7

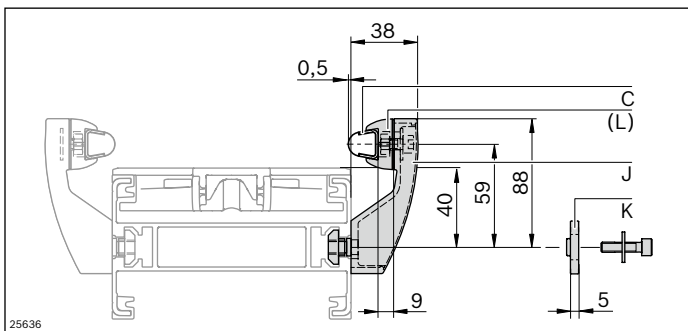
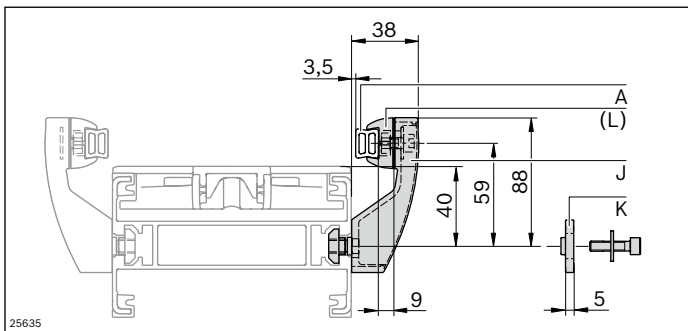

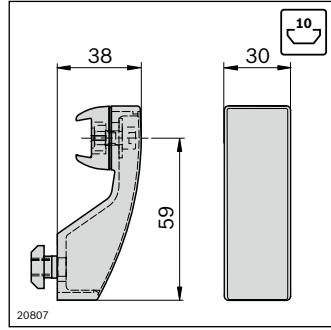
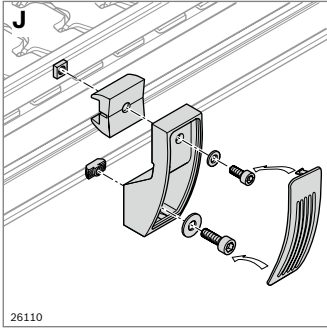

- Holder, fixed, for profile rail in aluminum (A), HDPE (B) and 17x17.5 (C)
- For fixed guide width
- Guide width increased through use of spacer plate (K)

Holder, fixed	No.
J Set	3 842 527 851
Material:	PA; black Fastening material: steel; galvanized
Scope of delivery:	Incl. clamping head, fastening material

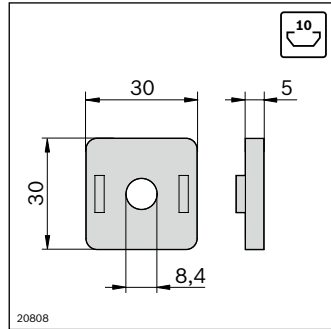
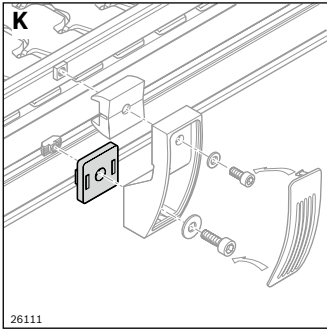

- Spacer plate for holders, fixed, to enlarge the guide width

Spacer plate	No.
K	10 3 842 527 738
Material:	PA; black

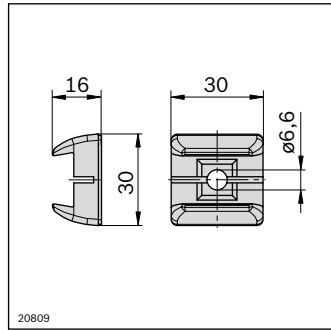
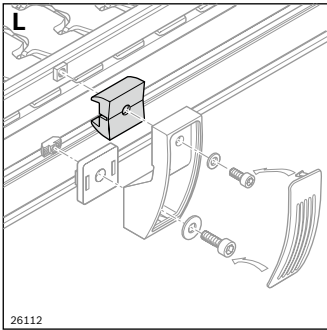

- Clamping head for on-site construction of supports for protruding transported material

Clamping head	No.
L Set	10 3 842 536 295
Material:	PA; black Fastening material: steel; galvanized
Scope of delivery:	Incl. fastening material

## Lateral guide holder, flexible

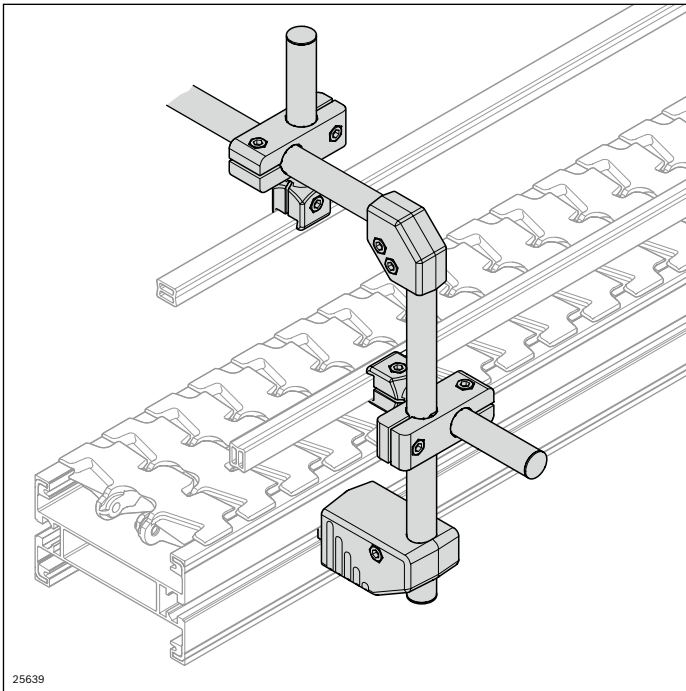

- Holders and clamping holders make variable adjustment of the guide height and width possible
- Easy to clean

**Note:** For lateral guide stability, at least two holders must be connected with a continuous profile rail.

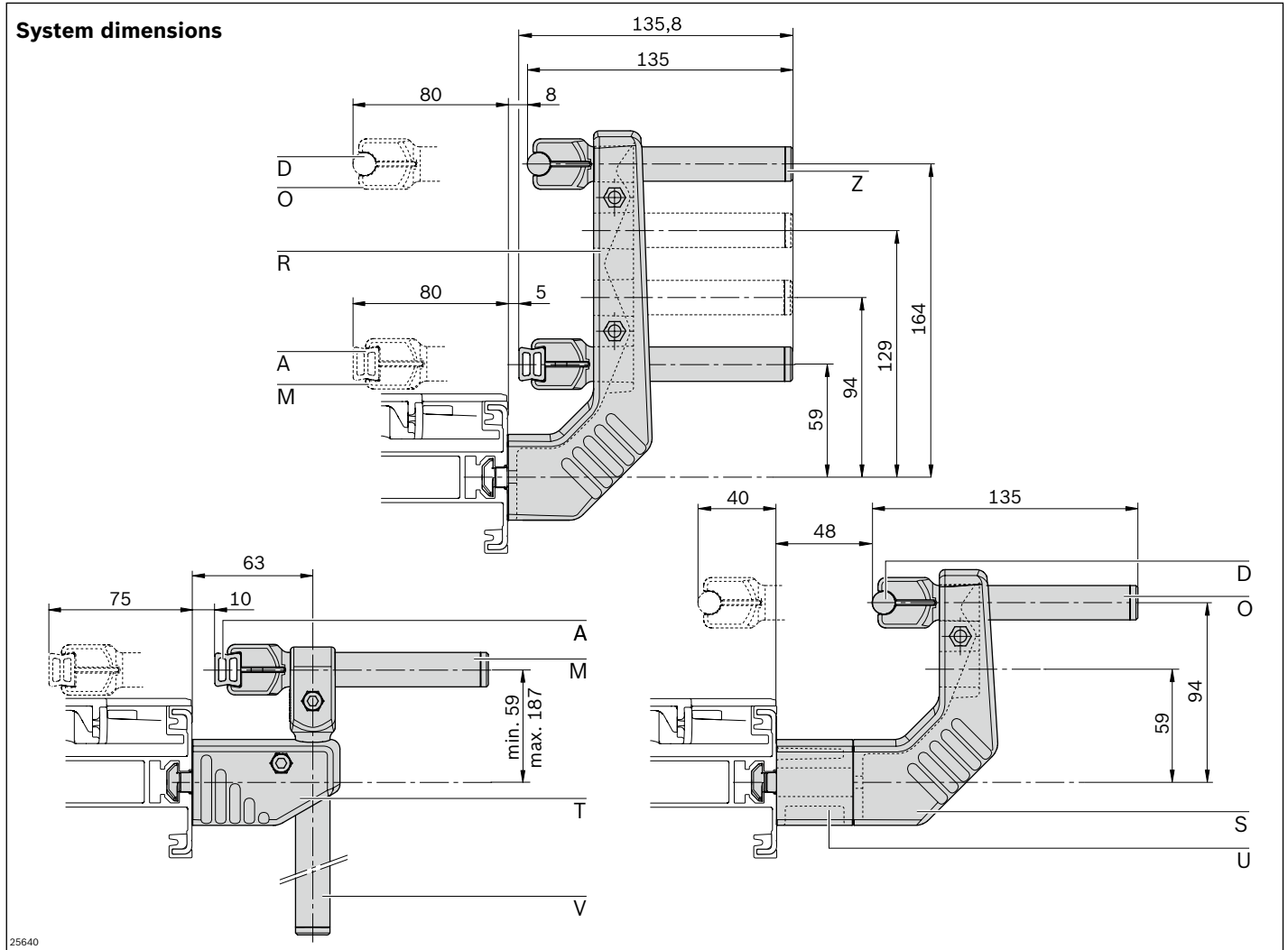

- A:** Aluminum profile rail, see page 202
- D:** Profile rail D12, see page 203
- M:** Clamping holder C L100, see page 209
- O:** Clamping holder D12 L100, see page 209
- R:** Holder L204, see page 210
- S:** Holder L134, see page 210
- T:** Holder L45, see page 211
- U:** Spacer, see page 211
- V:** Vertical clamping holder D18 L160, see page 211
- Z:** Plug, see page 212



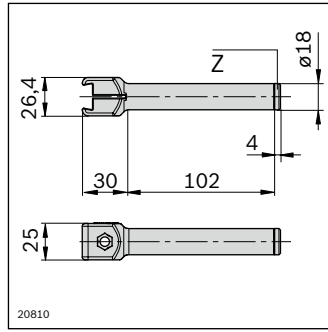
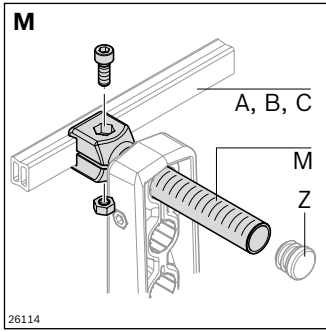

- Clamping holder C L100 for supporting aluminum (A), HDPE (B) or 17x17.5 (C) profile rail versions
- Scaling in mm and inch for simple alignment

Clamping holder C L100		No.
<b>M</b>	10	<b>3 842 539 499</b>
Material:	Clamping holder: PA; black Nut, bolt: Steel; stainless	
Accessories:	Plug (Z)	

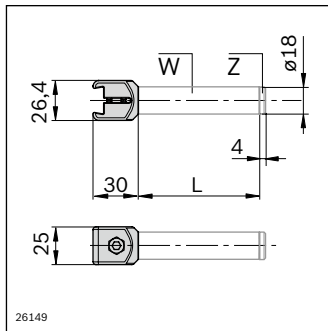
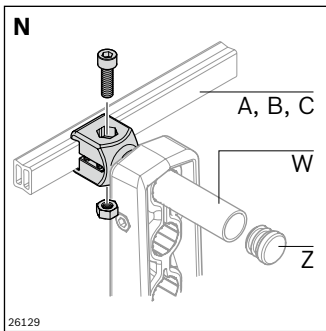

- Clamping holder C for mounting profile rails aluminum (A), HDPE (B) or 17x17.5 (C) profile rail versions
- In conjunction with tube 18 (W) for constructing longer clamping holders

Clamping holder C		No.
<b>N</b>	10	<b>3 842 547 228</b>
Material:	Clamping holder: PA; black Nut, bolt: Steel; stainless	
Accessories:	Plug (Z) Tube D18 (W)	

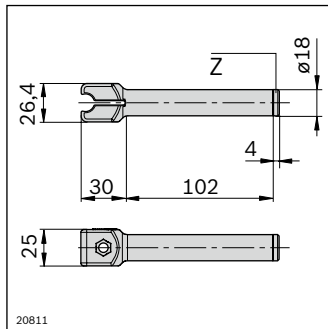
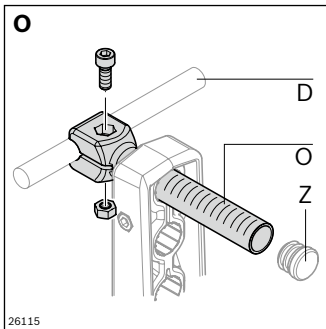

- Clamping holder D12 L100 for supporting profile rails D12 (D)
- Scaling in mm and inch for simple alignment

Clamping holder D12 L100		No.
<b>O</b>	10	<b>3 842 539 498</b>
Material:	Clamping holder: PA; black Nut, bolt: Steel; stainless	
Accessories:	Plug (Z)	

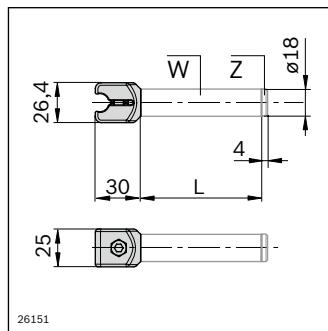
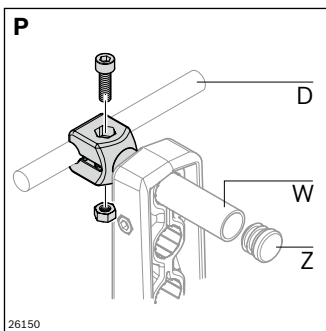

- Clamping holder D12 for supporting profile rails D12 (D)
- In conjunction with tube 18 (W) for constructing longer clamping holders

Clamping holder D12		No.
<b>P</b>	10	<b>3 842 547 227</b>
Material:	Clamping holder: PA; black Nut, bolt: Steel; stainless	
Accessories:	Plug (Z) Tube D18 (W)	

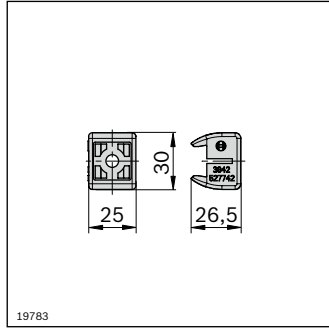
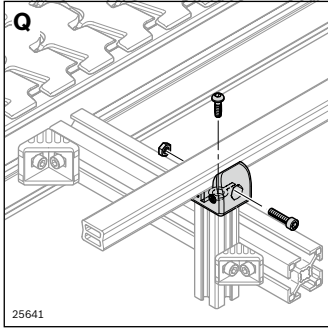

- Clamping head for supporting aluminum (A), HDPE (B) or stainless steel profile rail versions with PE guide (C)
- Direct mounting on profiles with 10 mm slot

Clamping head		No.
Q Set	10	3 842 528 009
Material:	Clamping holder: PA; black Fastening material: steel; galvanized	
Scope of delivery:	Incl. fastening material	

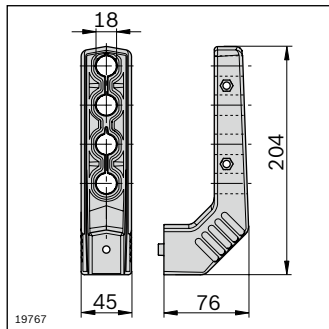
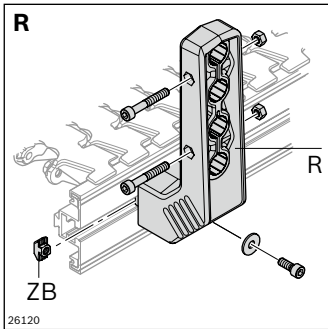

- Holder for fastening clamping holders C, C L100, D12, or D12 L100
- Various installation heights possible for clamping holders
- Variable guide widths possible
- Spacer (U) for added enlargement of guide width

Holder L204		No.
R Set	100	3 842 539 494
ZB T-nut for AL	100	3 842 530 285
ZC T-nut for STS	20	3 842 546 706

Material: PA, black  
Fastening material: Steel; stainless

Scope of delivery: Incl. fastening material (except for T-nuts)

Required accessories: T-nut for AL or STS

Optional accessories: Spacer (U)

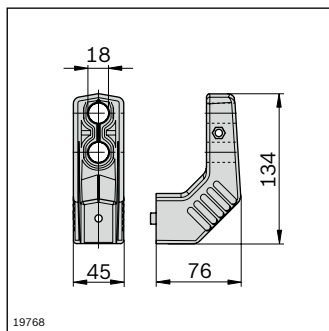
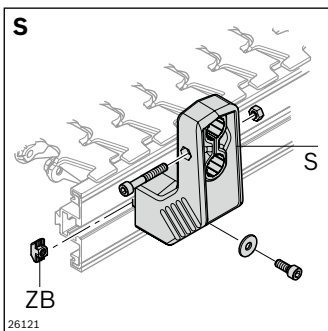
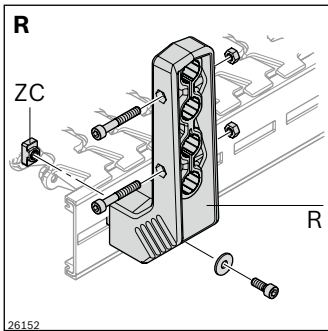

- Holder for fastening clamping holders C, C L100, D12, or D12 L100
- Various installation heights possible for clamping holders
- Variable guide widths possible
- Spacer (U) for added enlargement of guide width

Holder L134		No.
S Set	100	3 842 539 495
ZB T-nut for AL	100	3 842 530 285
ZC T-nut for STS	20	3 842 546 706

Material: PA; black  
Fastening material: Steel; stainless

Scope of delivery: Incl. fastening material (except for T-nuts)

Required accessories: T-nut for AL or STS

Optional accessories: Spacer (U)

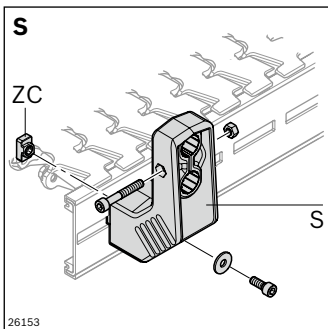

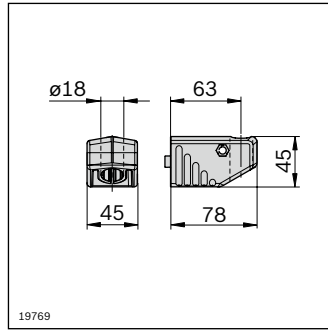
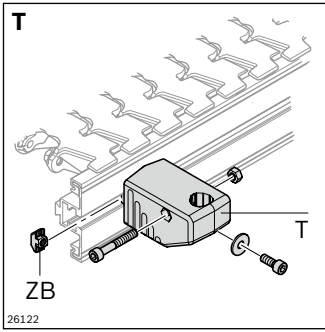

- Holder L45 for fastening vertical clamping holders or tube D18
- For infinitely height-adjustable lateral guides
- Spacer (**U**) for enlargement of guide width

Holder L45		No.
<b>T</b> Set	10	<b>3 842 539 496</b>
<b>ZB</b> T-nut for AL	100	<b>3 842 530 285</b>
<b>ZC</b> T-nut for STS	20	<b>3 842 546 706</b>

Material: PA; black  
 Fastening material: Steel; stainless  
 Scope of delivery: Incl. fastening material (except for T-nuts)  
 Required accessories: T-nut for AL or STS  
 Optional accessories: Spacer (**U**)

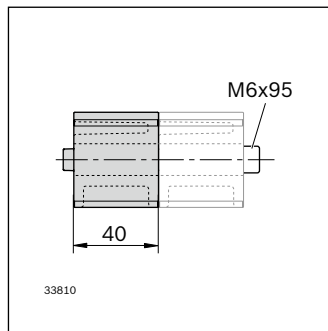
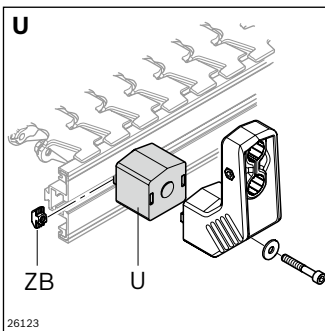
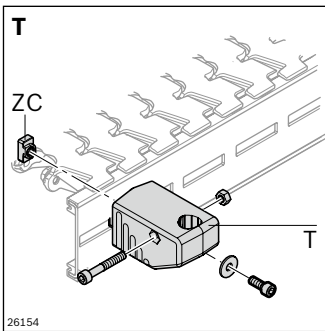

- Spacer for guide width enlargement

Spacer		No.
<b>U</b> Set	10	<b>3 842 539 497</b>
<b>ZB</b> T-nut for AL	100	<b>3 842 530 285</b>
<b>ZC</b> T-nut for STS	20	<b>3 842 546 706</b>

Material: PA; black  
 Fastening material: Steel; stainless  
 Scope of delivery: Incl. fastening material (except for T-nuts)  
 Required accessories: T-nut for AL or STS

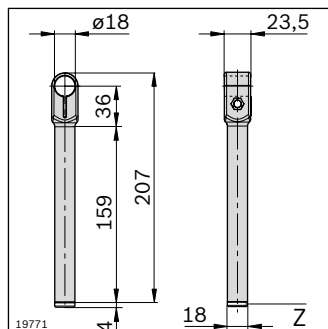
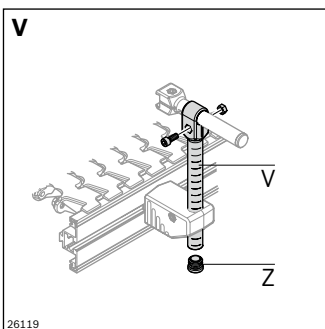
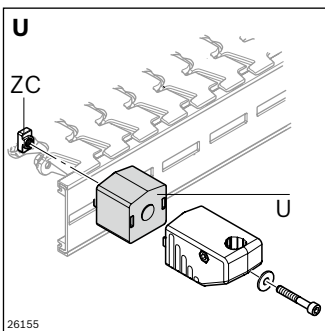

- Vertical clamping holder for constructing height-adjustable guides

Vertical clamping holder D18 L160		No.
<b>V</b>	10	<b>3 842 539 500</b>

Material: PA; black  
 Nut, screw: Steel; stainless  
 Accessories: Plug (**Z**)

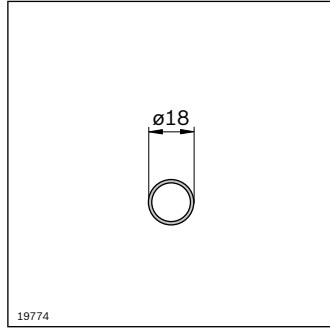
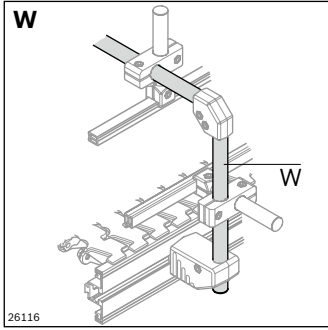

- Tube D18 for constructing height-adjustable vertical holders or cross members for upper guides

Tube D18	L (mm)	No.
<b>W</b>	3000	<b>3 842 539 339</b>
Material:	Stainless steel	
Accessories:	Plug ( <b>Z</b> )	

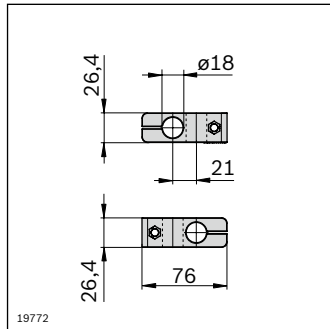
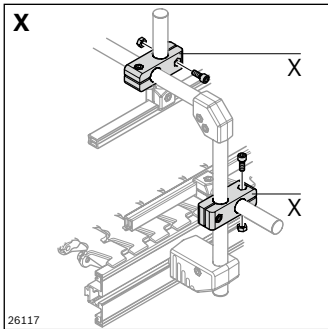

- Cross piece for intersecting, perpendicular connections of tubes D18 (**W**) and clamping holders C L100 (**M**) or D12 L100 (**O**)

Cross piece	No.
<b>X</b>	10 <b>3 842 539 501</b>
Material:	Cross piece: PA; black
	Nut, screw: Steel; stainless

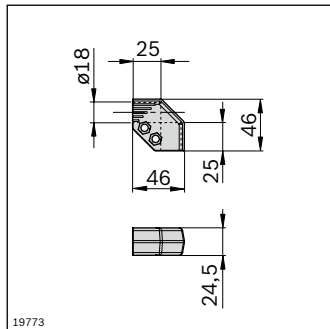
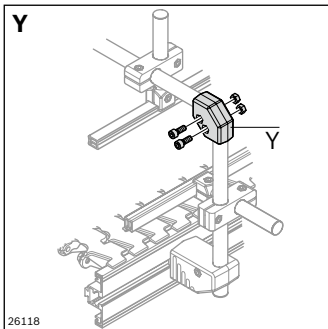

- Corner piece for end-to-end, perpendicular connections of tubes D18 (**W**) and clamping holders C L100 (**M**) or D12 L100 (**O**)

Corner piece	No.
<b>Y</b>	10 <b>3 842 539 505</b>
Material:	Corner piece: PA; black
	Nut, screw: Steel; stainless

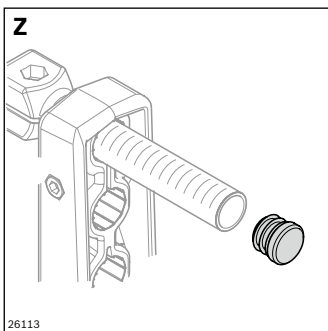

- Plug for clamping holder C L100 (**M**), clamping holder D12 L100 (**O**), vertical clamping holder D18 L160 (**V**) or tube D18 (**W**)

Plug	No.
<b>Z</b>	10 <b>3 842 539 826</b>
Material:	PA; black

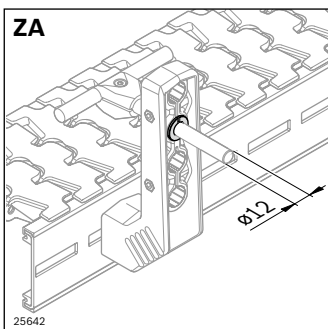

- Reducing adapter for accommodating round profiles ø12 in D18 mountings, e.g. for customer-specific clamping holders

Reducing adapter	No.
<b>ZA</b>	20 <b>3 842 539 344</b>
Material:	PA; black

# Clamping lever

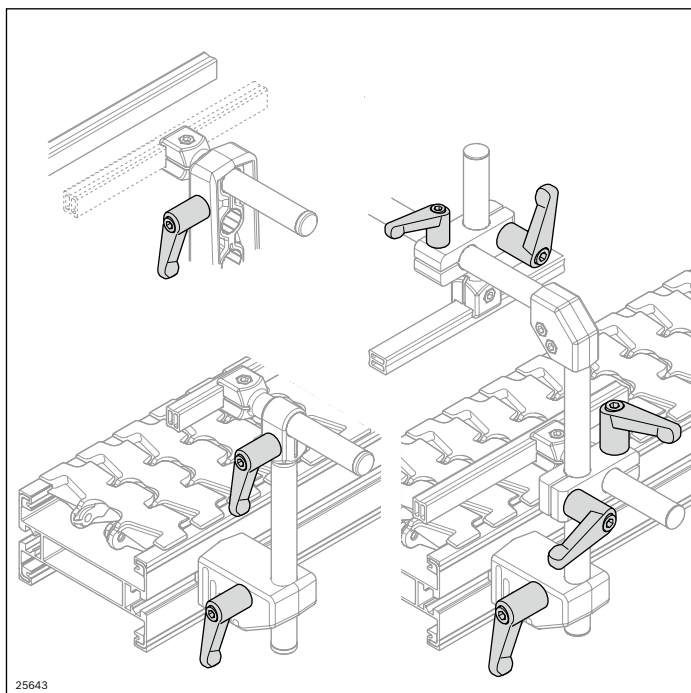

25643

- For easy adjustment of lateral guide holders
- Clamping lever M6x25 for cross piece
- Clamping lever M6x40 for the holder

7

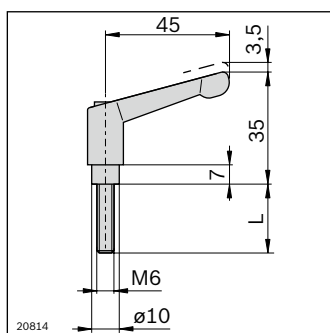

20814

Clamping lever	L (mm)	No.
<b>M6x25</b>	25	<b>3 842 528 540</b>
<b>M6x40</b>	40	<b>3 842 528 539</b>

Material: Lever: diecast zinc; black plastic coated  
Screws: steel; galvanized and black chrome-plated

## Pneumatically adjustable lateral guide

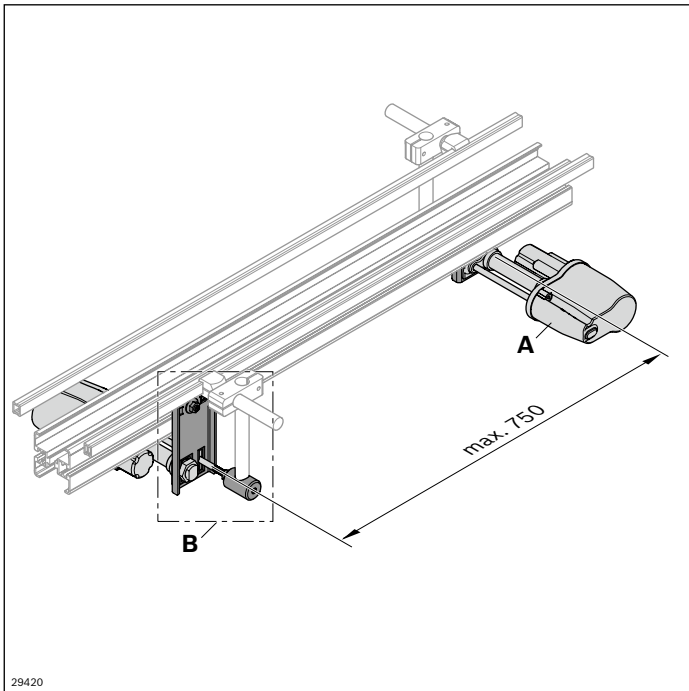

The complete lateral guide can be adapted to rapidly changing product dimensions, especially when the conveyors are not easily accessible. The pneumatically adjustable lateral guide is composed of the adjustment unit (**A**), the assembly kit (**B**) and components from the lateral guide program.

- Size: 65-320
- Max. pressure against the lateral guide (on one side): 30 N/700 mm
- Synchronous, balanced adjustment
- Adjustment by means of pneumatic valve (operating pressure 4 ... 5 bar, switching every 2 sec. (depending on length of the pneumatic pipes and the number of adjustment units per valve))
- Adjustment range for each side: 16 stroke à 2 mm = 32 mm, after 16 switching operations the adjustment unit returns to its initial position
- Maximum number of adjustment units per valve: 8 pcs
- Position monitoring by customer is recommended

► Mounting and adjustment mechanisms are placed under the conveyor system for easy accessibility of the transported material

► Mounting and adjustment also in horizontal and vertical curves. A customer-side adjustment is required for horizontal curves

Required accessories:

- Tube 18 mm (**W**), cross piece (**X**), clamping holder (**M,O**), profile rail (**A, B, C, D**) (see Lateral Guide chapter on page 198)
- One 4/2 directional control valve per 8 adjustment units

Scope of delivery:

**B:** Incl. fastening material

Condition on delivery:

**A:** Fully assembled

**B:** Not assembled

Material:

**A:** AL anodized, PE, steel, galvanized steel, PA

**B:** Galvanized steel, AL anodized

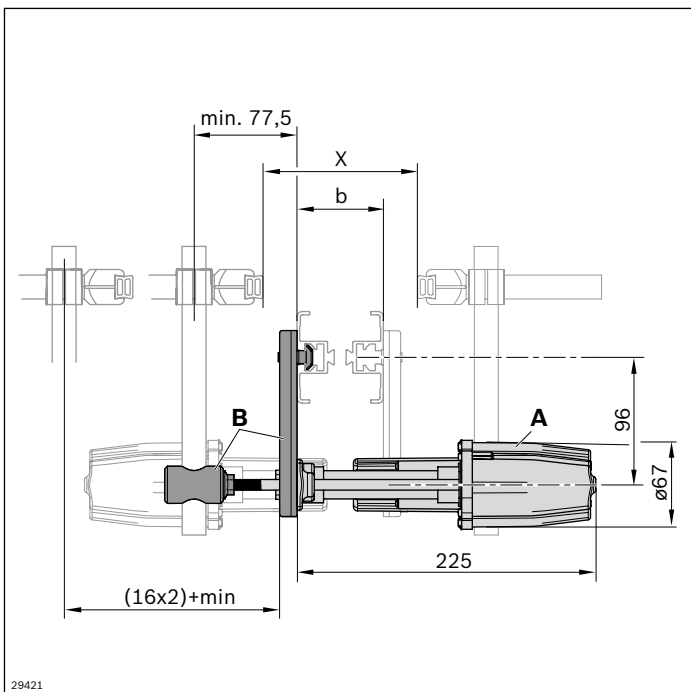

29421

Adjustment unit	No.
A	3 842 547 707

Mounting kit	No.
B	3 842 547 718

Track width b	X min	X max
65	0	116
90	0	141
120	0	171
160	0	211
240	0	291
320	0	371

## Barrier

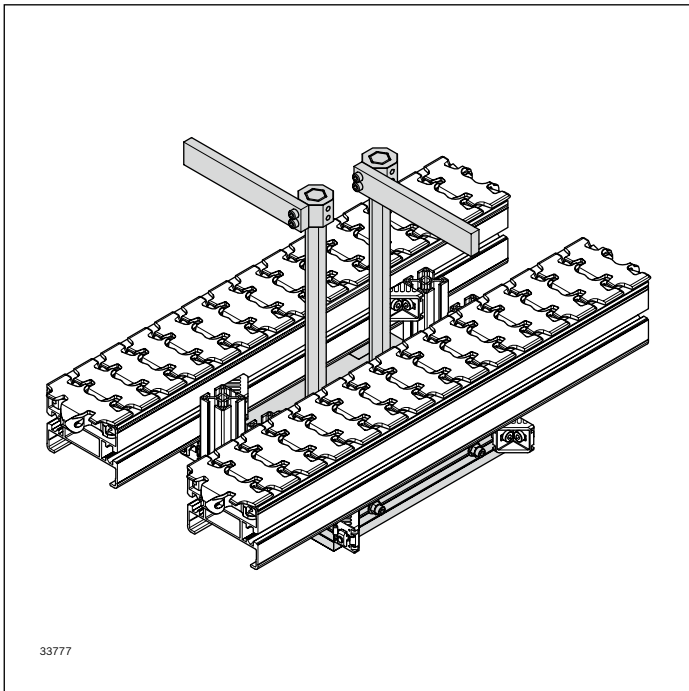

For the control-free merging of two sections into one The product that arrives first has right of way (Traffic Police).

- Size: all track widths
- Only suitable for dry operation
- The height of the barrier arm should be set as close as possible to the surface of the chain (any protrusion can be shortened if necessary)
- Minimum clearance between parallel tracks: 40 mm
- Minimum-maximum load: see diagram on page 217
- For higher loads, the accumulation pressure must be reduced, e.g. via pre-singulation

- ▶ Barrier length adjustable to product width
- ▶ Reducing back pressure through pre-isolation

Scope of delivery:  
incl. fastening material (includes all necessary basic components for the installation)

Material:  
aluminum, steel

Condition on delivery:  
Partially assembled



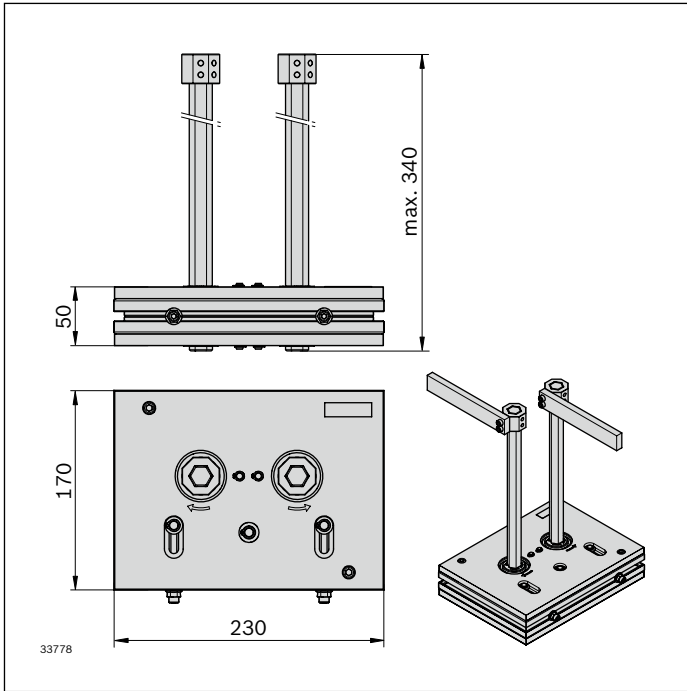

Barrier	No.
	3 842 553 070

7

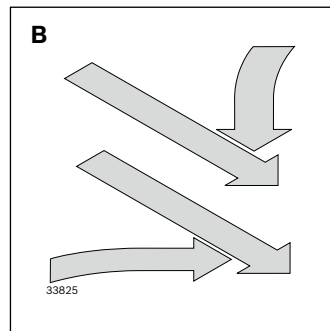
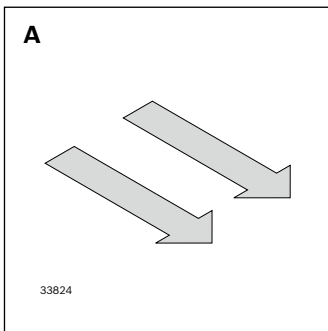

**A:** Standard solution, scope of delivery  
**B:** Adaptation of the barrier by the customer possible via MGE components

**Minimum / maximum load**

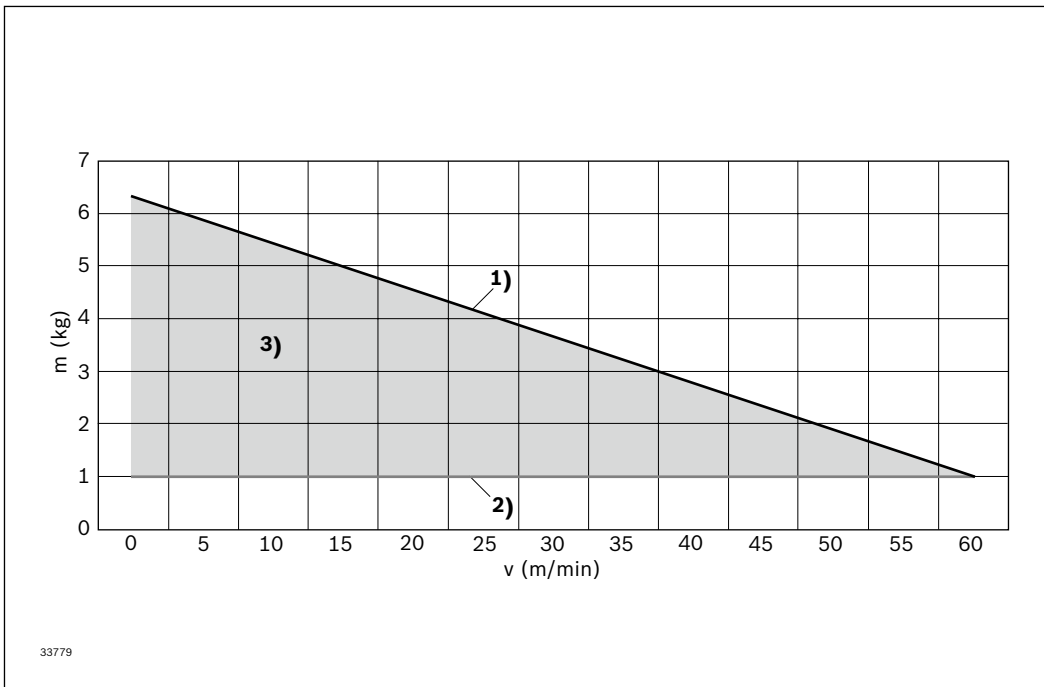

m (kg) mass  
 v (min/max) speed  
 1) Maximum load  
 2) Minimum load  
 3) Permissible range

## Universal diverter

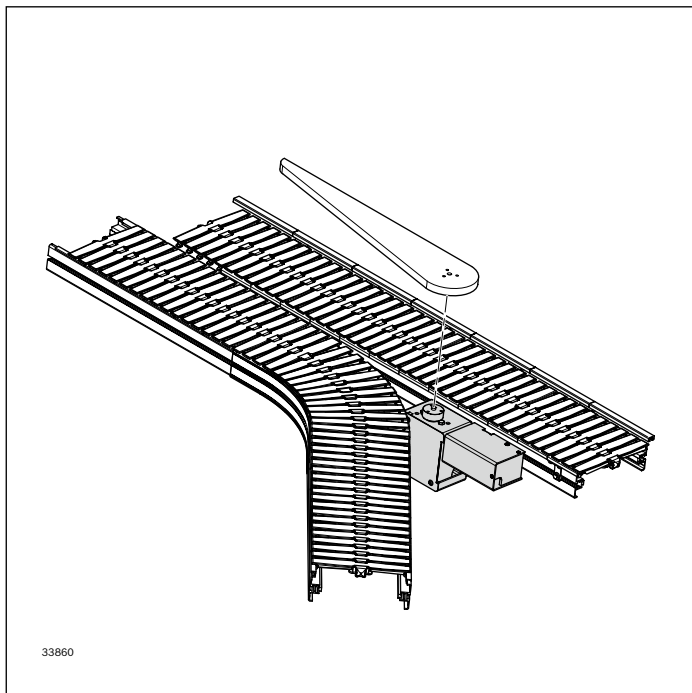

For changing tracks between main and branch section

- Size: all track widths (max. product width = chain width)
- Pneumatically operated
- Max. product weight: 20 kg

**Note:**

- The diverter arm and the end stop must be prepared by the user depending on the track width and product size
- For stability reasons, the closed section profile must be used for track widths 65-120, or, if open section profiles are used, two cross connectors must be used in the fixing area of the universal diverter

**Required accessories:**

- Diverter arm
- End stop (open/branch: against lateral guide or on user-side)
- For the cylinder:
  - 2x G1/8" throttle non-return valves
  - 2x sensors
  - 2x sensor supports
  - 1x 3/2 directional control valve
- Cylinder description ISO 6432 with:
  - Piston  $\varnothing 25$
  - Piston rod thread M10x1.25
  - Connections G1/8"
  - Piston rods  $\varnothing 10$
  - Cylinder outer thread M22x1.5

**Scope of delivery:**

Partially assembled kit

**Material:**

steel, aluminum, PC

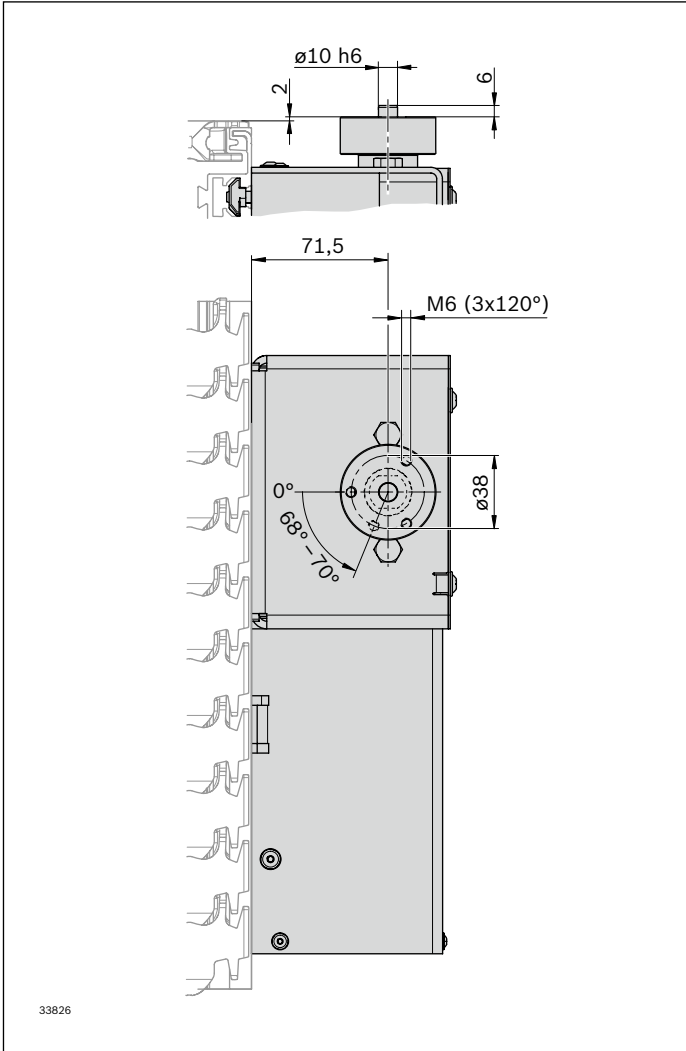





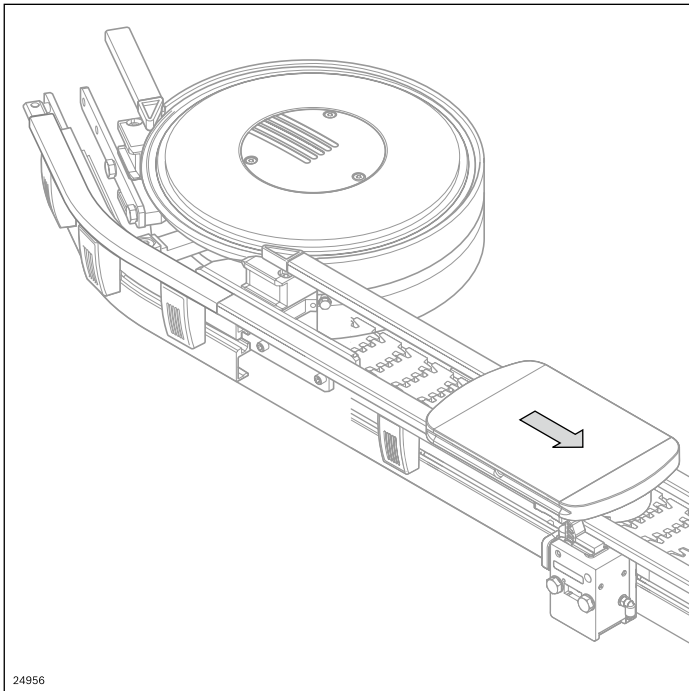







Universal diverter	No.
	3 842 547 703

# Workpiece pallet system (WT)



- ▶ Numerous components for WT control, such as a diverter, stopper, positioning unit, etc.
- ▶ Wear pads with different materials can be selected
- ▶ Compatible with the ID 15 identification system

Secure transport of parts thanks to the modular design  
with comprehensive additional components

	<b>VarioFlow workpiece pallet (WT)</b>	<b>222</b>
	<b>WT plate End piece</b>	<b>224</b>
	<b>Lateral guide for workpiece pallets</b>	<b>226</b>
	<b>Curve wheel lateral guide</b>	<b>230</b>
	<b>Stop gate VE 2/VF</b>	<b>232</b>
	<b>Return stop WT</b>	<b>234</b>
	<b>Position sensor accessories</b>	<b>236</b>
	<b>Switch bracket</b>	<b>238</b>
	<b>Positioning unit</b>	<b>240</b>
	<b>Section transfer</b>	<b>244</b>
	<b>Diverter</b>	<b>246</b>
	<b>Junction</b>	<b>254</b>
	<b>Rocker WT system</b>	<b>258</b>

# VarioFlow workpiece pallet (WT)

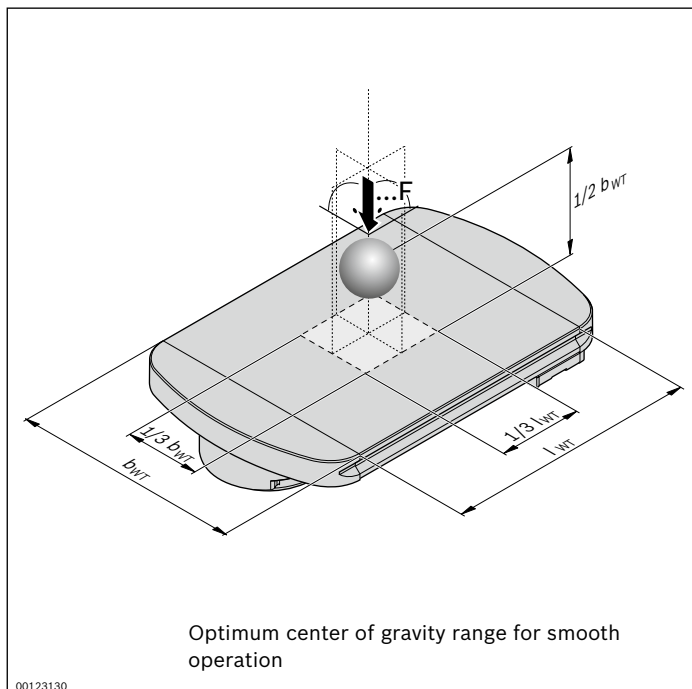
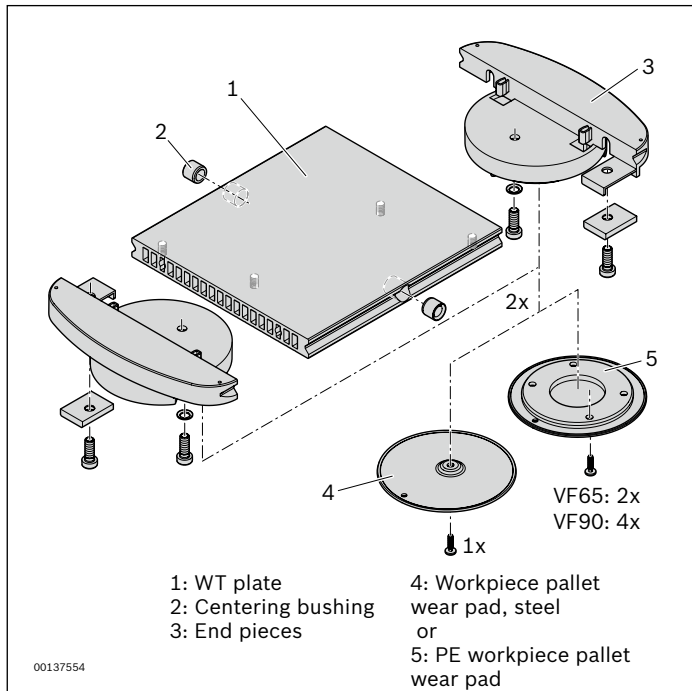

For transporting products that are not suitable for accumulation operation or are unstable due to their geometry

- Max. transport speed for operation with workpiece pallets:  $v_N = 18 \text{ m/min}$
- Workpiece pallet wear pads either made of:
  - Steel, for use in harsh environments
  - PE, for use in clean environments
- Workpiece pallet load (workpiece, support, etc.)
  - Size 65: 8 kg
  - Size 90: 8 kg
- The modular concept allows for WT lengths of up to 500 mm\*. With centering bushings for positioning in the positioning unit.
  - For WT with  $L > 300 \text{ mm}$ , combine 2 curve wheels  $90^\circ$  with intermediate section (min. 200 mm).
  - For WT with  $L < 300 \text{ mm}$ ,  $180^\circ$  curve wheel possible.
- Minimum length of the workpiece pallet:
  - Size 65:  $L_{\min} = 76 \text{ mm}$
  - Size 90:  $L_{\min} = 114 \text{ mm}$
- Minimum length of the workpiece pallet in order to be positioned by the positioning unit (see page 240):
  - Size 65:  $L_{\min} = 125 \text{ mm}$
  - Size 90:  $L_{\min} = 125 \text{ mm}$

Minimum length WT for passive bridge  $L \geq 300$

- ▶ Level workpiece pallet surfaces with no indentations
- ▶ The entire top of the WT can be built upon since everything else on the section is installed lower than the top of the WT.
- ▶ Compatible with the ID 15 and ID 200 identification systems
  - Integrated installation of a mobile data tag is possible
- ▶ The product can also protrude beyond the WT if the position of the center of gravity is taken into consideration.

Material:

- WT plate: Aluminum; natural, anodized
- End pieces: PA; black
- Workpiece pallet wear pads: Steel; stainless,  $HV \geq 480$  or PE

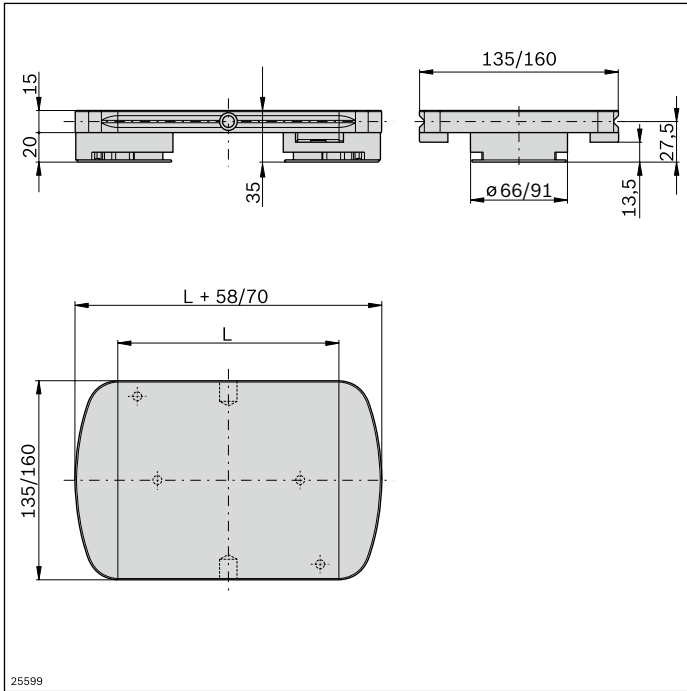

25599

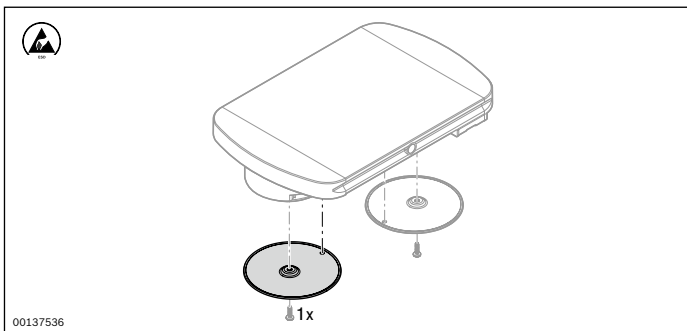

00137536

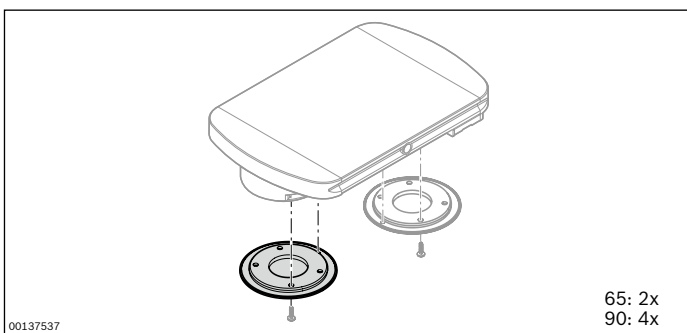

00137537

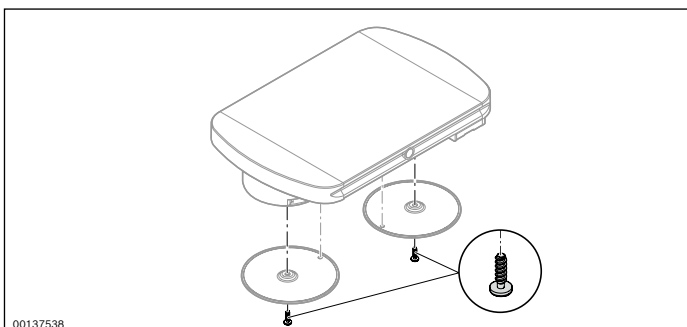

00137538

Workpiece pallet <sup>1)</sup>	L (mm)	No.
VFplus 65	150	1 <b>3 842 541 888</b>
VFplus 90	175	1 <b>3 842 541 889</b>

<sup>1)</sup> Mounted without wear pad, with positioning bushing

The mounted workpiece pallet must be provided with wear pads (steel or PE) by the customer.

Steel wear pad	No.
VFplus 65	10 <b>3 842 528 773</b>
VFplus 90	10 <b>3 842 528 772</b>

Required accessories:

Screw **3 842 543 246** (not in scope of delivery)

**Note:** We recommend using the gray chain, see page 19.

PE wear pad	No.
VFplus 65	10 <b>3 842 541 566</b>
VFplus 90	10 <b>3 842 541 567</b>

Required accessories:

Screw **3 842 543 246** (not in scope of delivery)

Screw	No.
	100 <b>3 842 543 246</b>

# WT plate End piece

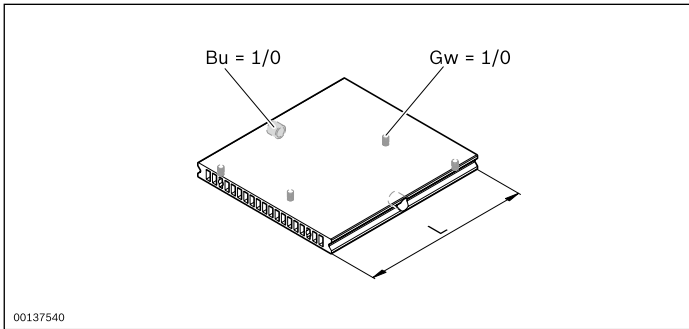

WT plate	Bu	Gw	L (mm)	No.
VFplus 65	0; 1	0; 1	30 ... 6000	<b>3 842 996 204/...</b>
VFplus 90	0; 1	0; 1	30 ... 6000	<b>3 842 996 205/...</b>

Parameters	Size	L <sub>min</sub> (mm)	L <sub>max</sub> (mm)
Bu = 1	65/90	125	500
Gw = 1	65	76	500
	90	114	500

**Bu = 1:** with holes for centering bushings for positioning in the positioning unit (centering bushings not in scope of delivery)

**Bu = 0:** without holes for centering bushings

**Gw = 1:** with holes to assemble the end pieces

**Gw = 0:** without holes to assemble the end pieces

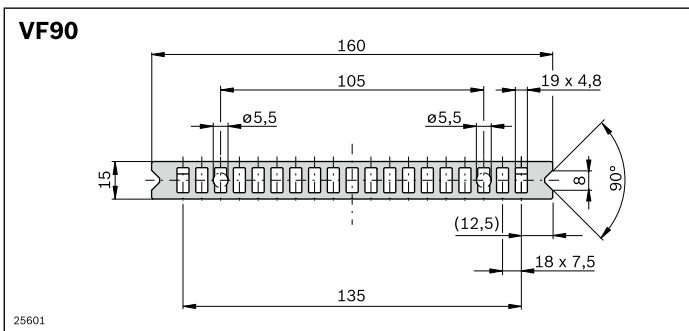
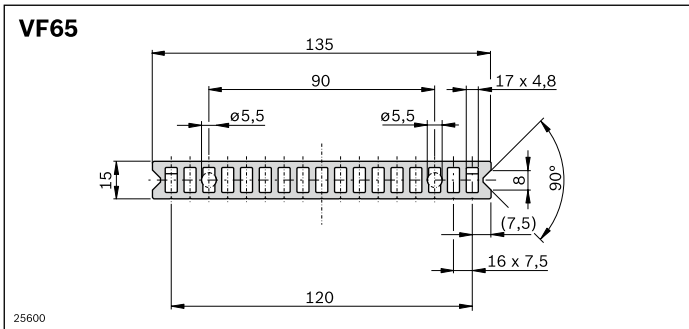



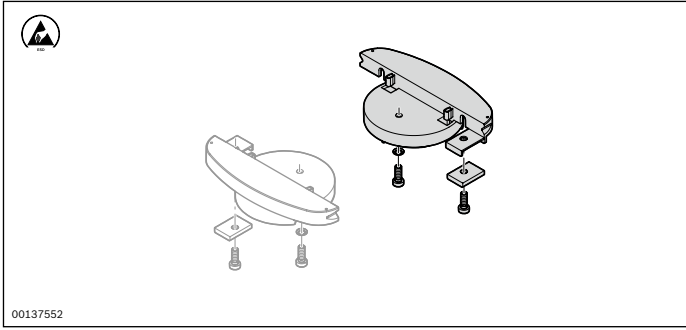

End piece	No.
VFplus 65	10 3 842 541 902
VFplus 90	10 3 842 541 903

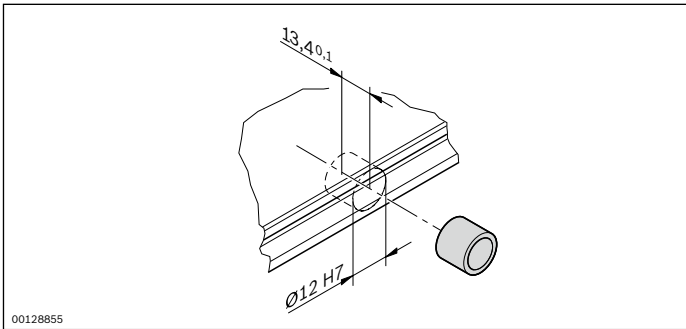

Centering bushing	No.
	1 3 842 535 081

## Lateral guide for workpiece pallets

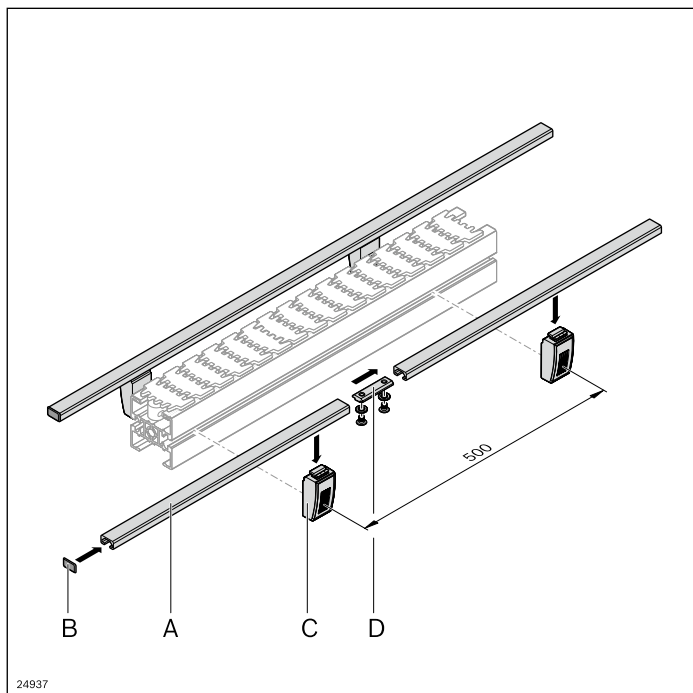

- ▶ Strut profile (**A**) to laterally guide the workpiece pallet. Pre-bent lateral guides for curves available on request
- ▶ Lateral guide holder (**C**). Distance between holders in conveying direction: 500 mm
- ▶ Profile connector (**D**) for end-to-end joining of any profiles

Optional accessories:

**A:** Bending tool for lateral guide: see page 266

Scope of delivery:

**C:** Incl. fastening parts (as shown)

Material:

- **A:** Aluminum; natural, anodized
- **B, C:** PA, black
- **D:** Fastening parts: Galvanized steel

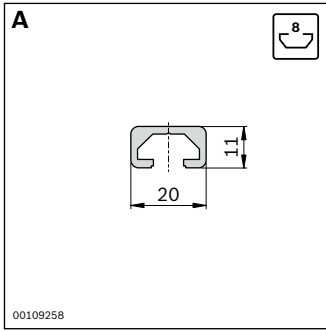

Strut profile 11x20	L (mm)	No.
A	30 ... 2000	1 <b>3 842 992 476/...</b>
A	2000	10 <b>3 842 513 581</b>

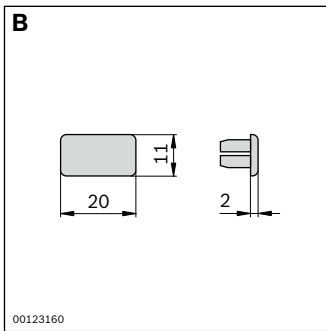

Cover cap 11x20	No.
B	20 <b>3 842 513 584</b>

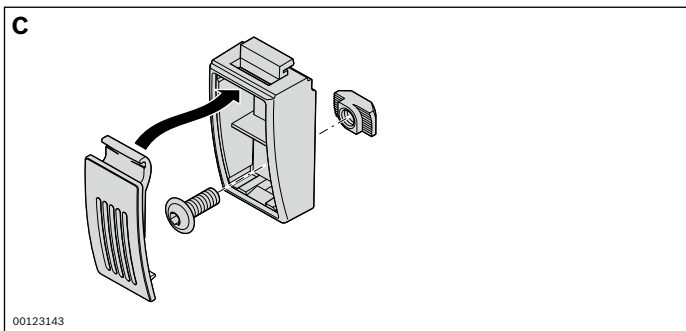

Lateral guide holder	No.
C	10 <b>3 842 531 552</b>

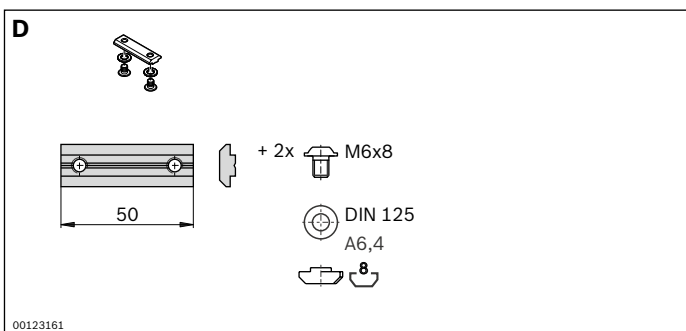

Profile connector	No.
D	10 <b>3 842 536 787</b>

8

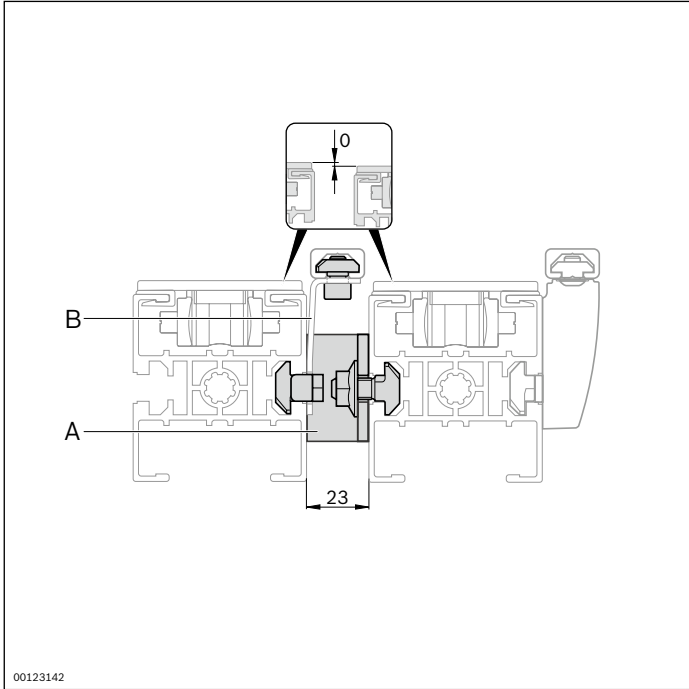

The middle lateral guide is used alternately by both sides. The section link (23 mm) **(A)** is used in combination with the holder for lateral guides (23 mm) **(B)** as a spacer between sections.

- The use of a section transfer (see page 244), diverter (see page 246) or junction (see page 254), requires parallel section spacing of 23 mm.

Material:

- **A, B:** Non-rusting steel
- Fastening parts: Galvanized steel

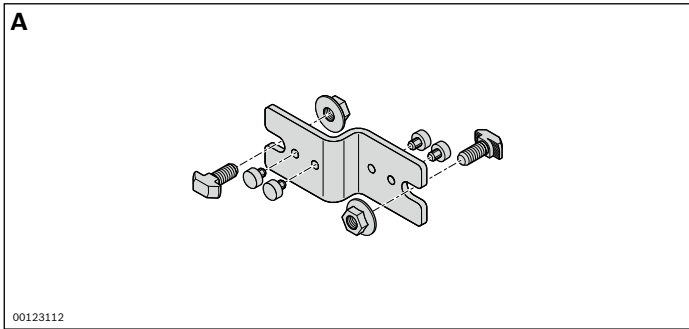

Section link	No.
A	10 3 842 532 998

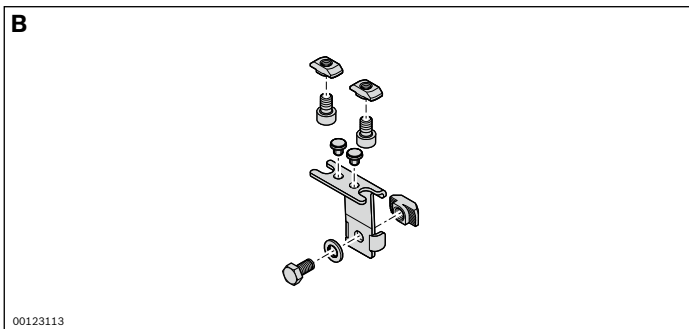

Lateral guide holder	No.
B	10 3 842 532 980



## Curve wheel lateral guide

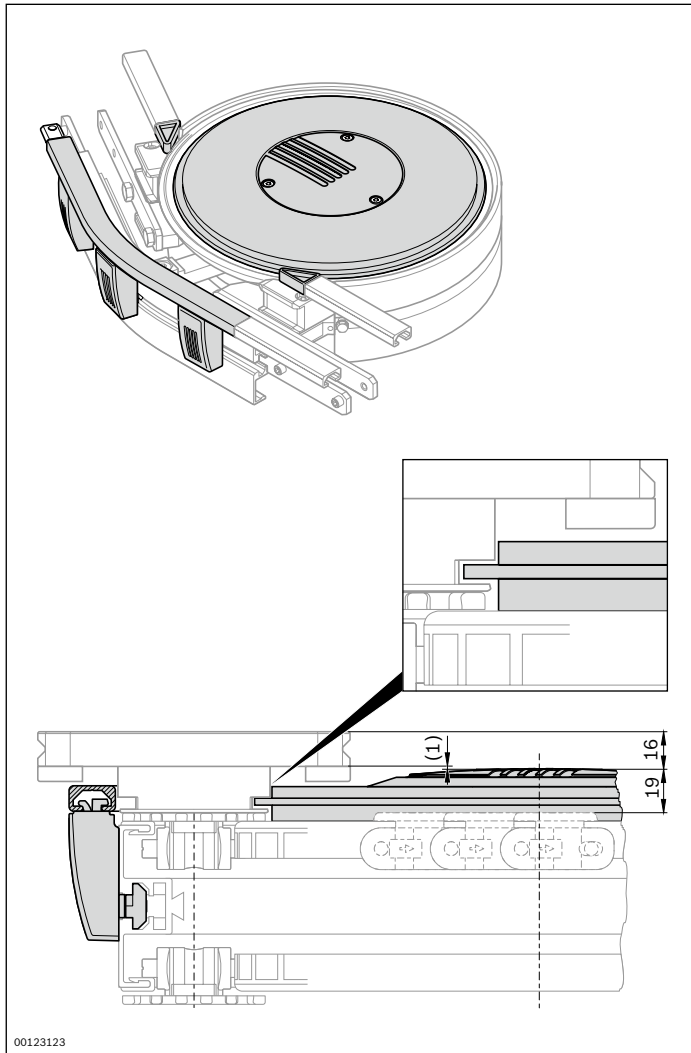

Lateral guide of the workpiece pallet (WT) in the curve wheel or curve wheel drive.

- Prevents the WT from ascending in accumulation operation or tipping over at high conveying speeds
- Complete kit for mounting on an existing curve wheel or curve wheel drive
- Lateral guide for curve wheels with other angles as well as lateral guide for curves available on request

Scope of delivery:

Kit incl. fastening parts (as shown)

Material:

- Guide rail: Aluminum; natural, anodized
- Guide disc, holder: PA, black
- Fastening parts: Galvanized steel

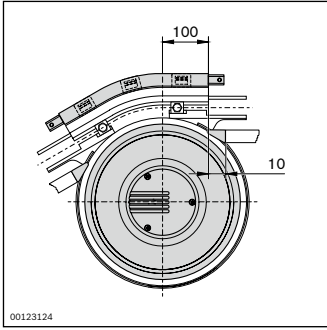

<b>Lateral guide 30°</b>	<b>No.</b>
VFplus 65	<b>3 842 547 949</b>
VFplus 90	<b>3 842 547 953</b>

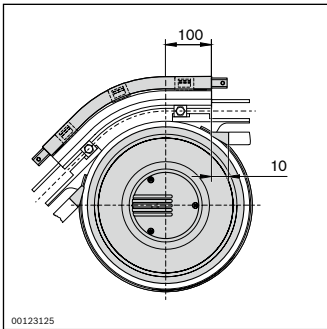

<b>Lateral guide 45°</b>	<b>No.</b>
VFplus 65	<b>3 842 547 950</b>
VFplus 90	<b>3 842 547 954</b>

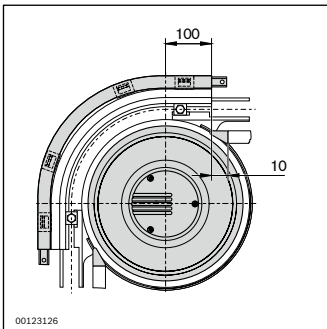

<b>Lateral guide 90°</b>	<b>No.</b>
VFplus 65	<b>3 842 547 951</b>
VFplus 90	<b>3 842 547 955</b>

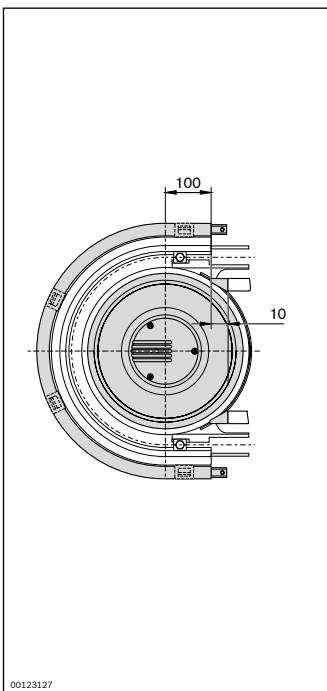

<b>Lateral guide 180°</b>	<b>No.</b>
VFplus 65	<b>3 842 547 952</b>
VFplus 90	<b>3 842 547 956</b>

# Stop gate VE 2/VF

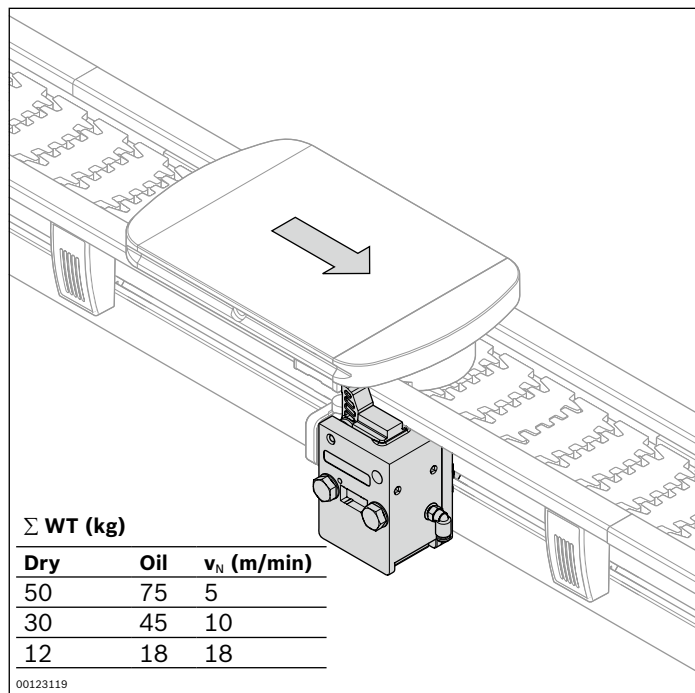

00123119

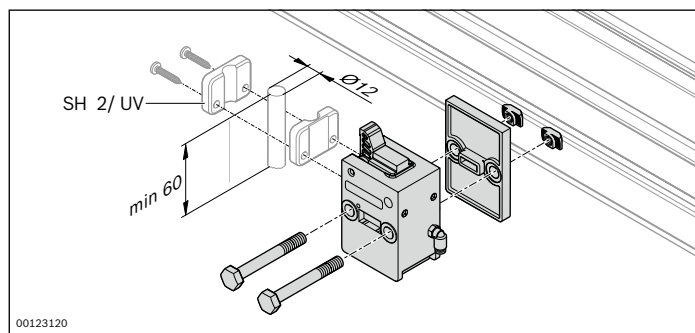

00123120

- Stop gate for securely stopping a workpiece pallet
- Suitable for retrofitting without disrupting the lateral guide
  - The stop gate can be installed in any position
  - Switch bracket for installation on stop gate see page 232, max. accumulation load 50 kg

Scope of delivery:  
Incl. fastening parts (as shown)

- Material:
- Stop gate: PA, black
  - Fastening parts: Galvanized steel

<b>VE 2/VF stop gate</b>	<b>No.</b>
	<b>3 842 528 852</b>



**Circuit diagram**

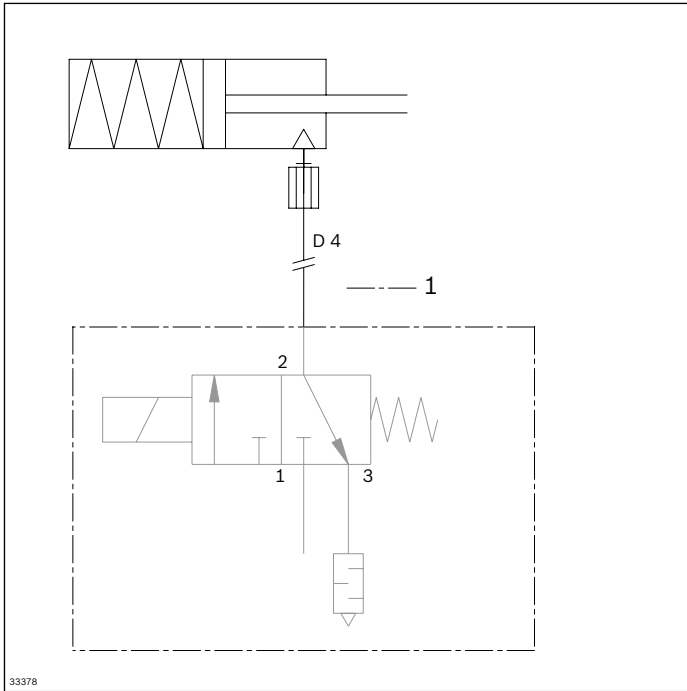

1 Not included in scope of delivery

## Return stop WT

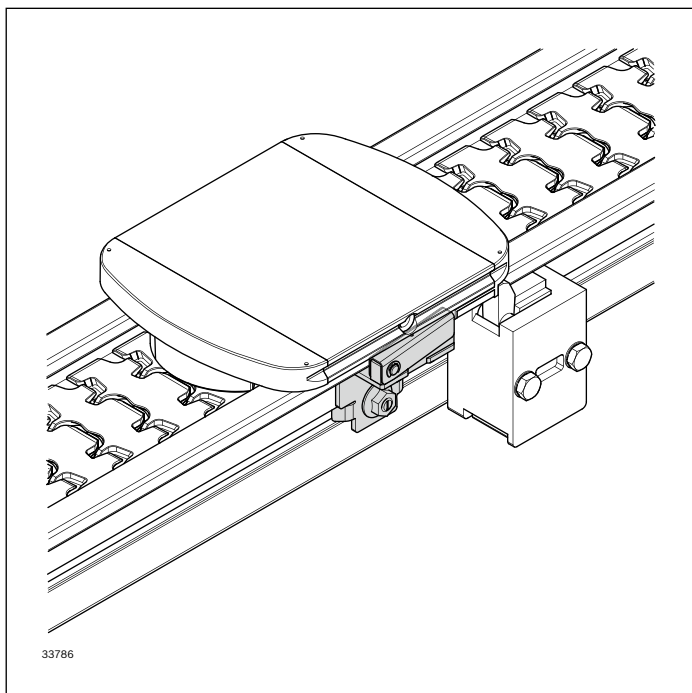

The return stop prevents the VarioFlow *plus* workpiece pallet from rebounding from the stop gate or prevents a backward movement of the workpiece pallet when the chain is turned off and released.

- Additional WT load max. 8 kg
- The return stop is attached behind the WT stop surface.

- ▶ Can be attached both left and right on the section profile
- ▶ Simple and low-cost construction

- ▶ Non-rotating
- ▶ Also suitable for retrofitting without disrupting the lateral guide

Scope of delivery:  
Incl. fastening material

Condition on delivery:  
Fully assembled

Material:  
Non-rusting steel 1.4301, galvanized steel, PA

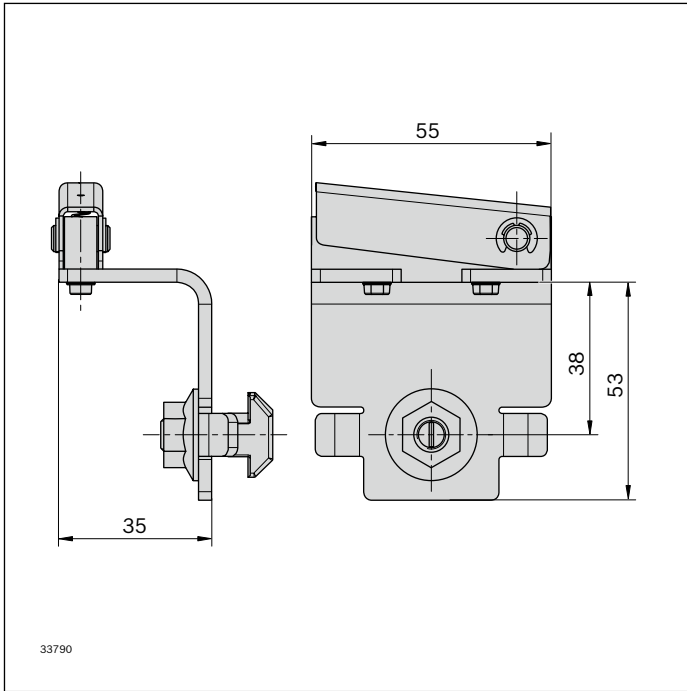

Return stop	No.
	3 842 553 090

## Position sensor accessories

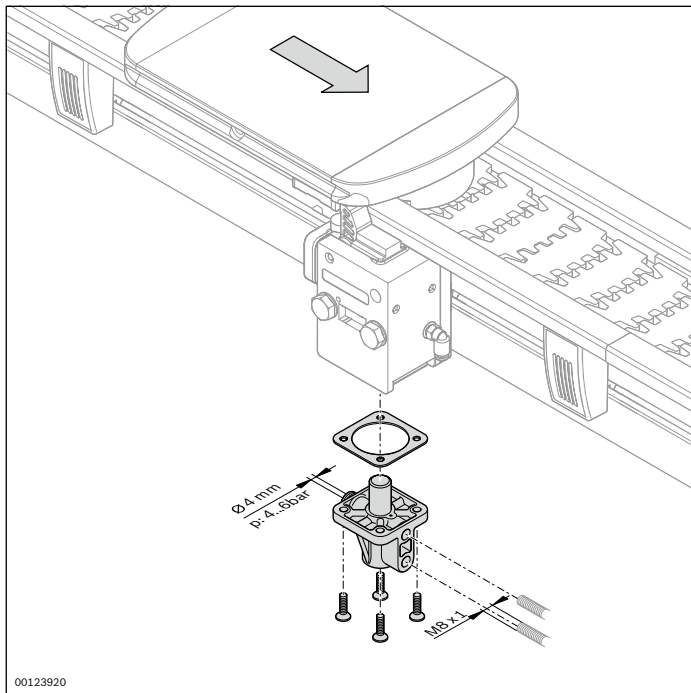

For querying the position of the stop gate via proximity switch and/or accelerating the pneumatic closing of the stop gate

- For retrofitting on the stop gate VE 2/VF

Required accessories:

Proximity switch M8x1 with switching distance  $S_N \geq 4$  mm

Material:

- Position sensor: PA, black
- Fastening parts: Galvanized steel

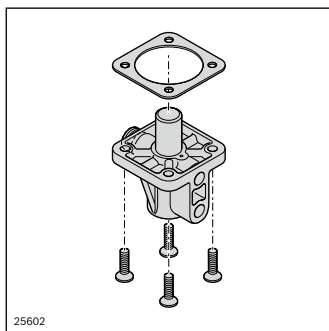

Position sensor	No.
	3 842 528 817

**Circuit diagram**

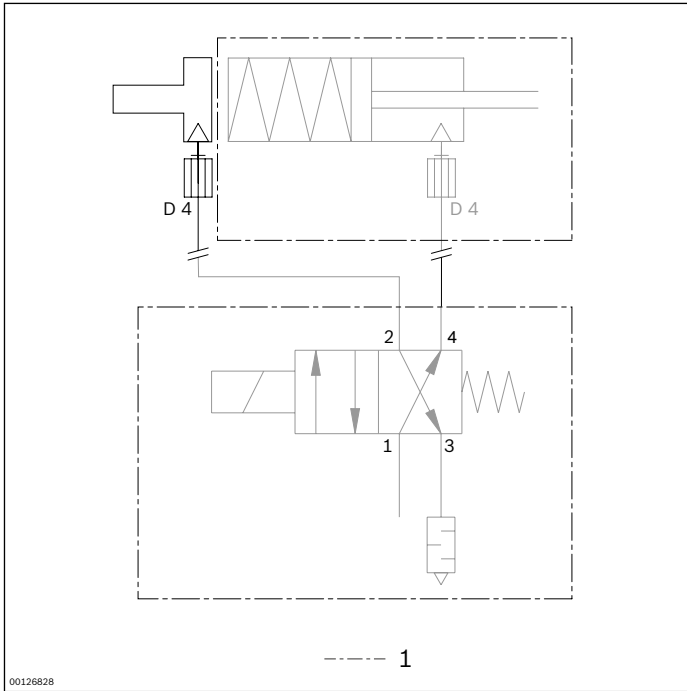

1 Not included in scope of delivery

## Switch bracket

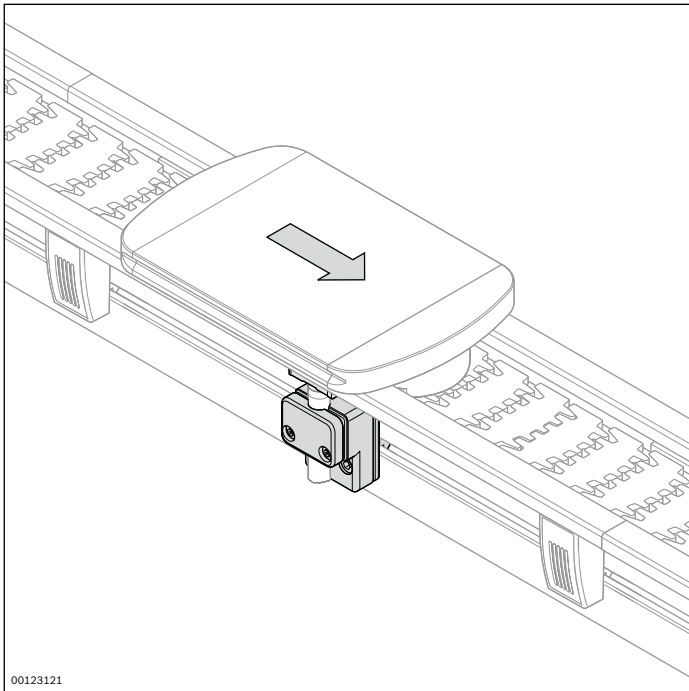

Switch bracket for a 12 mm proximity switch

- Suitable for subsequent installation without disrupting the lateral guide
- The switch bracket can be installed in any position

Scope of delivery:

Incl. fastening parts (as shown)

Material:

- Switch bracket: PA, black
- Fastening parts: Galvanized steel

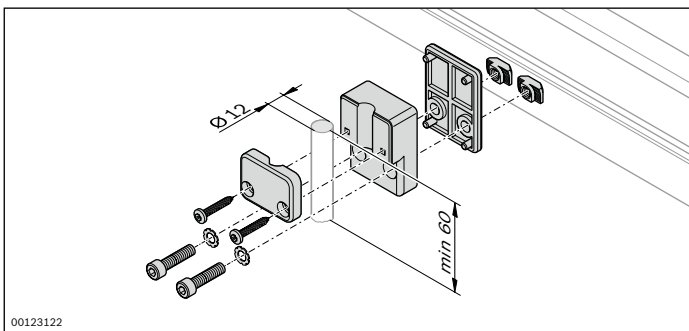

Switch bracket	No.
	3 842 531 355

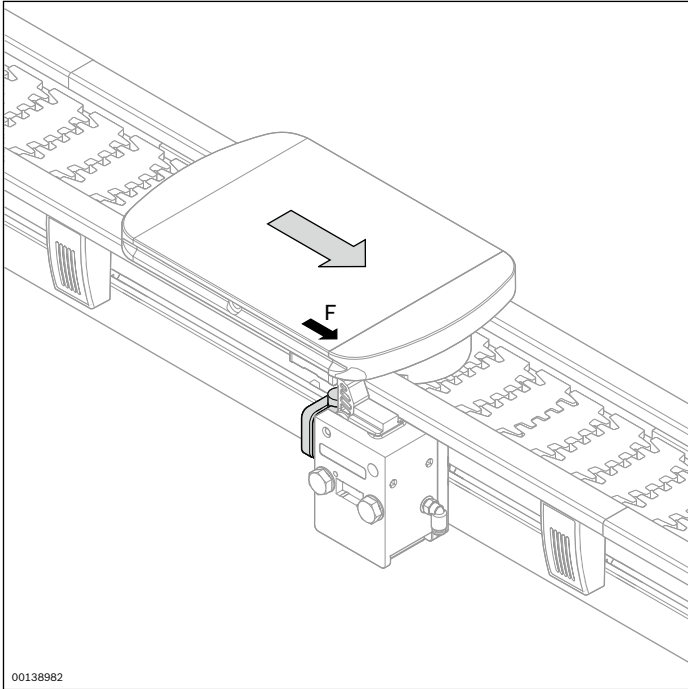

Switch bracket for a 12 mm proximity switch to install on stop gate VE 2/VF (see page 232)

- Can be attached to both sides of the VE 2/VF stop gate
- For querying the workpiece pallet position before and/or after the stop gate

Scope of delivery:  
Incl. fastening parts (as shown)

Material:

- Switch bracket: PA, black
- Fastening parts: Galvanized steel

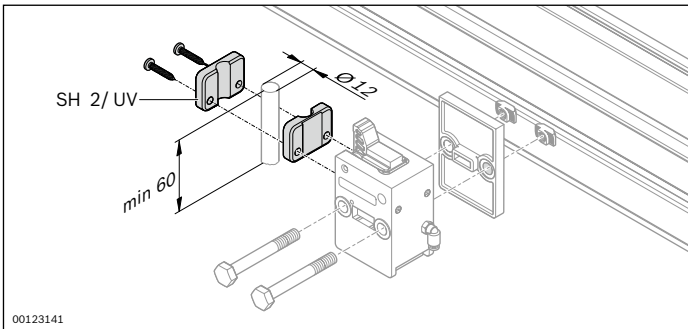

SH 2/UV switch bracket	No.
	3 842 168 600

## Positioning unit

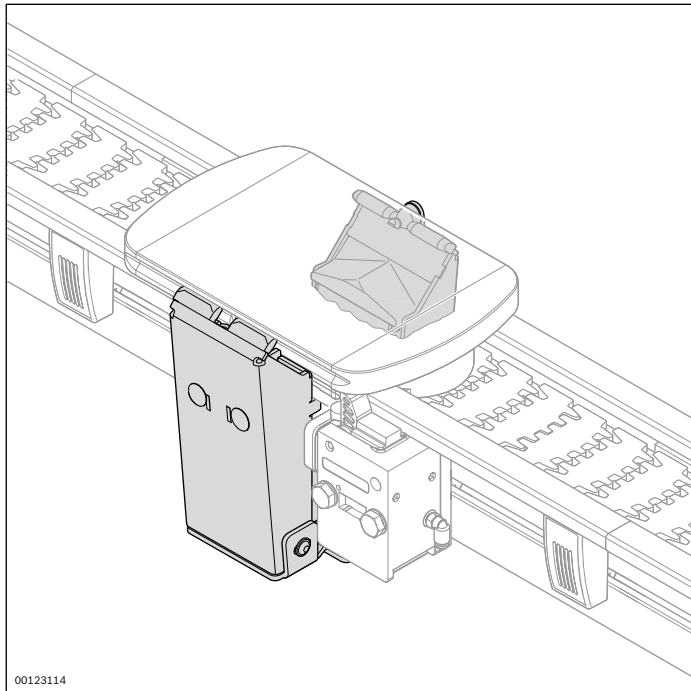

### Required accessories:

2 G 1/8" throttle non-return valves (not included in the scope of delivery)

### Scope of delivery:

Incl. fastening parts (as shown)

### Material:

- Positioning unit: stainless steel
- Fastening parts: Galvanized steel
- Cover caps: PA
- Clamping claws: PU

The plier-shaped form of the positioning unit (PE) makes it highly resistant to dirt and shavings and thus suitable for dirty environments. The WT is lifted approx. 1 mm above the transport surface, thus eliminating the load on the conveyor chain during processing.

- Positioning accuracy in the conveying direction:  $\pm 0.15$  mm (across:  $\pm 0.1$  mm, height:  $\pm 0.1$  mm)
- Maximum vertical press force ( $p = 4$  bar): 400 N
- Maximum retention force ( $p = 4$  bar) in the conveying direction: 300 N
- Suitable for retrofitting without disrupting the lateral guide
- The switch bracket can be installed in any position
- Minimum length of the workpiece pallet in order to incorporate the positioning unit:
  - Size 65: L = 125 mm
  - Size 90: L = 125 mm
- Two positioning units can be combined for workpiece pallets with  $L > 250$  mm. For this, the position mandrel is removed from one of the PEs and the workpiece pallets are fitted with eccentric centering bushings by the customer.
- Position inquiry with assembly kit and 2 M12x1 proximity switches on the housing (proximity switches not in the scope of delivery) or with **3 842 535 150** on the cylinder



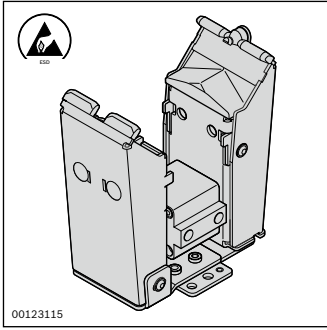

Positioning unit	No.
	3 842 532 762

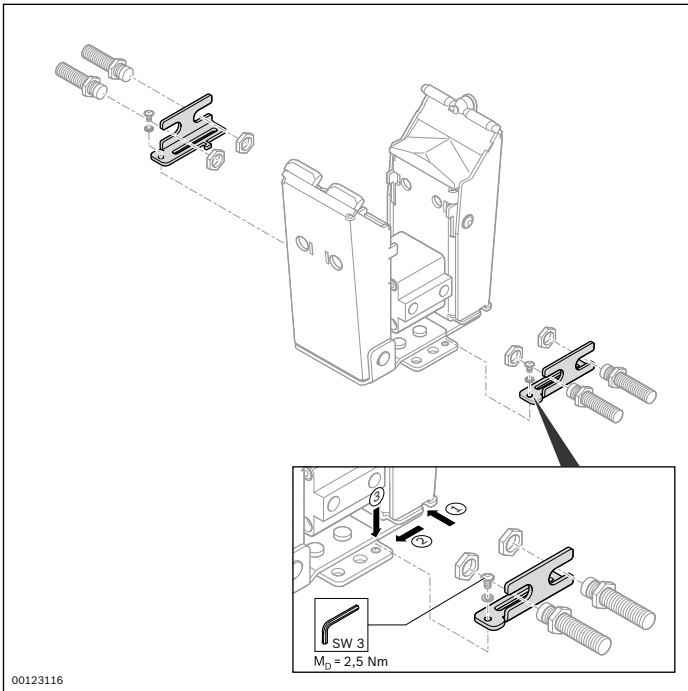

Position monitoring kit	No.
	3 842 535 801

8

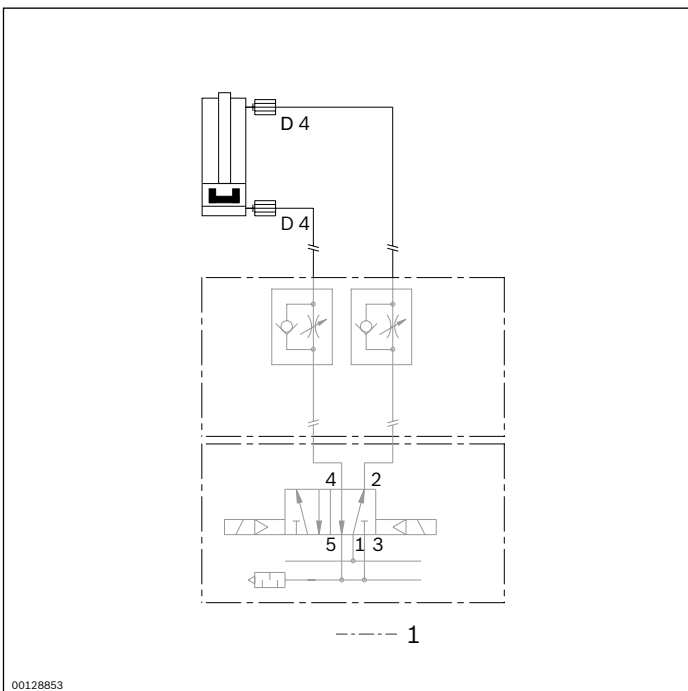

**Circuit diagram**

1 Not included in scope of delivery

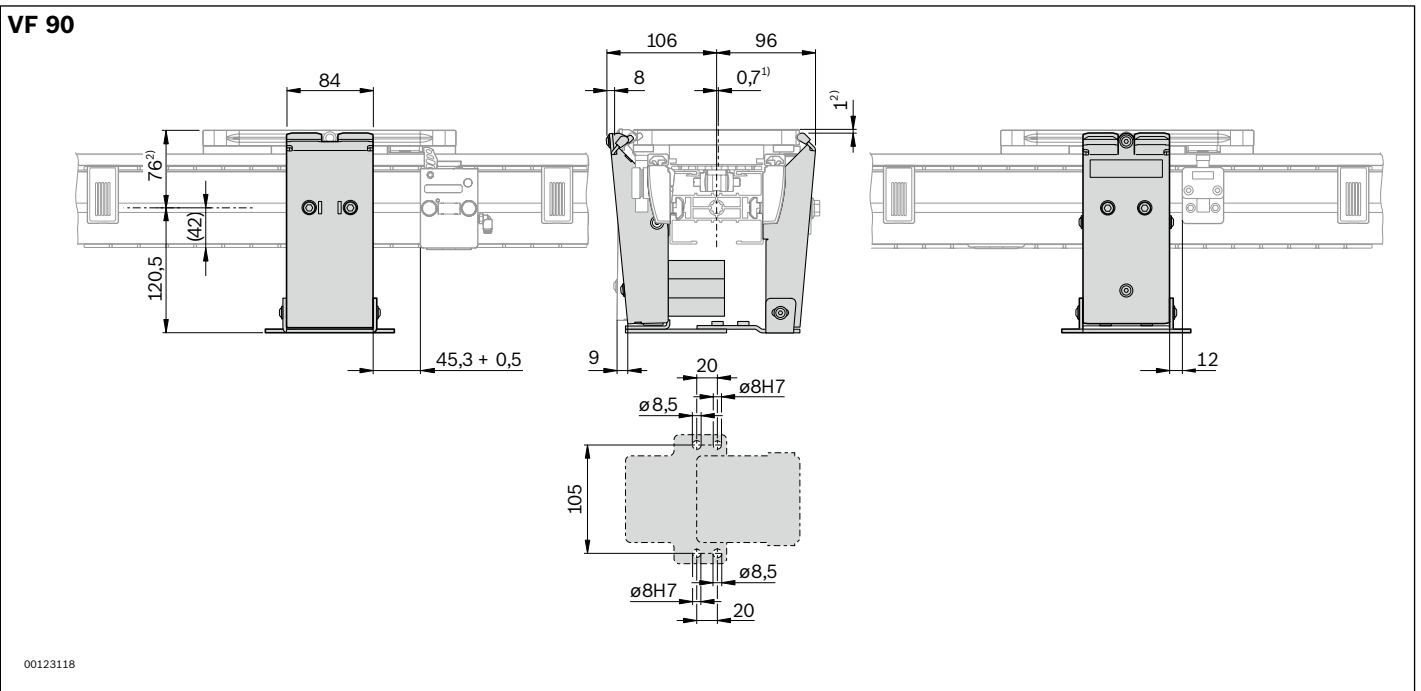
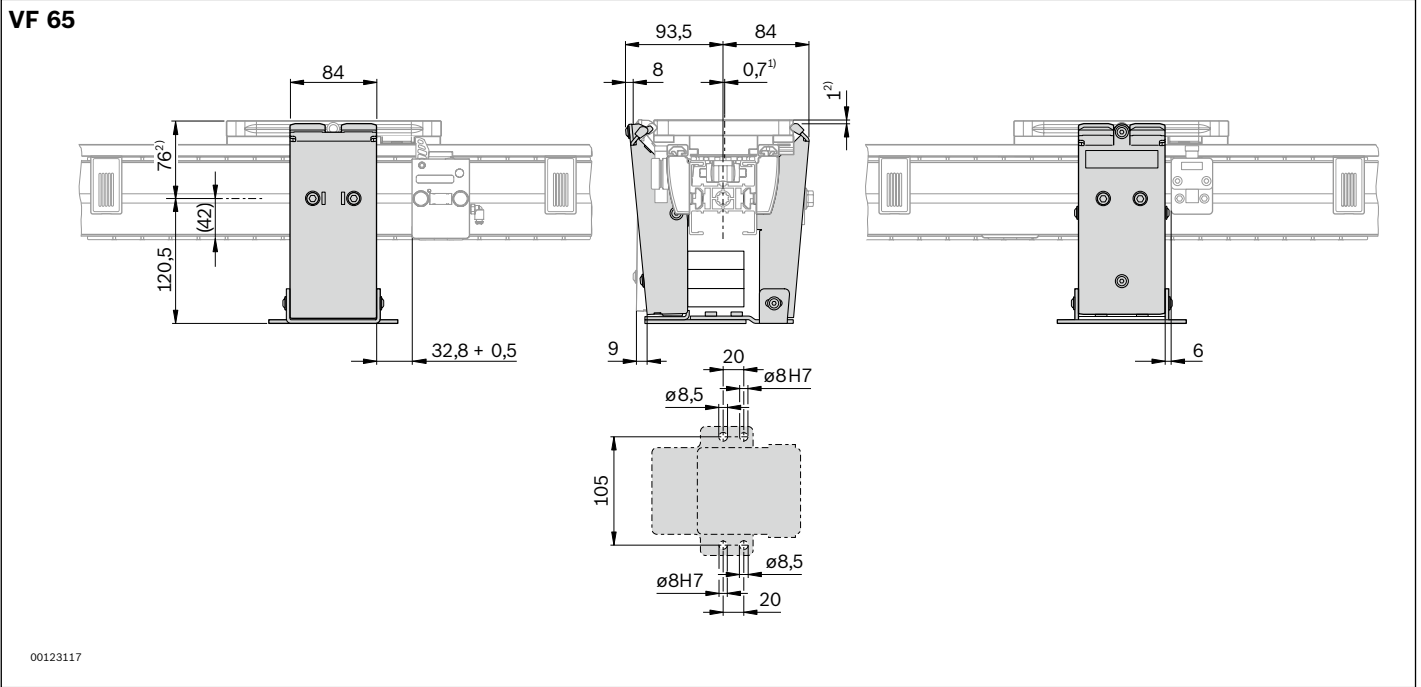

<sup>1)</sup> Center offset of the workpiece pallet when it is positioned

<sup>2)</sup> Height offset of the workpiece pallet when it is positioned.



## Section transfer

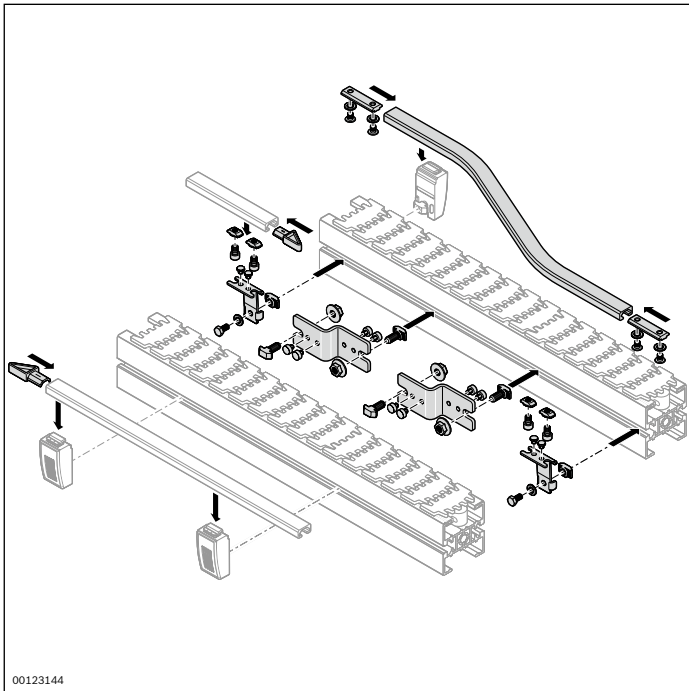

Assembly kit for a simple track change between two straight, parallel conveyor sections

Material:

- Guide rail: Aluminum; natural, anodized
- Section link, holder: stainless steel
- Fastening parts: steel; galvanized
- End caps: PA; black

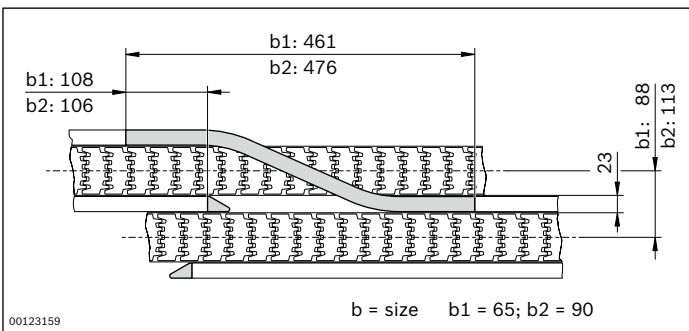

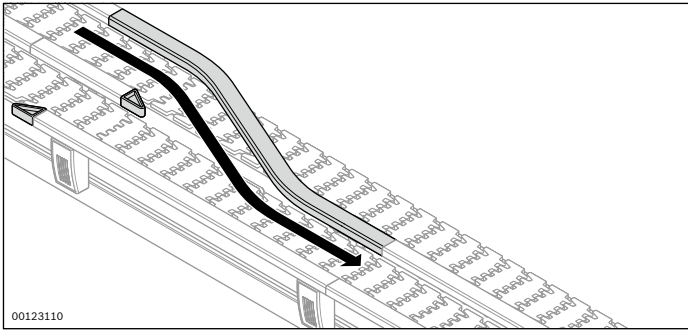

<b>Section transfer, right</b>	<b>No.</b>
VFplus 65	<b>3 842 535 003</b>
VFplus 90	<b>3 842 535 001</b>

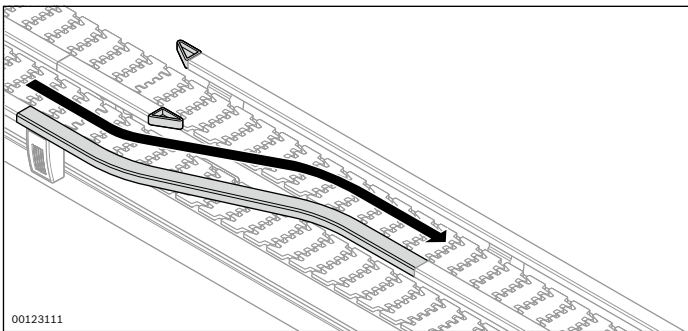

<b>Section transfer, left</b>	<b>No.</b>
VFplus 65	<b>3 842 535 004</b>
VFplus 90	<b>3 842 535 002</b>

## Diverter

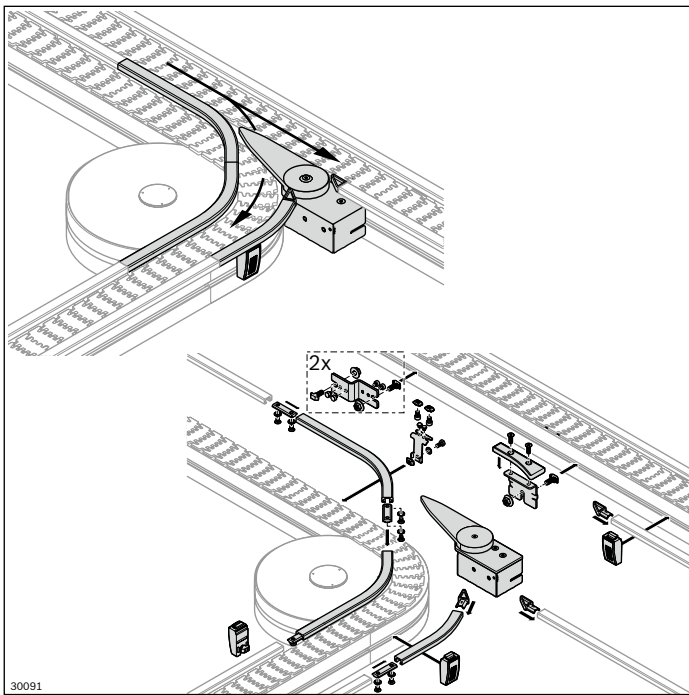

For optionally changing tracks between different, curving conveyor sections

- Complete assembly kit to install on existing sections or curve wheels
- The support enables the workpiece pallet to move safely over the section gap with no danger of tipping.  
No accumulation operation against the diverter blade!

Required accessories:

2 G 1/8" throttle non-return valves (not included in the scope of delivery)

Scope of delivery:

Kit incl. Fastening parts (as shown)

Material:

Diverter blade, gliding surface support: PA; black

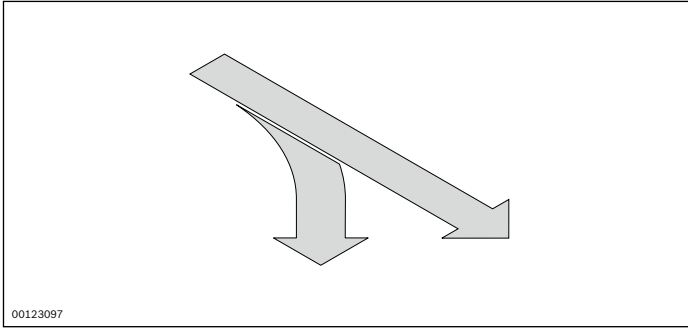

<b>45° diverter, right</b>	<b>No.</b>
<i>VFplus 65</i>	<b>3 842 551 104</b>
<i>VFplus 90</i>	<b>3 842 551 090</b>

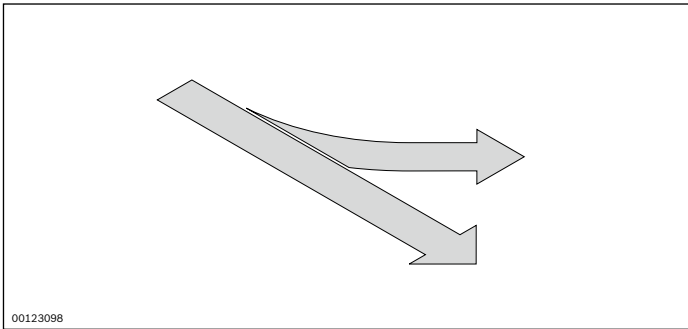

<b>45° diverter, left</b>	<b>No.</b>
<i>VFplus 65</i>	<b>3 842 551 105</b>
<i>VFplus 90</i>	<b>3 842 551 091</b>

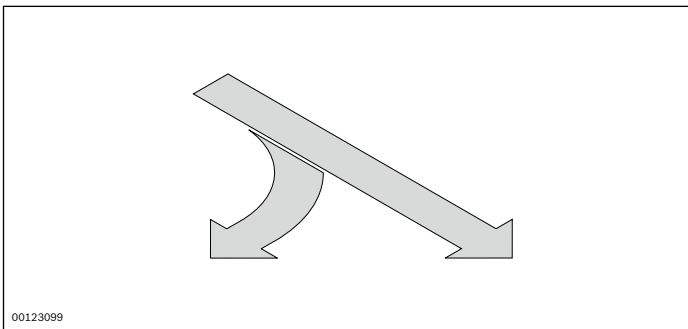

<b>90° diverter, right</b>	<b>No.</b>
<i>VFplus 65</i>	<b>3 842 551 111</b>
<i>VFplus 90</i>	<b>3 842 551 110</b>

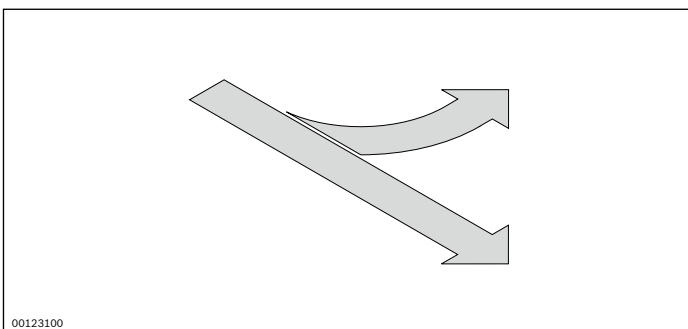

<b>90° diverter, left</b>	<b>No.</b>
<i>VFplus 65</i>	<b>3 842 551 121</b>
<i>VFplus 90</i>	<b>3 842 551 110</b>

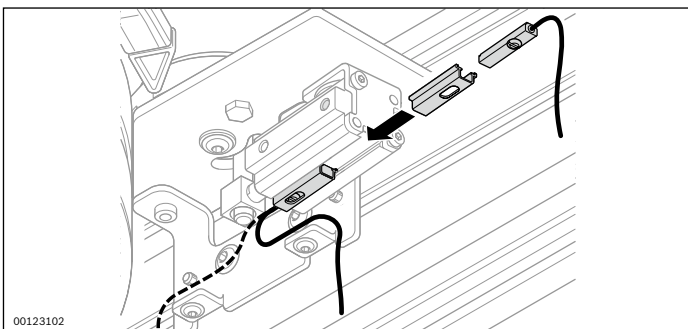

<b>Position sensor diverter</b>	<b>No.</b>
	<b>3 842 535 150</b>

**Circuit diagram**

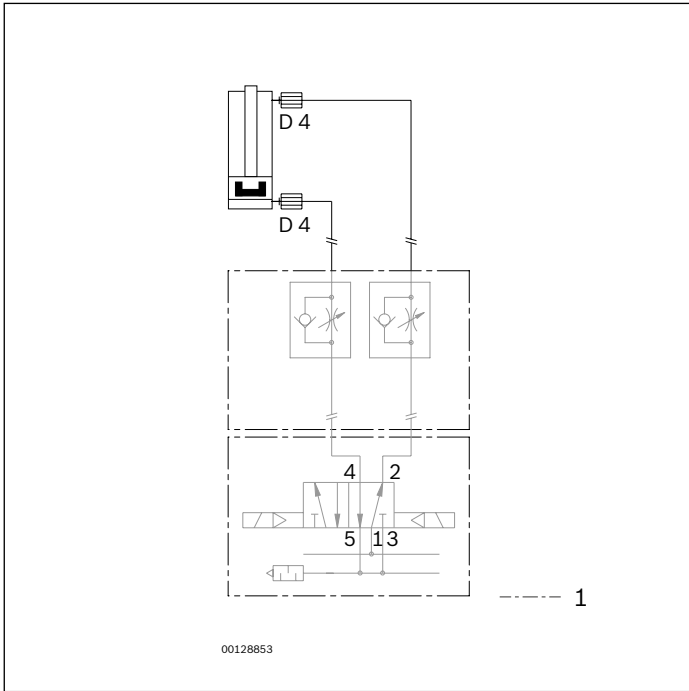

1 Not included in scope of delivery



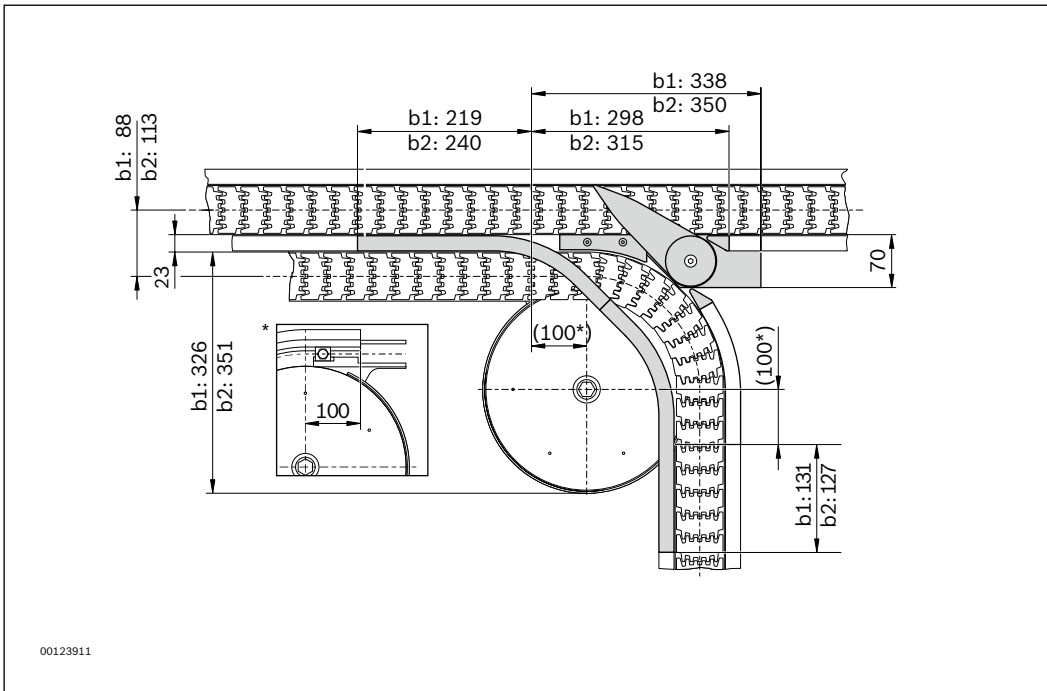
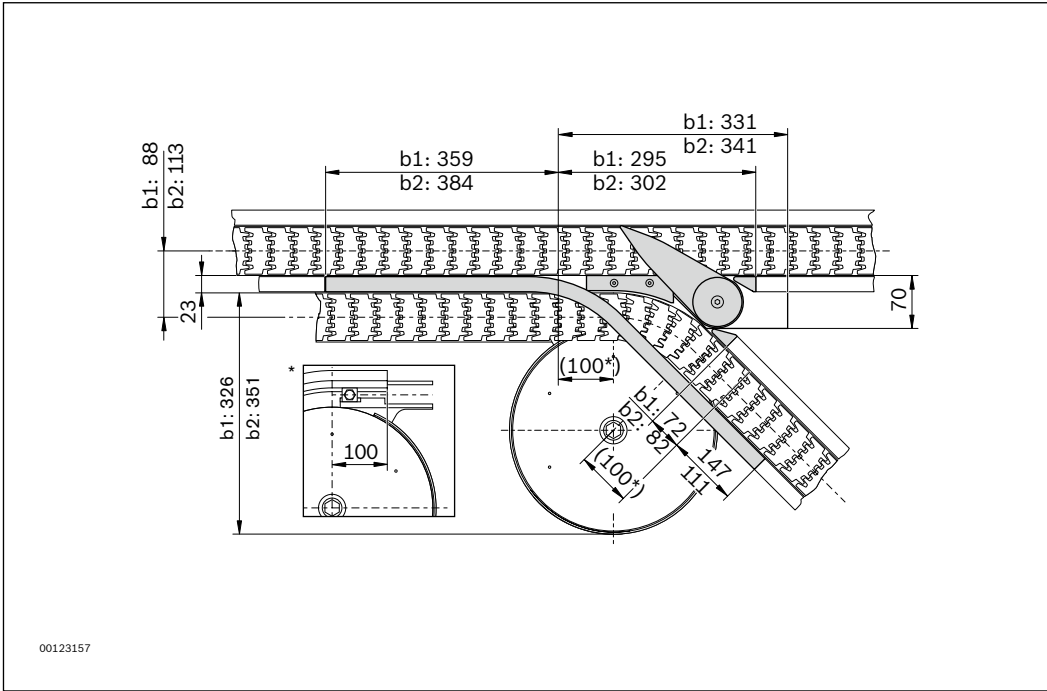

b = size  
 b1 = 65; b2 = 90

## Cross-diverter

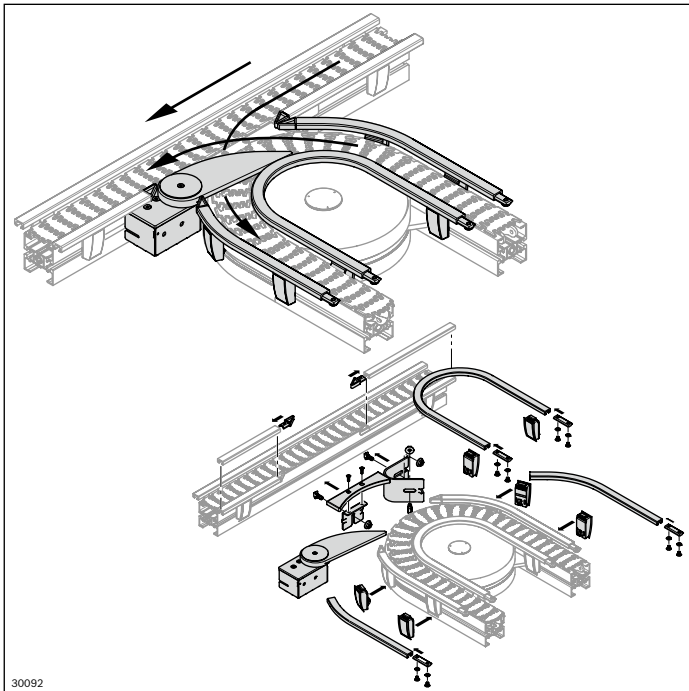

The cross-diverter combines the functions of junctions and diverters in a compact construction.

- Complete assembly kit to install on existing sections or curve wheels
- For problem-free section transfer, the center of gravity for the load must be in the center of the optimal range (see page 222)
- Permitted speed range: min. 4 m/min, max. 18 m/min
- The support enables the workpiece pallet to move safely over the section gap with no danger of tipping.  
No accumulation operation against the diverter blade!

Scope of delivery:

Kit incl. fastening parts (as shown)

Material:

Diverter blade, gliding surface support: PA; black

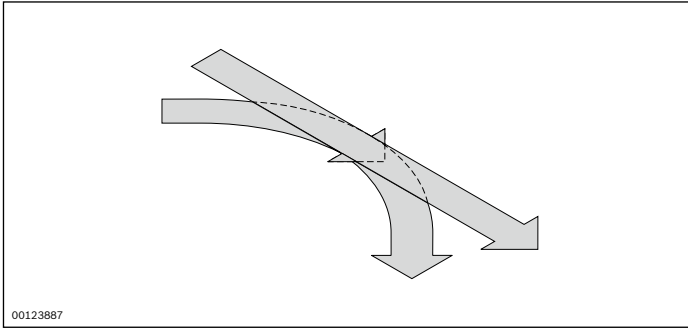

<b>45° cross-diverter, right</b>	<b>No.</b>
<i>VFplus 65</i>	<b>3 842 551 086</b>
<i>VFplus 90</i>	<b>3 842 551 084</b>

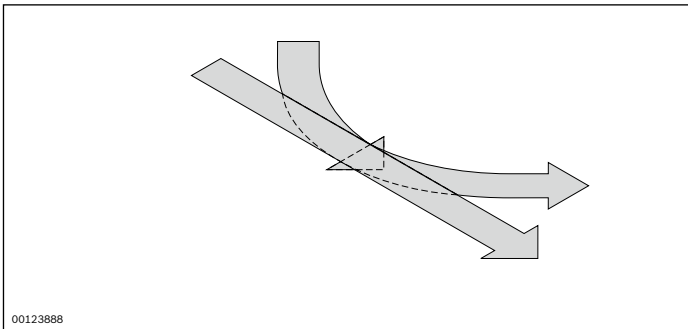

<b>45° cross-diverter, left</b>	<b>No.</b>
<i>VFplus 65</i>	<b>3 842 551 140</b>
<i>VFplus 90</i>	<b>3 842 551 139</b>

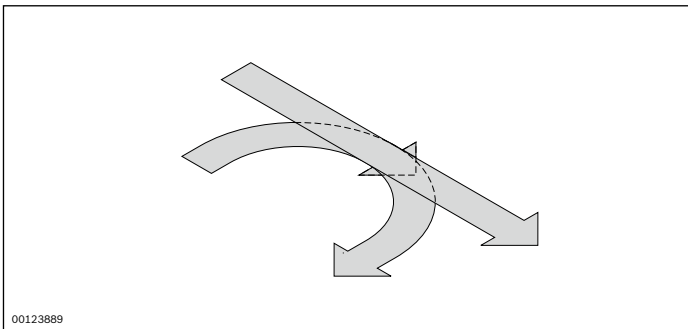

<b>90° cross-diverter, right</b>	<b>No.</b>
<i>VFplus 65</i>	<b>3 842 551 108</b>
<i>VFplus 90</i>	<b>3 842 551 074</b>

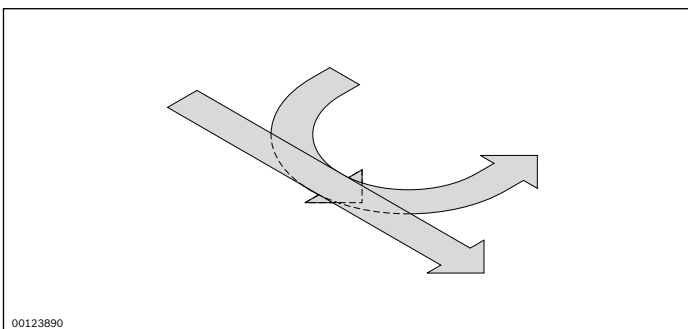

<b>90° cross-diverter, left</b>	<b>No.</b>
<i>VFplus 65</i>	<b>3 842 551 141</b>
<i>VFplus 90</i>	<b>3 842 551 138</b>

Circuit diagram

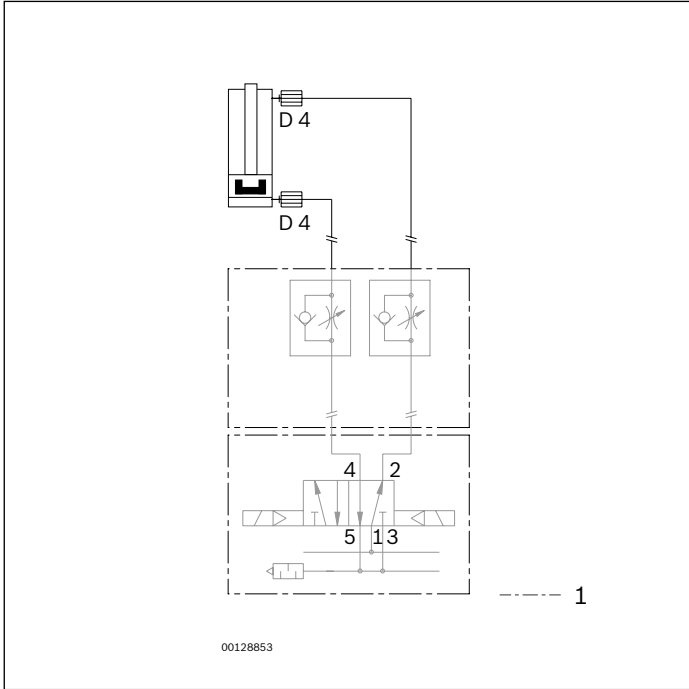

1 Not included in scope of delivery

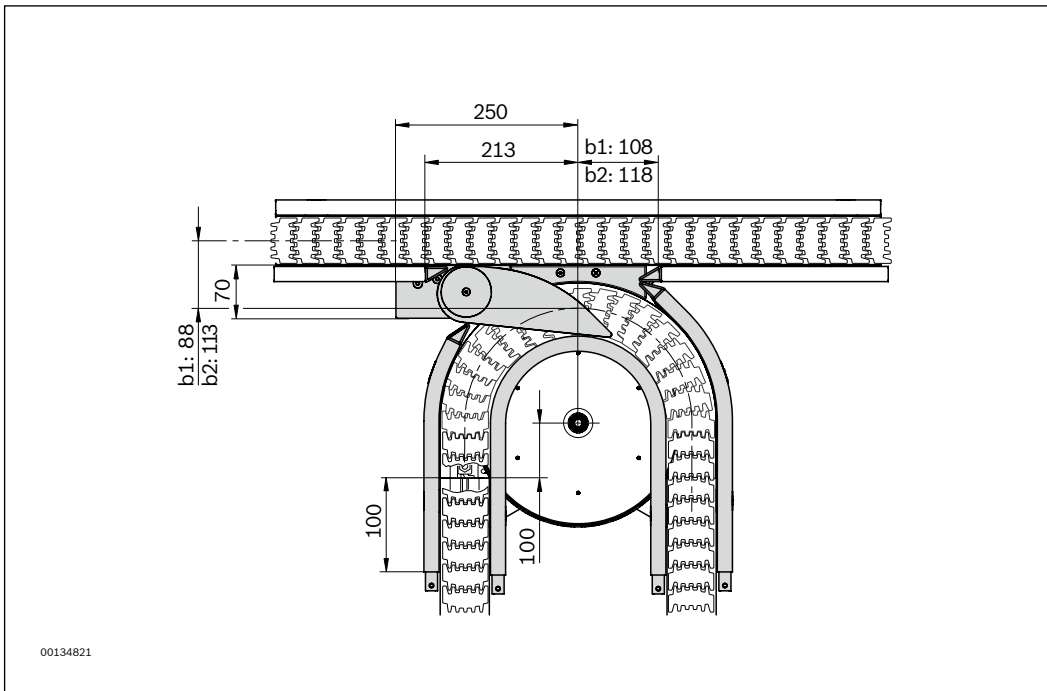
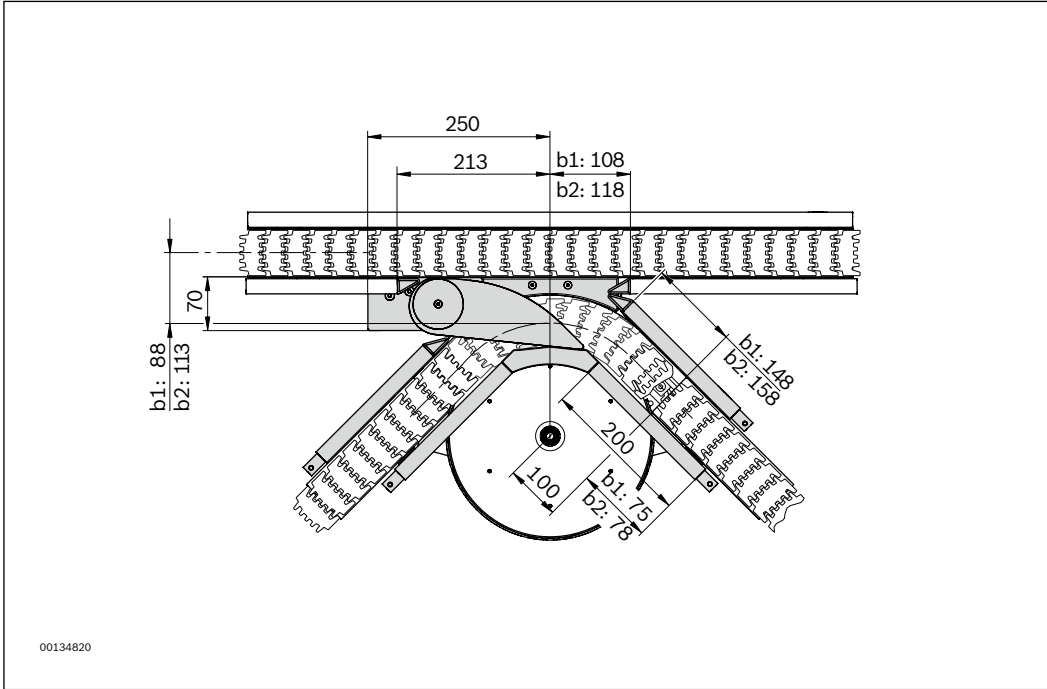

b = size  
b1 = 65; b2 = 90

## Junction

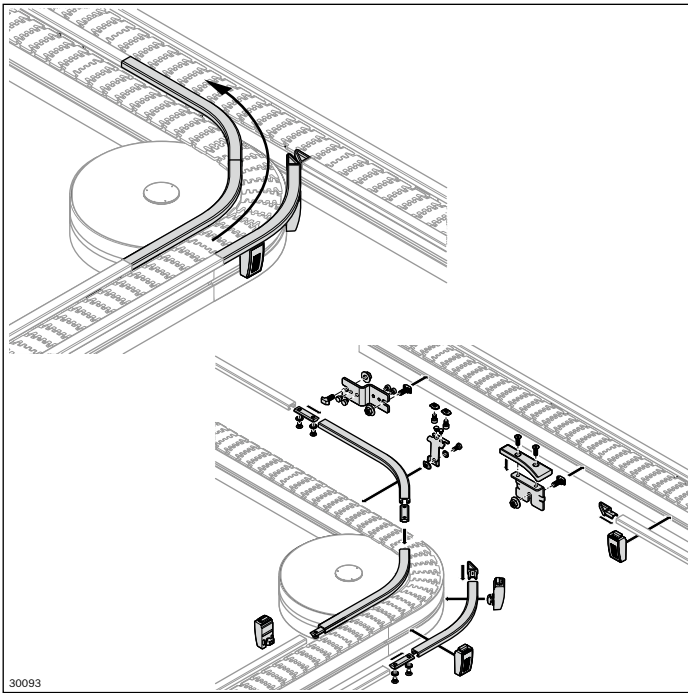

Used for the junction of different, curving conveyor sections

- Complete assembly kit to install on existing sections or curve wheels
- The support enables the workpiece pallet to move over the section gap with no danger of tipping

Scope of delivery:

Kit incl. fastening parts (as shown)

Material:

Gliding surface support: PA; black

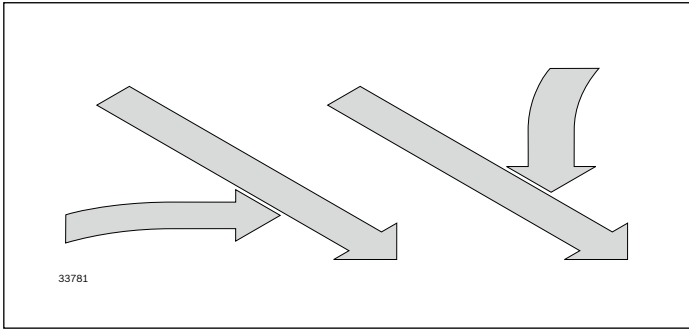

<b>45° junction, right/left</b>	<b>No.</b>
<i>VFplus 65/90</i>	<b>3 842 551 122</b>

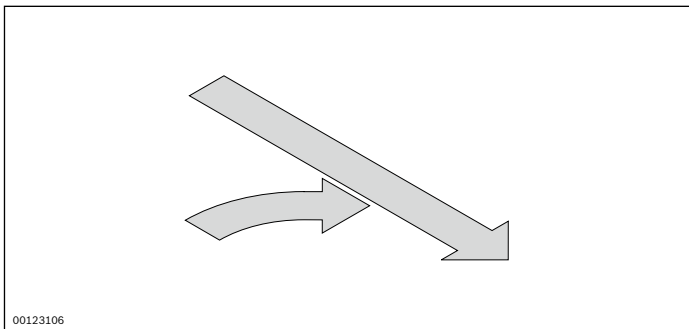

<b>90° junction, right</b>	<b>No.</b>
<i>VFplus 65</i>	<b>3 842 551 128</b>
<i>VFplus 90</i>	<b>3 842 551 125</b>

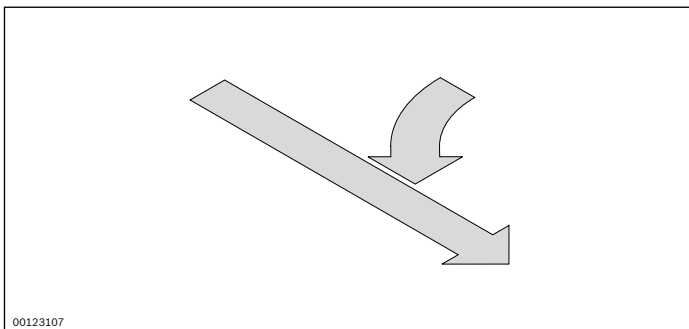

<b>90° junction, left</b>	<b>No.</b>
<i>VFplus 65</i>	<b>3 842 551 137</b>
<i>VFplus 90</i>	<b>3 842 551 124</b>

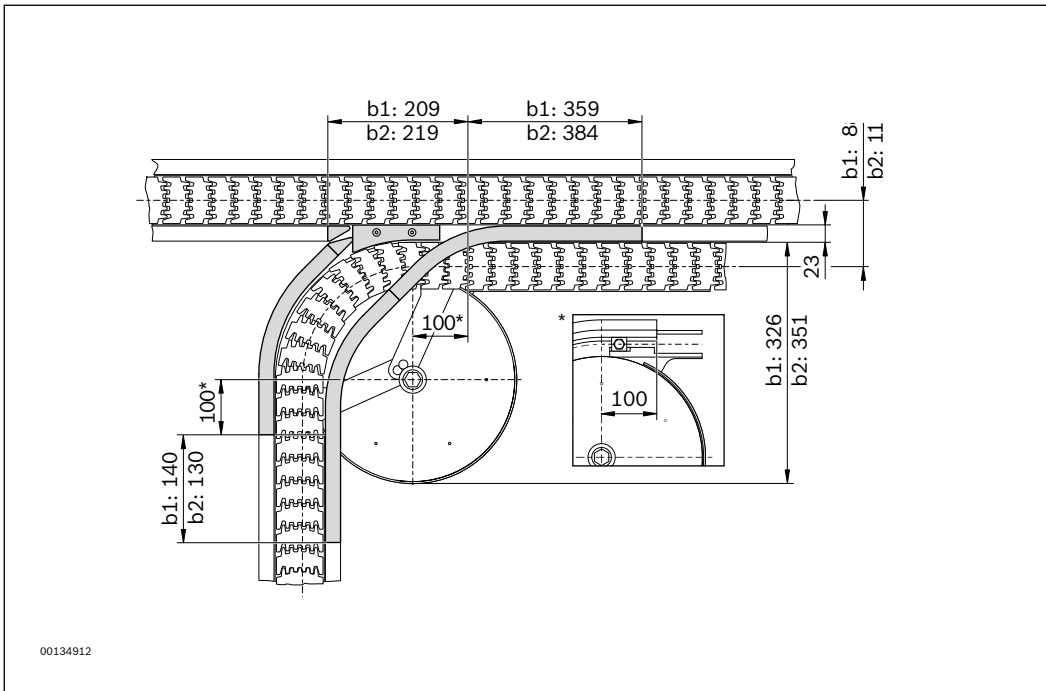
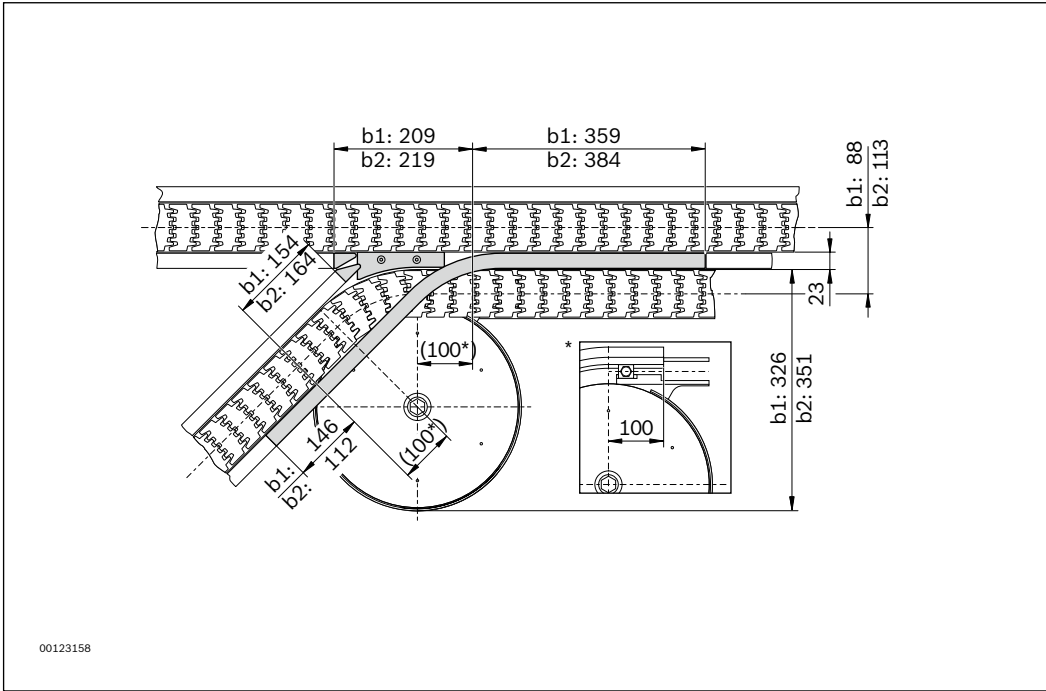

b = size;  
b1 = 65; b2 = 90





## Rocker WT system

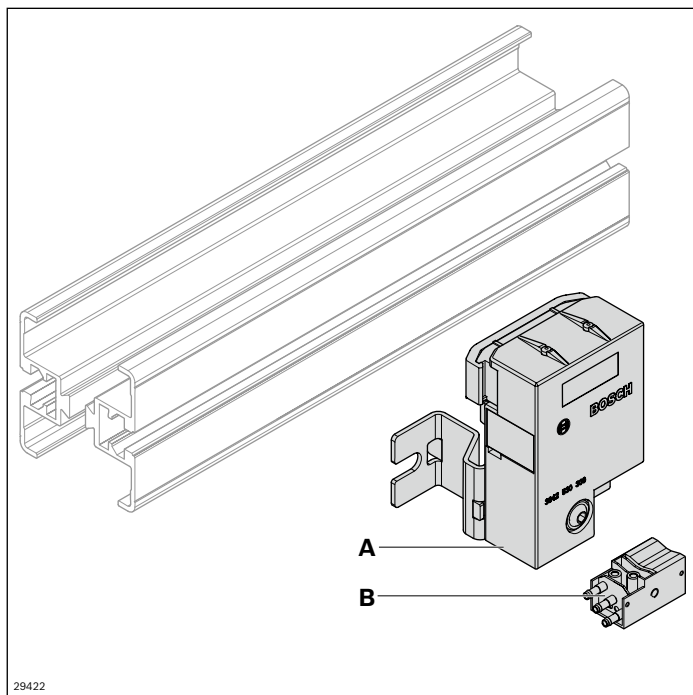

The rocker can be used for area monitoring, regulating accumulation pressure, and workpiece pallet recognition. A query can be either made electrically with a proximity switch or pneumatically to convert the shutter actuation directly into a pneumatic signal. Simple, purely pneumatic accumulation pressure regulation can be established in conjunction with a stop gate VE 2/VF.

- Monitoring range: 60 mm

- ▶ The rocker does not protrude beyond the top edge of the workpiece pallet
- ▶ A sideways query on the workpiece pallet plate ensures that the lateral guide profiles are not interrupted

### Accessories:

- Pneumatic cylinder switch **(B)** (3 842 532 151)
- 12 mm proximity switch, round with switching distance  $S_N > 4$  mm

### Scope of delivery:

Set incl. fastening material

### Condition on delivery:

Partially assembled

### Material:

Stainless steel, PA

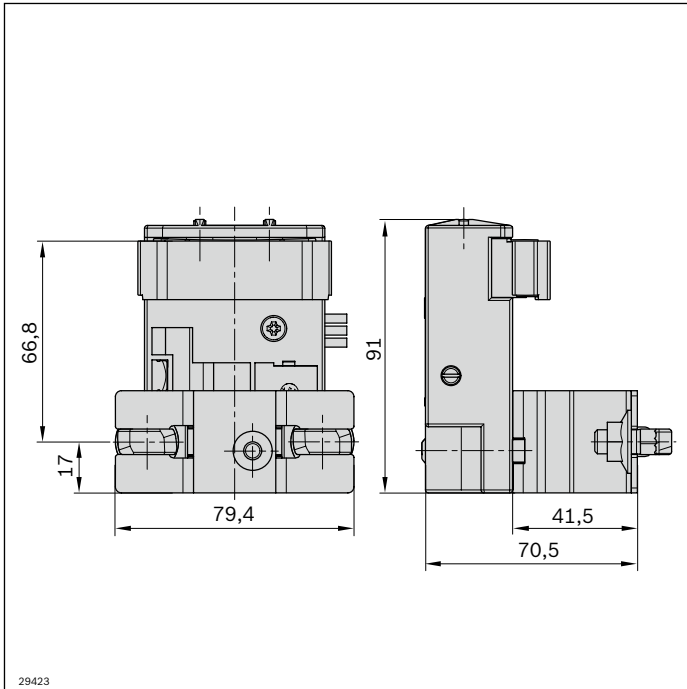

Rocker		No.
A	1 pcs	3 842 547 464

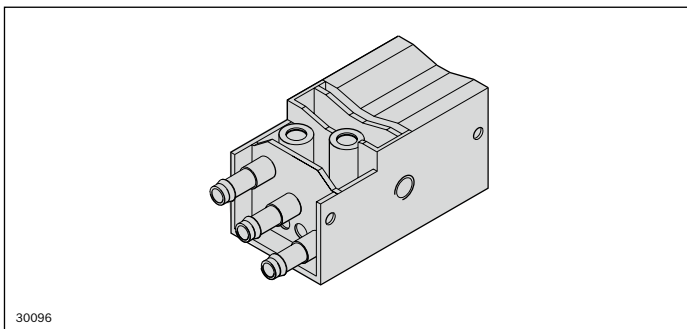

Pneumatic cylinder switch		No.
B	1 pcs	3 842 532 151

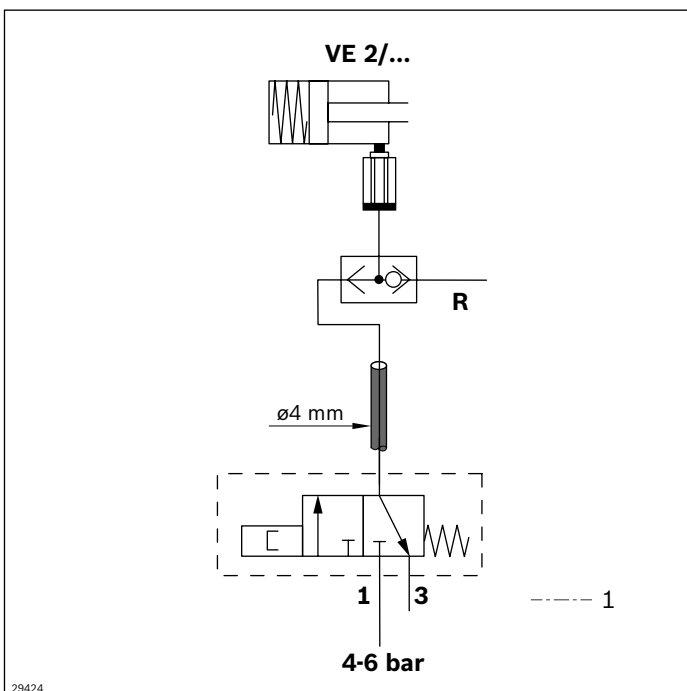

**Circuit diagram**

1 Not included in scope of delivery

## Identification systems ID 15 and ID 200

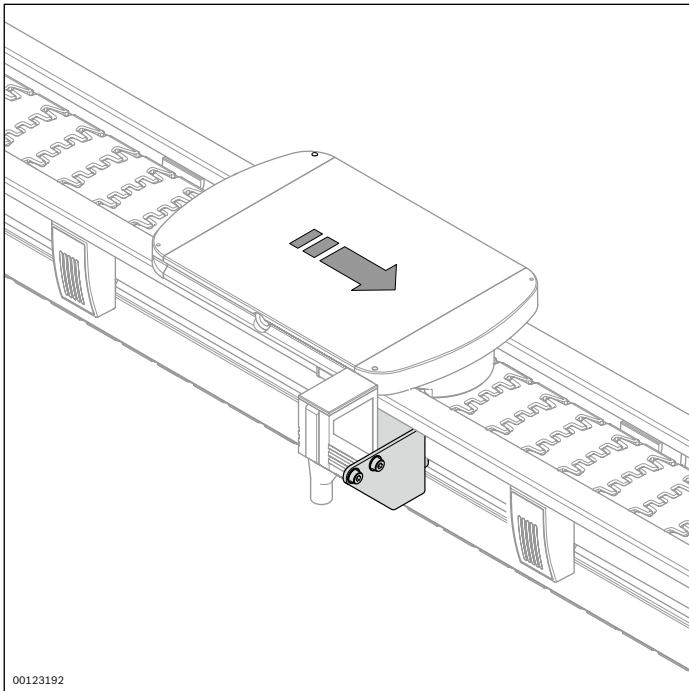

Assembly kits and mobile data tags for identification systems ID 15 and ID 200 for use in VarioFlow *plus* systems can be found in the RFID systems catalog (3 842 541 003).





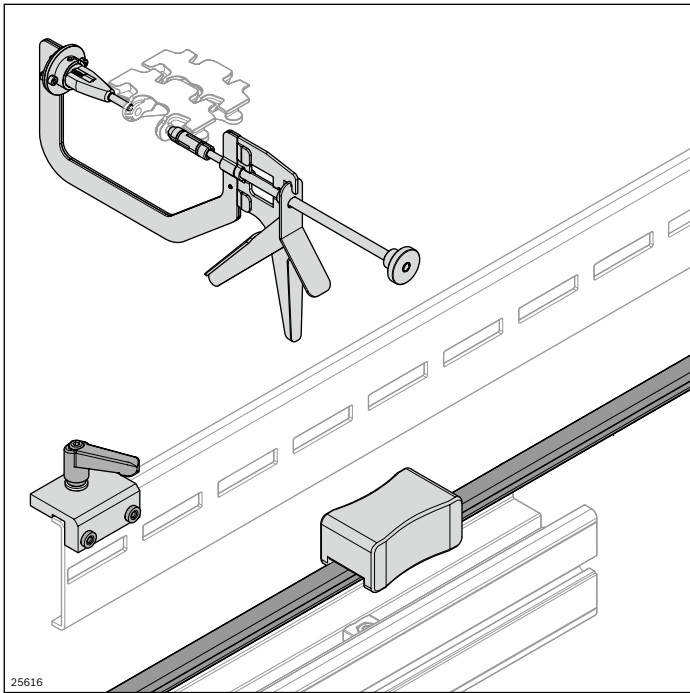

00123192



# Tools



Convenient assembly with the appropriate tool

	<b>Chain assembly tool</b>	<b>264</b>
	<b>Slide rail assembly tool</b>	<b>264</b>
	<b>Drilling jig</b>	<b>265</b>
	<b>Miter cutter</b>	<b>265</b>
	<b>Safety coupling tool</b>	<b>265</b>
	<b>Bending tool for lateral guide</b>	<b>266</b>

## Chain assembly tool

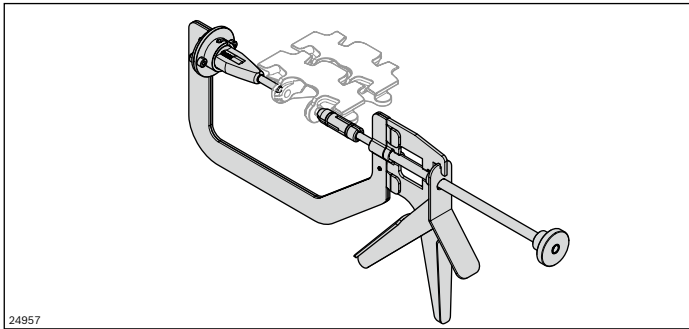

Assembly tool for inserting and removing the chain pin at an easily accessible place, e.g. chain bag, assembly module.

---

**Chain assembly tool**

**No.**

**3 842 549 835**

---

## Slide rail assembly tool

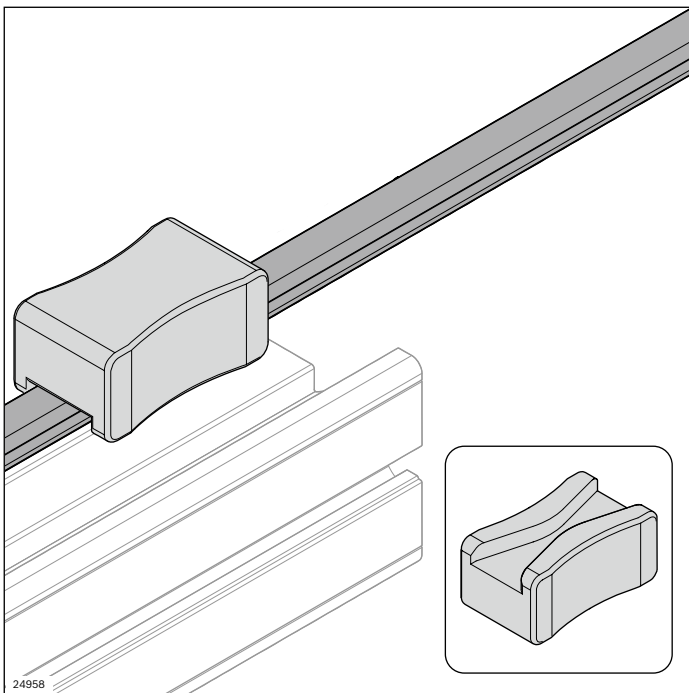

Assembly tool to easily and effortlessly clip the slide rail onto the section profile

---

**Slide rail assembly tool**

**No.**

**3 842 549 738**

---



# Drilling jig

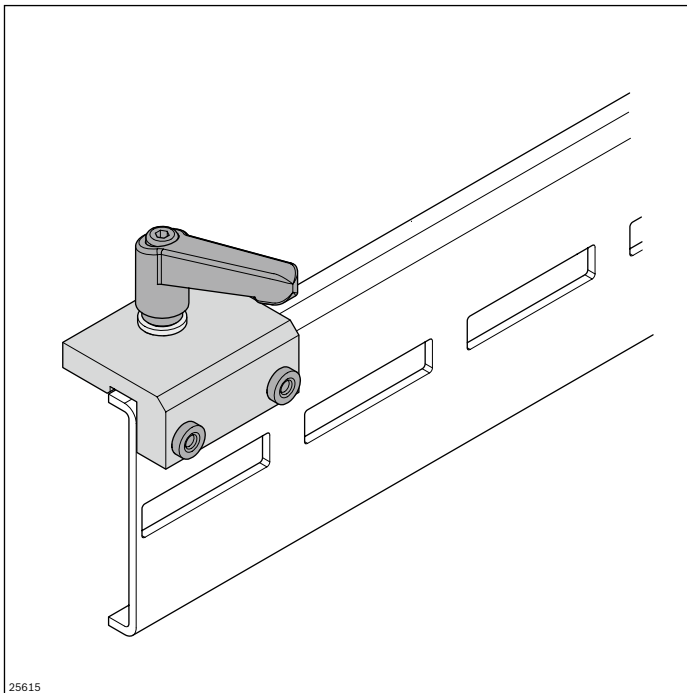

25615

The drilling jig can be right- or left-justified and is used to drill an accurately positioned hole to secure the slide rail both on the section profile as well as on the support profile.

Drilling jig	No.
	3 842 553 518

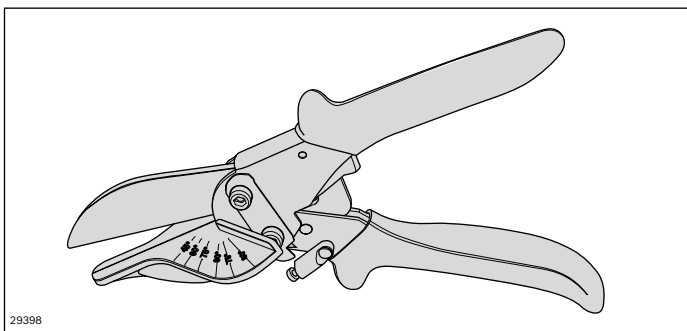

29398

The slide rail can be easily and quickly cut to the correct length and angle with the miter cutter.

Miter cutter	No.
	3 842 547 982

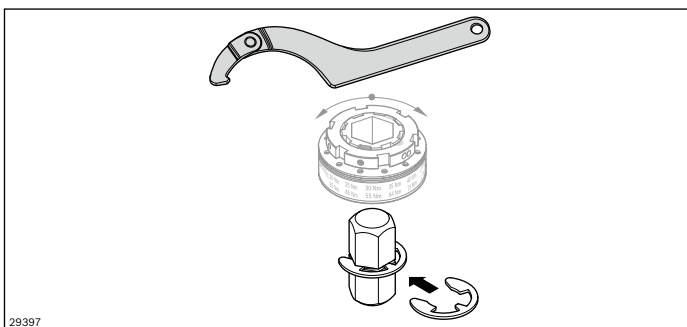

29397

Tool for setting the customer-specific torque of the optionally available safety coupling of the drive kit.

Safety coupling tool	No.
	3 842 549 388

## Bending tool for lateral guide

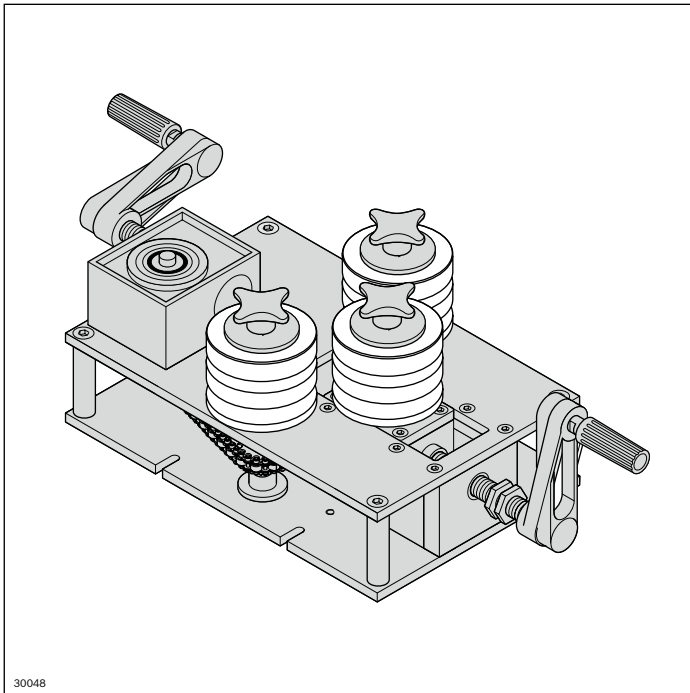

Crank-operated bending tool (A, without set of rollers) for bending profiles. Roller set adjusted to fit the profile rail for lateral guidance of transported material. We do not recommend that you attempt to bend the profile rails yourself. Please contact your Bosch Rexroth distribution partner.

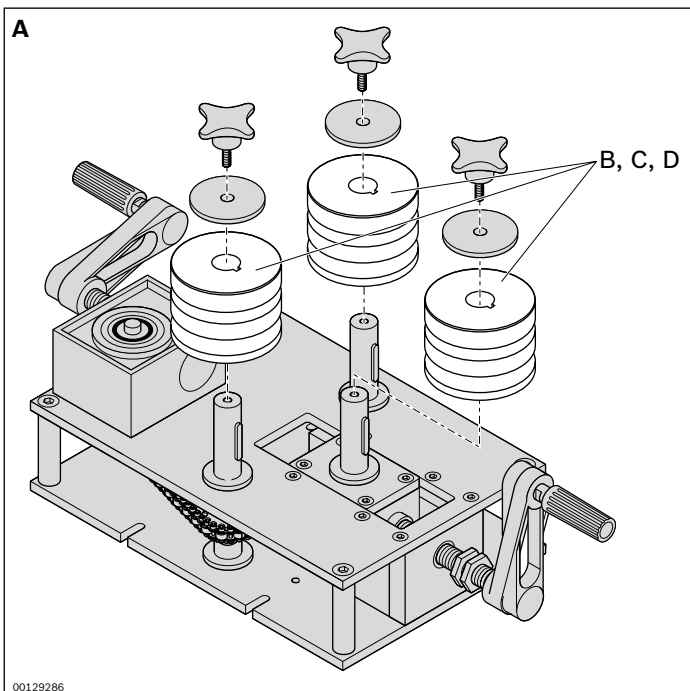

Bending tool for lateral guide		No.	
A		1	3 842 528 531

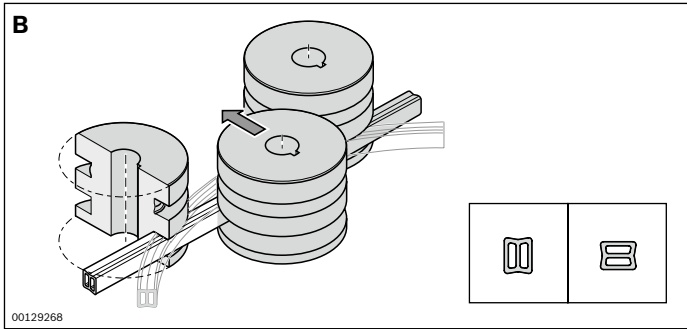

Roller set	No.
<b>B</b>	1 3 842 538 773

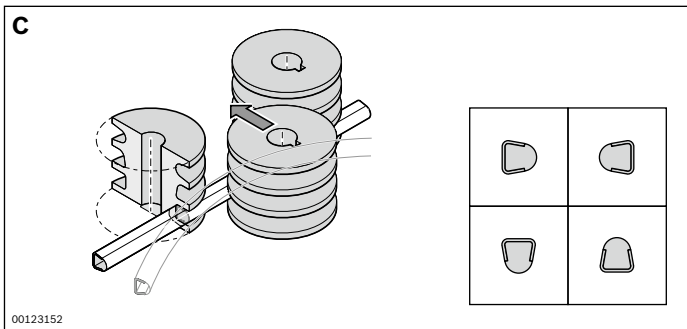

Roller set	No.
<b>C</b>	1 3 842 529 236

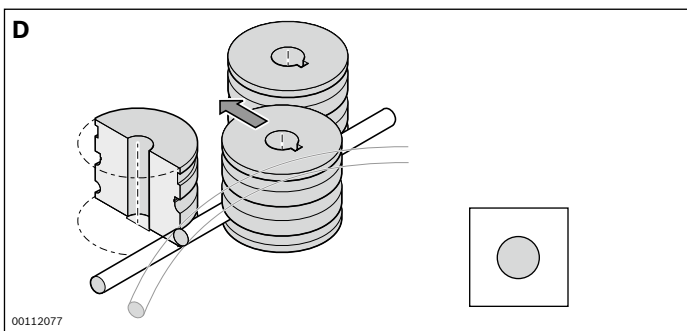

Roller set	No.
<b>D</b>	1 3 842 533 921

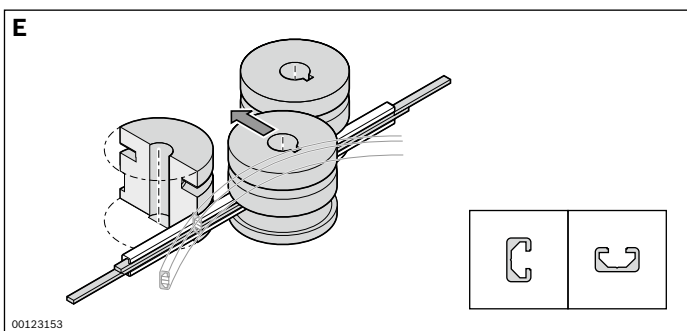

Roller set	No.
<b>E</b>	1 3 842 532 259

# Technical data

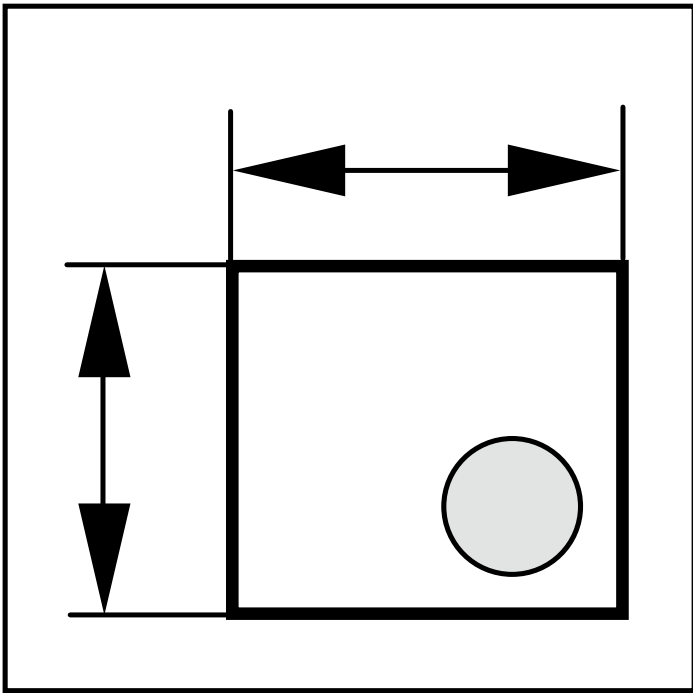

<b>Calculation of chain tensile forces</b>	<b>270</b>
<b>Actual chain and slide rail lengths of components</b>	<b>278</b>
<b>Drive data/Motor data (GM = 1)</b>	<b>279</b>
<b>Motor connection</b>	<b>283</b>
<b>Frequency converter motec 8400 (FU)</b>	<b>284</b>
<b>Ordering parameters for SEW motors (GM = 2)</b>	<b>286</b>
<b>Combination matrix</b>	<b>289</b>
<b>Use in clean rooms</b>	<b>292</b>
<b>Conveyor noise level</b>	<b>294</b>
<b>Resistance of the chain against chemicals</b>	<b>296</b>
<b>Material use</b>	<b>298</b>

## Calculation of chain tensile forces

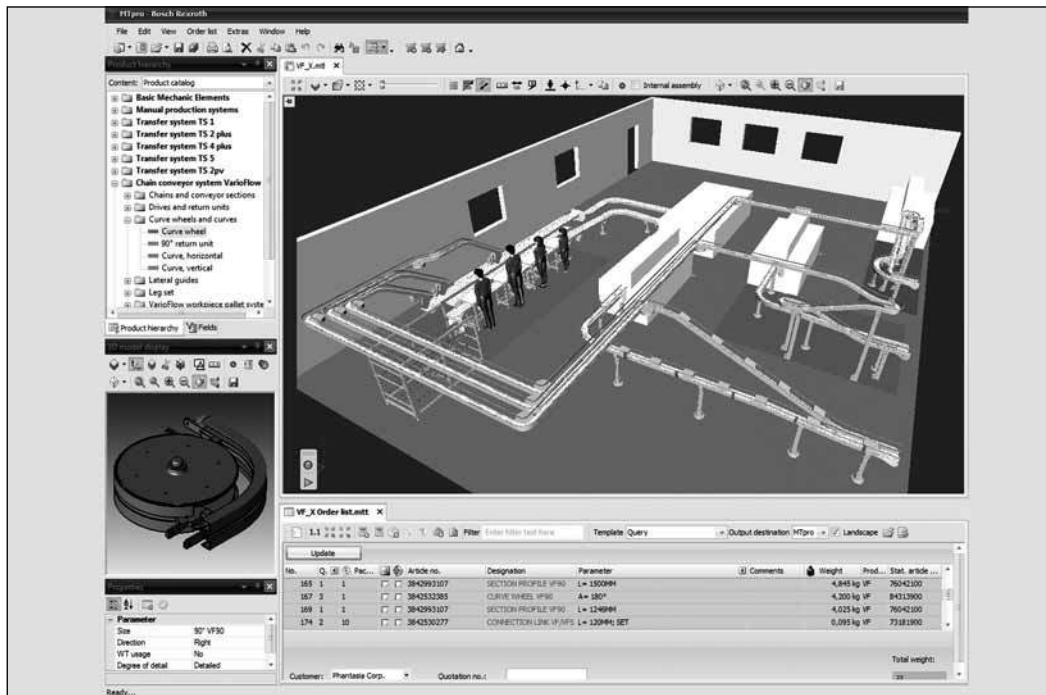

### **MTpro with BKBSOFT – the software for chain calculation**

With the software BKBSOFT you can calculate the maximum chain tensile force and the required drive torque quickly and efficiently.

The tensile force of the conveyor chain is made up of multiple individual forces:

- Sliding friction force between unloaded chain and slide rail
- Sliding friction force between loaded chain and slide rail
- Sliding friction force between accumulated goods and chain

- Tangential components of the goods' and chain's force due to weight in inclining sections
- Sliding friction force in curves, between the chain and the inner slide rail in the curve

The BKBSOFT calculation software, included in the MTpro planning tool, assists you when designing and making the necessary calculations for your VarioFlow chain conveyor system.



$$F_{\text{permissible}} = F_{(a)} \cdot K_T \cdot c_B$$

$$F_{(v)} < F_{(L)} \Rightarrow F_{(a)} = F_{(v)}$$

$$F_{(v)} > F_{(L)} \Rightarrow F_{(a)} = F_{(L)}$$

$F_{(v)}$ , see page 273

$F_{(L)}$ , see page 274

$K_T$ , see page 274

$c_B$ , see page 275

$$M = M_N \cdot \frac{P_V}{P_N}$$

$M_N$ , see page 282

$\frac{P_V}{P_N}$  see page 281

### Calculating the permissible chain tensile force and the permissible drive torque

The permissible chain tensile force depends on the conveying speed as well as the ambient and operating conditions.

If the calculated chain tensile force exceeds the permissible force, you can:

- divide the section into various chain conveyors.
- alter the system layout, e.g. by replacing curves with curve wheels or, if possible, shorten the section.
- shorten the accumulation sections.
- reduce the speed.

### The permissible drive torque of a gear motor is dependent on the transport speed (v), the operating mode (with/without FU), the ambient temperature and the mains frequency.

If the necessary calculated drive torque exceeds that of the selected gear motor, you can:

- reduce the chain tensile force (F).
- reduce the speed (v) and use a gear motor with a higher drive torque, see p. 282.
- change the operating conditions (e. g. the ambient temperature).



### Conveyor chain

The conveyor chain's technical data are included in the chain tensile force calculation as basic data.

Please observe that the breaking force factor depends on the temperature, see p. 274

### Permissible section load of the conveyed goods $q_{Fi}$ :

30 N/chain link (34.5 mm)

	Chain section load (own weight N/m)						
	Flat conveyor chain	Static friction chain	Accumulation roller chain	Universal chain	Cleated chain	Wedge chain 3L	Wedge chain 5L
VFplus 65	9.5	10	16.0	9.5	10.0		
VFplus 90	11.7	12.4	20.5	11.7	12.4	25.3	27.6
VFplus 120	13.5	14.5	25.4	13.5			
VFplus 160	16.7	18.1					
VFplus 240	20.4	22.5					
VFplus 320	22.3	25.2					

10

### Permissible chain tensile force depending on the speed $F_{(v)}$ (N); max. 1250 N

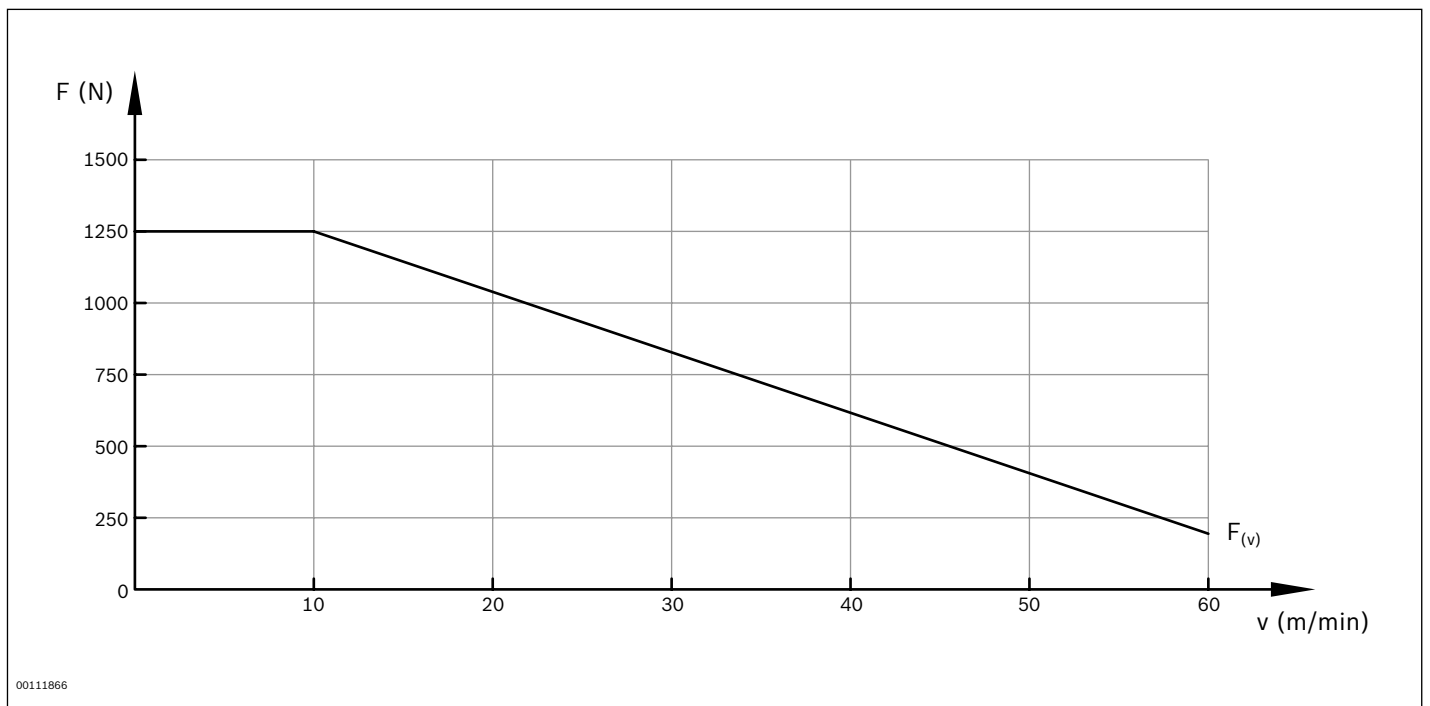

00111866

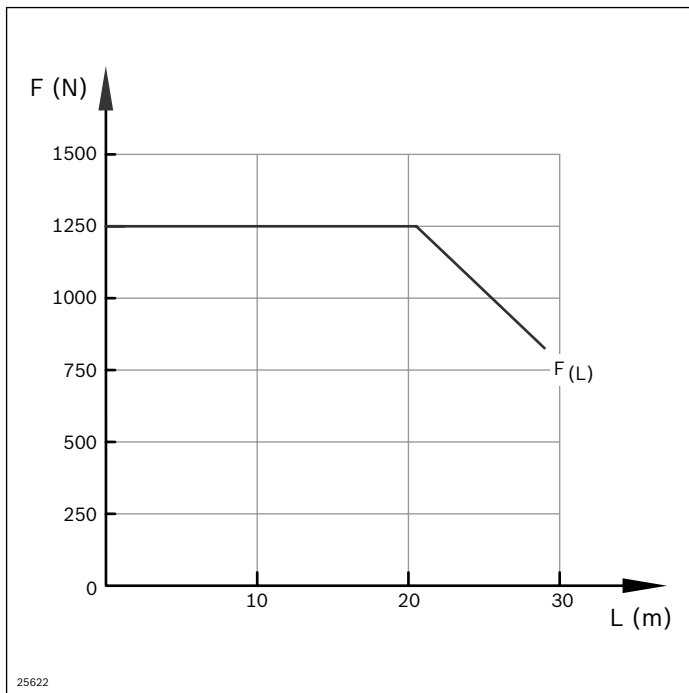

**Permissible chain tensile force depending on the length of the conveyor section;  $F_{(L)}$  (N); max. 1250 N**

**Breaking force and chain elongation depending on the ambient temperature**

The chain material (POM) displays viscoelastic behavior just as every polymer does. This elongates the chain during operation and it is necessary to regularly check the chain elongation and shorten the chain if needed.

A VarioFlow chain conveyor system can be operated without product accumulation and without curves in a temperature range from 0 °C ... + 60 °C. The influence of temperature needs to be taken into account in accumulation operation and for systems with curves.

Other temperatures available on request

Temperature T (°C)	Breaking force factor $K_T$	Chain elongation (%)
0	1.12	-0.2
20	1.00	0
40	0.96	0.2
60	0.94	0.5

**Stick-slip effect**

On conveyor systems with plastic chains, slipping known as the stick-slip effect (chain movement against the direction of transport) may occur in the rear transport area (before the return unit). This is the effect whereby sections of chain take on different running speeds in certain areas, ranging through to a brief standstill.

The effect is more pronounced the larger the distance from the drive. There is no stick-slip effect on the drive unit, as the chain is kept under optimal tension by the chain sprocket.

As a general rule, the stick-slip effect is mostly a visual and not a functional impediment for the continuous material flow. For certain applications, it is important to ensure that sections that may be susceptible to slipping are not used at points in the system with part positioning (e.g. printing).

<b>Curve angles (horizontal/vertical)</b>	<b>Curve factor <math>k_c</math></b>
0° (section without curves)	1.0
Curve wheel 0° ... 180°	1.0
5°	1.05
7.5°	1.05
15°	1.1
30°	1.2
45°	1.3
60°	1.4
90°	1.6

<b>Start-up procedures/h</b>	<b>Operating factor <math>c_B</math></b>
0 ... 1	1.0
2 ... 10	0.83
11 ... 30	0.71
> 30	0.62

### **Curve factor $k_c$**

Additional sliding friction forces occur in curves.

They depend on the curve angle and are included in the required chain tensile force calculation via the curve factor.

### **Operating factor $c_B$**

The permissible chain tensile force depends on the number of start-up procedures per time unit. Clocked operation leads to increased chain stress. The application factor is reduced when using a motor control such as a frequency converter. Intermediate values should be interpolated.

Slide rail	Basic	Advanced	Premium	ESD	steel
<b>Range of application</b>					
$v_{max}$ (m/min)	60	60	100	30	60
Size: 65-120	✓	✓	✓	✓ <sup>1)</sup>	✓ <sup>1),2)</sup>
Size: 160-320	✗	✓	✓	✗	✗
Sliding curves horizontal/vertical	✗	✓	✓	✗	✗
Cleanroom use 	✗	✓	✓	✗	✗

<sup>1)</sup> Only size 65, 90

<sup>2)</sup> Size 120 on request

State of contact surfaces	Basic	Advanced	Premium	ESD	steel
1	0.20	0.15	0.15	0.25	0.26
2	0.25	0.20	0.20	-	0.26
3	> 0.25	> 0.20	> 0.20	-	> 0.26

- 1 Dry, clean =
  - \* No build-up of particles
  - \* Regular cleaning  $\leq 1$  x week
- 2 Remove built-up particles and non-abrasive liquids occasionally, depending on degree of contamination
- 3 If there is constant exposure to particles and liquids, but no abrasive media please contact [www.boschrexroth.com](http://www.boschrexroth.com).

**Note:** We recommend using a homogeneous slide rail variant throughout the entire section, i.e. no mixing of Basic, Advanced, Premium, ESD or steel slide rails within a section.

#### Sliding friction factor between slide rail and chain

Average value, related to the total chain running time.

The sliding friction factor increases along with increasing running time. Lubricant use can reduce this factor.

Material	Condition of the contact surfaces	POM	Steel coated
plastic	Dry	0.25	–
	Water	0.25	–
	Refrigerant	0.12	–
	Oil	0.12	–
Paper	Dry	0.30	
Glass	Dry	0.18	0.25 <sup>3)</sup>
	Water	0.18	
	Refrigerant	0.17	
	Oil	0.17	
Metal	Dry	0.26	0.25 <sup>3)</sup>
	Water	0.26	
	Refrigerant	0.11	
	Oil	0.11	

<sup>3)</sup> With sharp-edged parts, the value must be experimentally determined.







### Sliding friction factor between goods and chain

Sliding friction factors typical for a product type.

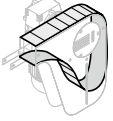
The actual factors must be determined by experimentation for a precise result.

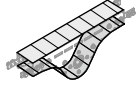
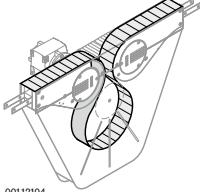
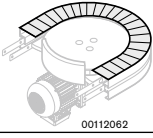
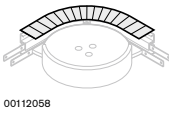
## Actual chain and slide rail lengths of components

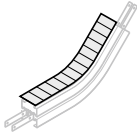
## For an estimated chain and slide rail length calculation

	Actual chain length (m)					Effective slide rail length (m)				
	Size					Size				
	65	90	120	160-320		65	90	120	160-320	
<b>Head drive</b>	1.03					2x 0.2				4x 0.2
<b>Return unit</b>	0.82					2x 0.2				4x 0.2
<b>90° return unit</b>	0.483					4x 117				
<b>Center drive</b>	1.1385					2x 514				
<b>Connection drive</b>	1.51					4x 0.2				
<b>Curve wheel drive</b>	0.68	0.72				0.82	0.91			
<b>Curve wheel</b>	30°	2x 0.28	2x 0.28	2x 0.29		2x 0.34	2x 0.35	2x 0.38		
	45°	2x 0.32	2x 0.33	2x 0.34		2x 0.38	2x 0.41	2x 0.44		
	90°	2x 0.44	2x 0.46	2x 0.48		2x 0.53	2x 0.58	2x 0.63		
	180°	2x 0.68	2x 0.72	2x 0.77		2x 0.82	2x 0.91	2x 1.01		
<b>Roller curve (R500)</b>	30°			2x 0.46					5x 0.46	
	45°			2x 0.59					5x 0.59	
	90°			2x 0.98					5x 0.98	
	180°			2x 1.77					5x 1.77	
<b>Sliding curve horizontal (R700)</b>	30°	2x 0.56				4x 0.56				
	45°	2x 0.75				4x 0.75				
	90°	2x 1.3				4x 1.3				
<b>Vertical curve</b>	5°	2x 0.24				4x 0.24				8x 0.24 <sup>*)</sup>
	7.5°	2x 0.26				4x 0.26				8x 0.26 <sup>*)</sup>
	15°	2x 0.33				4x 0.33				8x 0.33 <sup>*)</sup>
	30°	2x 0.46				4x 0.46				8x 0.46 <sup>*)</sup>
	45°	2x 0.59				4x 0.59				8x 0.59 <sup>*)</sup>
<b>Assembly module</b>	2x 0.24					4x 0.24				6x 0.24

\*) with support profile

## Drive data

### Definition of the basic principles of motor specifications

The specified performances, torques and revolutions per minute are rounded values and apply to:

- Operating time/day = 8 h (100% switched-on time)
- Uniform operation (continual), no, or very light, impacts in a direction of rotation at 10 switching cycles/hour
- Installation positions and designs described in the catalog
- Maintenance-free gears with life-long lubrication,
- Ambient operating temperature 0 ... 60 °C. Gear unit with life-long lubrication for ambient operating temperature ≤0 °C available on request
- Protection class IP 55
- $f_{\text{mains}} = 50$  Hz constant
- $T_U = 20$  °C for gears  
40 °C for motors

- Installation altitude ≤1000 m above sea level
- Overloading the drive will reduce the service life.  
Overloading by 10%: = 75% service life  
Overloading by 20%: = 50% service life
- The gear motor (GM = 1) corresponds to the operating mode S1 (continuous operation)

In the case of other operating conditions, the achievable values may differ from those stated.

In the case of extreme operating conditions, please consult your distribution partner.

10

### Country applicability

	Europe	Switzerland	USA	Canada	Brazil	Australia	New Zealand	South Korea	China	India
Line voltage (3x....)	400 V	400 V	480 V <sup>1)</sup>	480 V <sup>1)</sup> 575 V	220 V 380 V <sup>3)</sup> 440 V <sup>1)</sup>	400 V 415 V <sup>2)</sup>	400 V 415 V <sup>2)</sup>	220 V 380 V <sup>3)</sup> 440 V <sup>1)</sup>	380 V <sup>2)</sup>	415 V <sup>2)</sup>
Line voltage tolerance	±10%	±10%	±10%	±10%	±10%	±5%	±5%			±5%
Line frequency	50 Hz	50 Hz	60 Hz	60 Hz	60 Hz	50 Hz	50 Hz	60 Hz	50 Hz	50 Hz

<sup>1)</sup> ~ 460 V / 60 Hz

<sup>2)</sup> ~ 400 V / 50 Hz

<sup>3)</sup> ~ 400 V / 60 Hz

## Motor data

### Electrical connection requirements:

Connection to a 3-phase, 5-wire system (L1, L2, L3, N, PE), a connection plan is included in the terminal box.

All motors are equipped with a thermal contact<sup>\*)</sup>, which has to be connected to an overload switch-off. All

Of the motors comply with protection type IP 55.

\*) Bi-metal thermal contact, opening, tripping at  $150\text{ °C} \pm 5\text{ °C}$ .

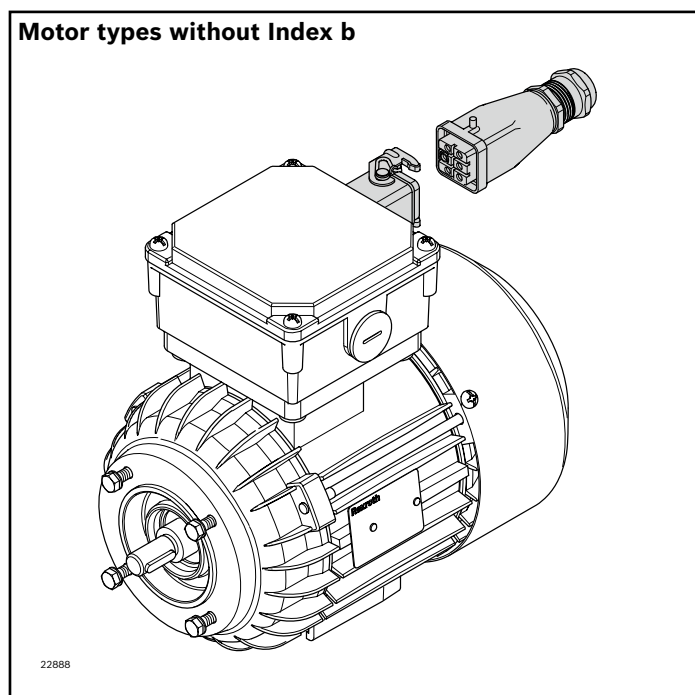

Motor connection with plug (AT = S) and 3A metal industrial plug-in connector for motor types without Index b, e.g. 734

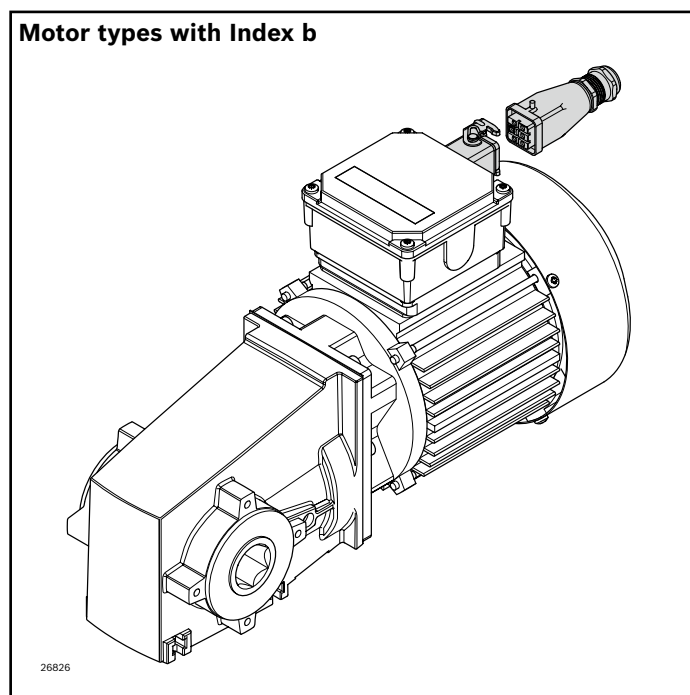

Motor connection with plug (AT = S) and 3A metal industrial plug-in connector for motor types with Index b, e.g. 734b



## Motor data (GM = 1)

### Performance data

**Note:** The data is typical values. We reserve the right to make changes. See motor type plate for official data. Please note the country assignment.

Voltage class	A	A	B	D
Circuit	Δ	Y	Y	Y
Voltage U at f = 50 Hz	200 V ±10%		400 V ±10%	
	200 V ±10%		400 V +10...-12%	
Voltage U at f = 60 Hz	220 V ±10%	400 V ±10%	460 V ±10%	575 V ±10%
	220 V ±10%	400 V ±10%	460 V +10...-12%	575 V ±10%

Motor type	IE3	Current consumption at rated power				Power factor cos φ	Power output for	
		I <sub>N</sub> (A)	I <sub>N</sub> (A)	I <sub>N</sub> (A)	I <sub>N</sub> (A)		(50 Hz) P (kW)	(60 Hz) P (kW)
524	x	0.65	0.35	0.32	0.24	0.6	0.09	0.1
614b	–	–	–	0.49	–	0.56	0.12	0.14
624	x	1.15	0.65	0.55	0.45	0.66	0.18	0.22
634	x	1.65	0.9	0.85	0.65	0.6	0.25	0.29
644b	–	–	–	–	0.75	0.6	0.25	0.29
714b	–	1.75	1	0.8	–	0.64	0.25	0.3
716b	–	1.45	0.85	0.6	0.55	0.66 ... 0.68	0.18	0.22
716	x	1.3	0.75	0.6	0.62	0.68	0.18	0.22
734b	–	2.3	1.35	0.95	0.95	0.72 ... 0.77	0.37	0.45
734	x	1.9	1.05	0.95	0.72	0.74	0.37	0.42
734a	x	2.5	1.4	1.3	1	0.66	0.45	0.52
738b	–	1.4	0.8	0.55	0.5	0.60 ... 0.63	0.12	0.14
744b	–	–	–	1.4	–	0.77	0.55	0.68
814b	–	3	1.75	–	1.27	0.68 ... 0.69	0.55	0.64
814	x	3.1	1.7	1.45	1.1	0.69	0.55	0.63
824	x	4.1	2.25	2	1.6	0.66	0.75	0.86

Suitable for continuous operation, start-stop operation with an operating time of up to 70% and frequency converter operation.

Certification for the motor, cable and plug components:

- IE3 motors: CE, cURUS, CCC
- Motors with Index b: CE/CCC (50 Hz), CE/cURUS (60 Hz)

### 3-phase motors

T <sub>u</sub> (°C)	P <sub>v</sub> / P <sub>N</sub>
< 40	1 <sup>1)</sup>
45	0.95
50	0.90
55	0.85
60	0.8

<sup>1)</sup> Rated motor power (0.37; 0.25; 0.12 kW)

### Rated motor power

The ambient operating temperature T<sub>u</sub> influences the rated power P<sub>N</sub> of the gear motors.

## Motor data (GM = 1)

**Conveyor speed  $v_N$**  is the specification for the rated power and frequency of 50 Hz or 60 Hz.

The actual  $v$  values vary depending on:

- Tolerance of the standard motors
- Performance range of the motors
- Loads on conveyor chain

	Modular unit 50 Hz (see page 281)						Motor type	60 Hz (see page 281)						Motor type
	$v_N$ (m/min)	$v^{1)}$ (m/min)	$i$	$n1^{3)}$ (rpm)	$n2^{4)}$ (rpm)	$M_N$ (Nm)		$v^{1)}$ (m/min)	$i$	$n1^{3)}$ (rpm)	$n2^{4)}$ (rpm)	$M_N$ (Nm)		
<b>Head drive</b>	5	5.3	60	700	11.7	90	738b	6.1	60	804	13.4	82.1	738b	
	10	10.6	60	1400	23.2	90	714b	8.2	60	1080	18.0	90	716b	
	13	13.3	47	1400	29.2	90	734b	12.7	60	1680	28.0	82.1	714b	
	16	16.9	37	1400	37.1	90	734b	16.0	47	1680	35.1	90	734b	
	21	21.7	29	1400	47.7	71.1	734b	20.2	37	1680	44.5	76.1	734b	
	27	27.3	23	1400	60.0	56.5	734b	26.1	29	1680	57.3	59.2	734b	
	33	33.4	19	1400	73.5	46.2	734b	32.8	23	1680	72.0	47.1	734b	
	40	41.0	15	1400	90.0	37.7	734b	40.1	19	1680	88.2	38.4	734b	
	50	50.2	12	1400	110.3	30.8	734b	49.2	15	1680	108.0	31.4	734b	
<b>Connection drive</b>	5	5.3	60	700	11.7	90	738b	6.1	60	804	13.4	82.1	738b	
	10	10.6	60	1400	23.3	90	714b	8.2	60	1080	18.0	90	716b	
	13	13.3	47	1400	29.2	90	734b	12.7	60	1680	28.0	82.1	714b	
	16	16.9	37	1400	37.1	90	734b	16.0	47	1680	35.1	90	734b	
	21	21.7	29	1400	47.7	71.1	734b	20.2	37	1680	44.5	76.1	734b	
	27	27.3	23	1400	60.0	56.5	734b	26.1	29	1680	57.3	59.2	734b	
<b>Curve wheel drive</b>	5	5.0	269	1425	5.3	60 <sup>2)</sup>	614b	5.8	128	800	6.2	60 <sup>2)</sup>	738b <sup>5)</sup>	
		5.8	269	1725	6.0	60 <sup>2)</sup>	614 <sup>6)</sup>	5.8	269	1725	6.0	60 <sup>2)</sup>	614 <sup>6)</sup>	
	10	11.0	60	700	11.7	60 <sup>2)</sup>	738b	12.6	60	804	13.4	60 <sup>2)</sup>	738b	
	13	14.4	60	920	15.3	60 <sup>2)</sup>	716b	17.0	60	1080	18.0	60 <sup>2)</sup>	716b	
	21	21.9	60	1400	23.3	60 <sup>2)</sup>	714b	26.4	60	1680	28.0	60 <sup>2)</sup>	714b	

<sup>1)</sup> Transport speeds at other voltages/frequencies provided on request

<sup>2)</sup> Torque limited to 60 Nm by coupling

<sup>3)</sup> Motor speed

<sup>4)</sup> Gear unit output speed

<sup>5)</sup> Voltage class A + D

<sup>6)</sup> Voltage class B

# Motor connection

## Motor connection with cable/plug (AT = S), circuit diagram

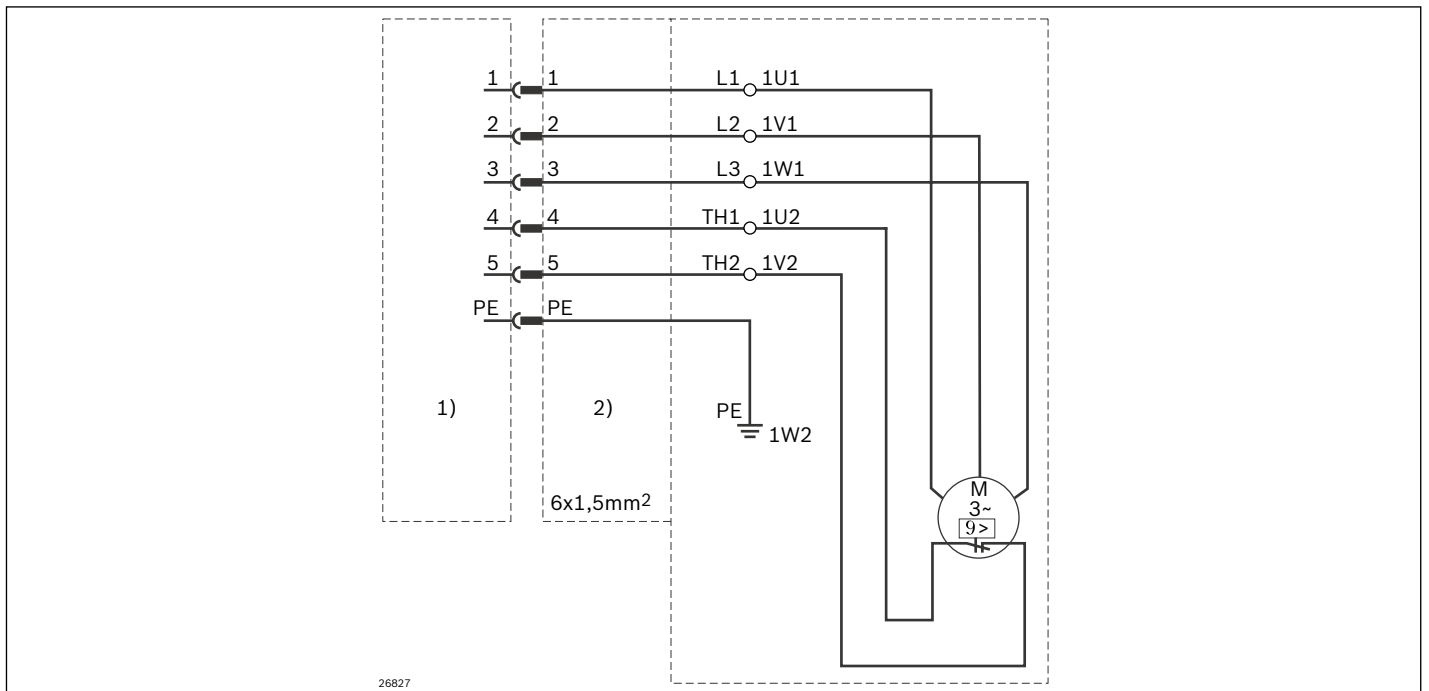

1) Connection cable side

2) Motor side

The plug connection consists of UL components.

### Connection list

Connection terminals, motor 3~	Pin no.	Code
U1	1	L1
V1	2	L2
W1	3	L3
TW1	4	Th1
TW2	5	Th2
	PE	PE

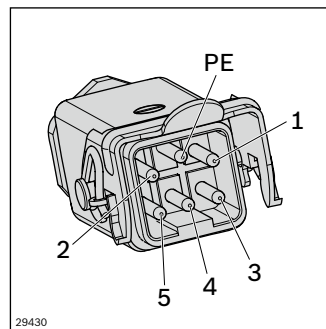

Motor side

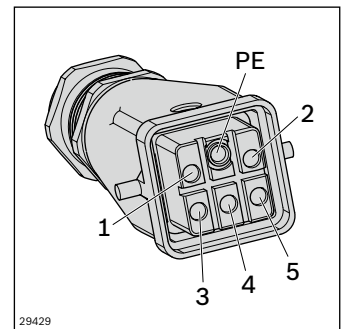

Connection cable side

# Frequency converter motec 8400 (FU)

## Drive range of the motors with frequency converters (FU)

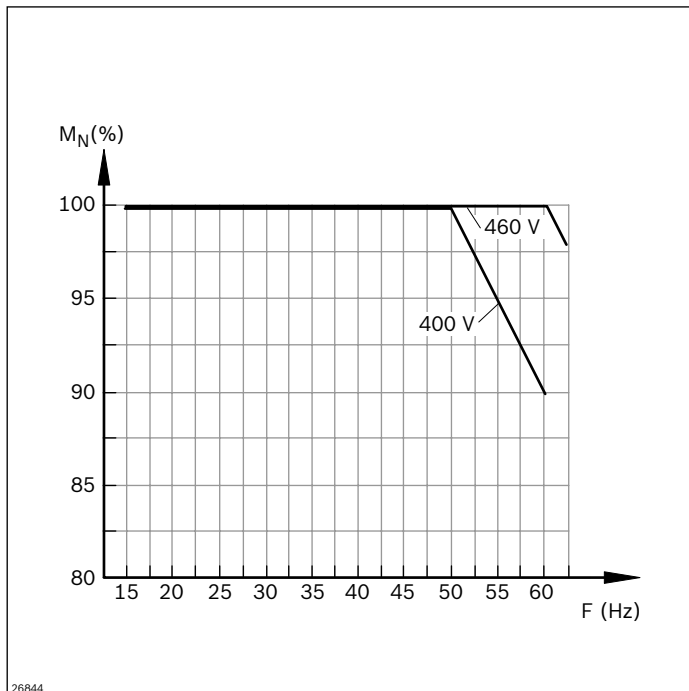

### Technical information:

At rotating field frequencies of  $\geq 15$  Hz, the motor can be operated under normal operating conditions without an external fan. The motor's thermal conditions should be considered at rotating field frequencies of  $\leq 20$  Hz. In the range 20 ... 50 Hz, the full torque is available. At rotating field frequencies  $> 50$  Hz, higher speeds can also be achieved with a corresponding drop in performance.

Base speed of motor (m/min) at 50 Hz	Min <sup>1)</sup> (m/min)	Max <sup>2)</sup> (m/min)	Max (m/min) at max. 80% torque
5 <sup>3)</sup>	2	6	8
10 <sup>3)</sup>	4	12	16
13	5	15	21
16	6	19	26
21	7	25	34
27	9	32	43
33	11	39	52
40	13	48	–
50	16	60	–

<sup>1)</sup> Min corresponds to approx. 16 Hz supply frequency

<sup>2)</sup> Max corresponds to approx. 60 Hz supply frequency

<sup>3)</sup> At 460 V/60 Hz max (m/min) 20% higher

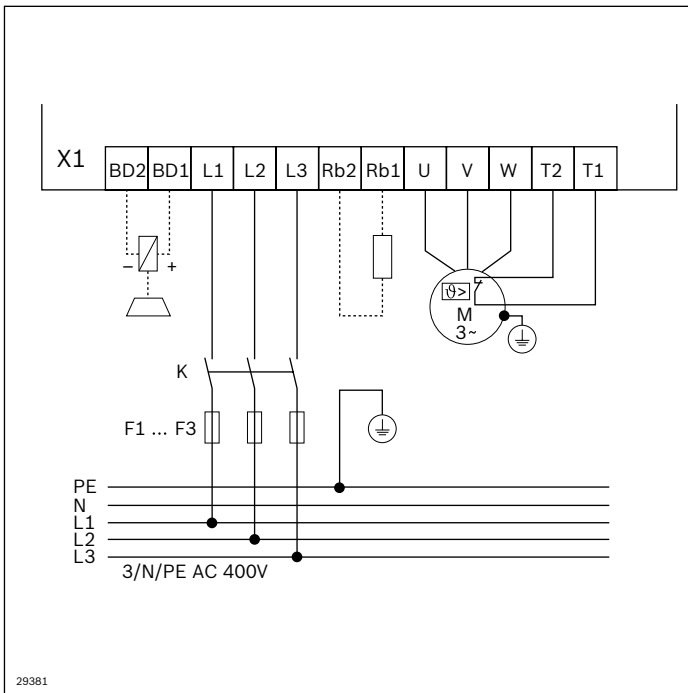

**Frequency converter (FU) accessories**

In order to operate a drive with a frequency converter (FU), the user needs to work out the minimum wiring for the internal and external voltage supply (see terminal assignment plan left).

—— Minimum wiring required for operation  
 ----\*)---- Additional wiring to change direction of rotation

## Ordering parameters for SEW motors (GM = 2)

The following ordering information is required if using gear motors from SEW-Eurodrive GmbH & Co, Bruchsal:

- Motor type
- Ratio
- Installation position
- Position of drive output
- Position of terminal box
- Cable entry (Fig. 4)
- Motor voltage/frequency<sup>1)</sup>
- Thermal class<sup>2)</sup>
- Motor protection class<sup>3)</sup>

<sup>1)</sup> www.seweurodrive.com

### Gear motors for power frequency $f = 50$ Hz

$v_N$ (m/min)	$Is v_N$ (m/min)	Motor type	Ratio	Drive speed gear motor	N (kW)	$M_{max}$ (Nm)
5	4.9	SA47 DR63L4/TH	110.73	12.0	0.25	90
5 <sup>1)</sup>	6.2	SA47 DR63L4/TH	201.00	6.5	0.25	90 / 60 <sup>3)</sup>
5 <sup>2)</sup>	6.7	SA47 DR63L4/TH	201.00	6.5	0.25	90 / 60 <sup>3)</sup>
7	6.2	SA47 DR63L4/TH	84.00	15.0	0.25	90
10	9.9	SA47 DRS71S4/TH	54.59	25.0	0.37	90
10 <sup>1)</sup>	10.5	SA47 DRS71S4/TH	128.10	11.0	0.37	90 / 60 <sup>3)</sup>
10 <sup>2)</sup>	10.4	SA47 DRS71M4/TH	137.05	10.0	0.37	90 / 60 <sup>3)</sup>
13	12.8	SA47 DRS71M4/TH	44.22	31.0	0.37	90
13 <sup>1)</sup>	14.4	SA47 DRS71M4/TH	94.08	15.0	0.37	90 / 60 <sup>3)</sup>
13 <sup>2)</sup>	12.5	SA47 DRS71S4/TH	110.73	12.0	0.37	90 / 60 <sup>3)</sup>
16	14.9	SA47 DRS71S4/TH	38.23	36.0	0.37	78
21	19.9	SA47 DRS71S4/TH	29.00	48.0	0.37	60
21 <sup>1)</sup>	21.1	SA47 DRS71S4/TH	63.80	31.0	0.37	60
21 <sup>2)</sup>	20.7	SA47 DRS71S4/TH	69.39	20.0	0.37	60
27	24.4	SA47 DRS71S4/TH	23.20	59.0	0.37	49
33	32.3	SA47 DRS71S4/TH	17.62	78.0	0.37	40
40	39.7	SA47 DRS71M4/TH	14.24	97.0	0.55	48
50	46.4	SA47 DRS71M4/TH	12.10	114.0	0.55	41
4 ... 26	2.22 ... 22.0	SA47 DRS71S4 MM05	54.59	5.3 ... 53.0	0.55	69 ... 81
16 ... 60	6.7 ... 68.3	SA47 DRS71M4 MM07	17.62	16 ... 165.0	0.75	36 ... 39

For basic unit curve wheel drive:

<sup>1)</sup> VFplus 65 (z = 28 / ø306 mm)

<sup>2)</sup> VFplus 90 (z = 30 / ø331 mm)

<sup>3)</sup> at KPG = 1 limited to 60 Nm

**Gear motors for power frequency f = 60 Hz**

$v_N$ (m/min)	$Is v_N$ (m/min)	Motor type	Ratio	Drive speed gear motor	N (kW)	$M_{max}$ (Nm)
5	4.9	SA47 DR63L4/TH	128.10	12.0	0.25	90
5 <sup>1)</sup>	7.4	SA47 DR63L4/TH	201.00	7.8	0.25	90 / 60 <sup>3)</sup>
5 <sup>2)</sup>	8.1	SA47 DR63L4/TH	201.00	7.8	0.25	90 / 60 <sup>3)</sup>
7	7.0	SA47 DR63L4/TH	94.08	16.8	0.25	90
10	9.9	SA47 DRS71S4/TH	63.80	24.0	0.25	90
10 <sup>1)</sup>	9.4	SA47 DRS71S4/TH	158.12	9.8	0.25	90 / 60 <sup>3)</sup>
10 <sup>2)</sup>	10.2	SA47 DRS71M4/TH	158.12	9.8	0.25	90 / 60 <sup>3)</sup>
13	12.4	SA47 DRS71M4/TH	54.59	30.0	0.37	90
13 <sup>1)</sup>	13.8	SA47 DRS71M4/TH	110.73	14.4	0.37	90 / 60 <sup>3)</sup>
13 <sup>2)</sup>	13.7	SA47 DRS71S4/TH	128.10	13.2	0.37	90 / 60 <sup>3)</sup>
16	15.4	SA47 DRS71S4/TH	44.22	37.2	0.37	90
21	20.9	SA47 DRS71S4/TH	32.48	50.4	0.37	67
21 <sup>1)</sup>	21.9	SA47 DRS71S4/TH	71.75	22.8	0.37	67 / 60 <sup>3)</sup>
21 <sup>2)</sup>	23.7	SA47 DRS71S4/TH	71.75	22.8	0.37	67 / 60 <sup>3)</sup>
27	27.8	SA47 DRS71S4/TH	24.77	67.2	0.37	52
33	33.8	SA47 DRS71S4/TH	20.33	81.6	0.37	46
40	41.7	SA47 DRS71M4/TH	16.47	100.8	0.37	37
50	47.7	SA47 DRS71M4/TH	14.24	116.4	0.55	48
4 ... 26	2.22 ... 22.0	SA47 DRS71S4 MM05	54.59	5.3 ... 53.0	0.55	69 ... 81
16 ... 60	6.7 ... 68.3	SA47 DRS71M4 MM07	17.62	16 ... 165.0	0.75	36 ... 39

For basic unit curve wheel drive:

<sup>1)</sup> VFplus 65 (z = 28 / ø306 mm)

<sup>2)</sup> VFplus 90 (z = 30 / ø331 mm)

<sup>3)</sup> at KPG = 1 limited to 60 Nm

**Direct head drive**

Motor mounting	Installation position	Drive output	Terminal box
R	M2 (M1)	B	0°
L	M2 (M1)	A	180°

**Position of terminal box**

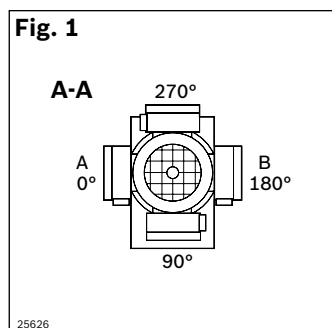

**Installation position horizontal top/vertical**

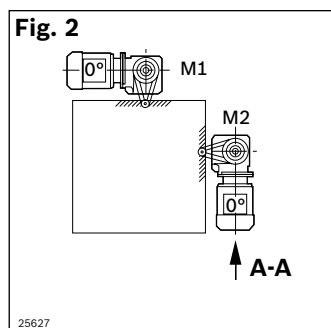

**Installation position horizontal (above top edge chain)**

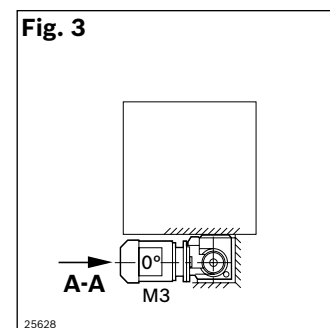

**Cable entry point**

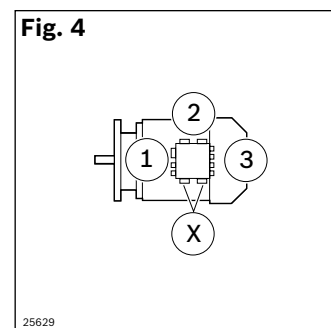



# Combination matrix



		Straight			Curves				Drives			Return unit		Transmission kit	
		Section profile AL open	Section profile AL closed	Assembly module	Curve wheel	Roller curve*	Horizontal sliding curve	Vertical curve	Head drive	Curve wheel drive	Connection drive	Center drive (STS)	Basic unit		90° **(STS)
<b>Straight</b>	Section profile AL open	J													
	Section profile AL closed	J	J												
	Assembly module	J	J	N											
<b>Curves</b>	Curve wheel	J	J	L <sup>2)</sup>	L <sup>2)</sup>										
	Roller curve*	J	N	J	N	L <sup>1)</sup>									
	Horizontal sliding curve	J	J	J	J	N	L <sup>1)</sup>								
	Vertical curve	J	J	J	J	L <sup>1)</sup>	L <sup>1)</sup>	L <sup>1)</sup>							
<b>Drives</b>	Head drive	J	J	L <sup>2)</sup>	L <sup>2)</sup>	L <sup>1,4)</sup>	L <sup>1)</sup>	L <sup>1,4)</sup>	N						
	Curve wheel drive	J	J	L <sup>2)</sup>	L <sup>2)</sup>	N	L <sup>1)</sup>	L <sup>1)</sup>	N	N					
	Connection drive	J	J	L <sup>2)</sup>	L <sup>2)</sup>	N	L <sup>1)</sup>	L <sup>1)</sup>	N	N	N				
	Center drive (STS)**	L <sup>5)</sup>	L <sup>5)</sup>	L <sup>2,5)</sup>	L <sup>2,5)</sup>	N	L <sup>1,5)</sup>	L <sup>1,5)</sup>	N	N	N	N			
<b>Return unit</b>	Basic unit	J	J	L <sup>2)</sup>	L <sup>2)</sup>	L <sup>1,4)</sup>	L <sup>1)</sup>	L <sup>1,4)</sup>	L <sup>2)</sup>	N	N	L <sup>2,3)</sup>	L <sup>2,3)</sup>		
	90° (STS)**	L <sup>5)</sup>	L <sup>5)</sup>	L <sup>2,5)</sup>	L <sup>2,5)</sup>	N	L <sup>1,5)</sup>	L <sup>1,5)</sup>	N	N	L <sup>2,5)</sup>	N	N	L <sup>2)</sup>	
<b>Transmission kit</b>		N	N	N	N	N	N	N	J	N	J	N	J	N	N

10

J possible without restrictions

L possible with restrictions

N not possible

\* Support profile must project 76+2 mm into the roller curve.

\*\* AL-STS adapter included in scope of delivery.

<sup>1)</sup> Profile connector not required

<sup>2)</sup> Use of a profile piece ( $L_{\min} = 120$  mm)

<sup>3)</sup> Assembly module required

<sup>4)</sup> For sizes 160-320: shorten the support rail on the dotted line (see figure below)

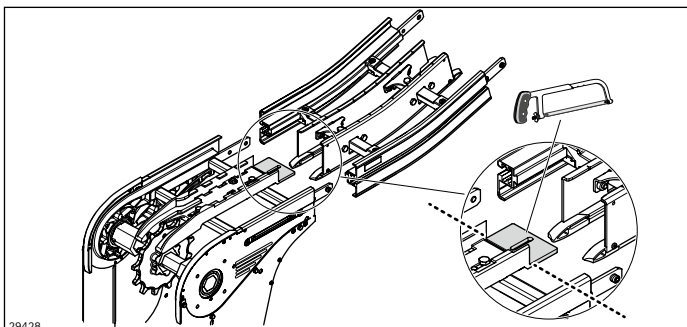
<sup>5)</sup> Use of the AL-STS adapter



		Straight			Curves			Drives			Return unit	
		Section profile STS open	Section Profile STS Clean	Assembly module	Curve wheel	Roller curve*	Vertical curve	Head drive	Connection drive	Center drive	Basic unit	90° **
<b>Straight</b>	Section profile STS open	J										
	Section Profile STS Clean	L <sup>6)</sup>	L <sup>6)</sup>									
	Assembly module	J	L <sup>6)</sup>	N								
<b>Curves</b>	Curve wheel	J	L <sup>6)</sup>	J	L <sup>2, 7)</sup>							
	Roller curve*	J	N	J	N	L <sup>1)</sup>						
	Vertical curve	J	L <sup>6)</sup>	J	L <sup>1)</sup>	L <sup>1)</sup>	L <sup>1)</sup>					
<b>Drives</b>	Head drive	J	L <sup>6)</sup>	J	L <sup>1)</sup>	L <sup>1, 4)</sup>	L <sup>1, 4)</sup>	N				
	Connection drive	J	L <sup>6)</sup>	J	L <sup>1)</sup>	N	L <sup>1)</sup>	N	N			
	Center drive**	J	L <sup>6)</sup>	J	L <sup>1)</sup>	N	L <sup>1)</sup>	N	N	N		
<b>Return unit</b>	Basic unit	J	L <sup>6)</sup>	J	L <sup>1)</sup>	L <sup>1, 4)</sup>	L <sup>1, 4)</sup>	L <sup>1)</sup>	L <sup>1)</sup>	L <sup>1, 3)</sup>	L <sup>1, 3)</sup>	
	90° **	J	L <sup>6)</sup>	J	L <sup>1)</sup>	N	L <sup>1)</sup>	L <sup>1)</sup>	L <sup>1)</sup>	N	N	L <sup>1)</sup>

J	possible without restrictions
L	possible with restrictions
N	not possible

\* Support profile must project 76+2 mm into the roller curve.  
 \*\* AL-ST5 adapter included in scope of delivery.

- <sup>1)</sup> Profile connector not required
- <sup>2)</sup> Use of a profile piece (L<sub>min</sub> = 224 mm)
- <sup>3)</sup> Assembly module required
- <sup>4)</sup> For sizes 160-320: shorten the support rail on the dotted line (see figure below)
- <sup>5)</sup> Use of the AL-ST5 adapter
- <sup>6)</sup> Replacement of the standard profile connector with profile connector STS Clean Section
- <sup>7)</sup> Directly possible with left-right change (one profile connector no longer required)

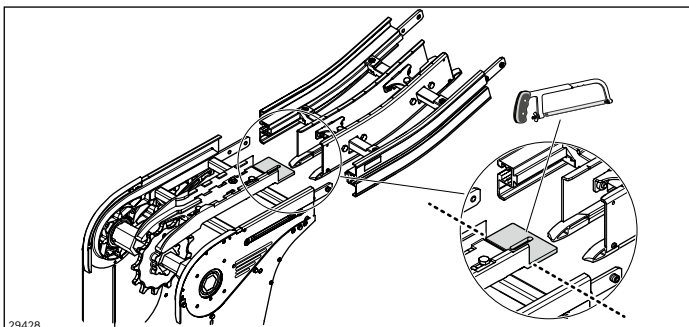



		Straight			Curves		Drives			Return unit	
		Section profile AL open	Section profile AL closed	Assembly module	Curve wheel ESD	Vertical curve (STS)	Head drive (STS)	Connection drive (STS)	Center drive (STS)	Basic unit (STS)	90° ** (STS)
<b>Straight</b>	Section profile AL open	J									
	Section profile AL closed	J	J								
	Assembly module	J	J	N							
<b>Curves</b>	Curve wheel ESD	J	J	L <sup>2)</sup>	L <sup>2)</sup>						
	Vertical curve	J	J	L <sup>2)</sup>	L <sup>2)</sup>	L <sup>1)</sup>					
<b>Drives</b>	Head drive (STS)	L <sup>5)</sup>	L <sup>5)</sup>	L <sup>2, 5)</sup>	L <sup>2, 5)</sup>	L <sup>1, 5)</sup>	N				
	Connection drive (STS)	L <sup>5)</sup>	L <sup>5)</sup>	L <sup>2, 5)</sup>	L <sup>2, 5)</sup>	L <sup>1, 5)</sup>	N	N			
	Center drive (STS)**	L <sup>5)</sup>	L <sup>5)</sup>	L <sup>2, 5)</sup>	L <sup>2, 5)</sup>	L <sup>1, 5)</sup>	N	N	N		
<b>Return unit</b>	Basic unit (STS)	L <sup>5)</sup>	L <sup>5)</sup>	L <sup>2, 5)</sup>	L <sup>2, 5)</sup>	L <sup>1, 5)</sup>	L <sup>2)</sup>	N	L <sup>2)</sup>	L <sup>2, 3)</sup>	
	90° (STS)**	L <sup>5)</sup>	L <sup>5)</sup>	L <sup>2, 5)</sup>	L <sup>2, 5)</sup>	L <sup>1, 5)</sup>	L <sup>2)</sup>	L <sup>2)</sup>	N	N	L <sup>2)</sup>

J possible without restrictions

L possible with restrictions

N not possible

\* Support profile must project 76+2 mm into the roller curve.

\*\* AL-ST5 adapter included in scope of delivery.

<sup>1)</sup> Profile connector not required

<sup>2)</sup> Use of a profile piece ( $L_{\min} = 224$  mm)

<sup>3)</sup> Assembly module required

<sup>4)</sup> For sizes 160-320: shorten the support rail on the dotted line

<sup>5)</sup> Use of the AL-ST5 adapter

<sup>6)</sup> Replacement of the standard profile connector with profile connector ST5 Clean Section

<sup>7)</sup> Directly possible with left-right change (one profile connector no longer required)

## Use in clean rooms

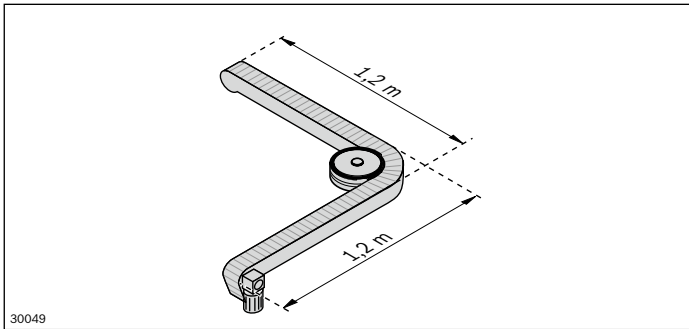

The VarioFlow *plus* 90 conveyor system has been tested for cleanroom suitability according to the procedures described in the EN ISO 14644-1 standard for cleanroom and cleanliness suitability testing. The measurement results for a conveyor system VarioFlow *plus* 90 (AL) were obtained and are presented in the table at left.

The results are based on an application in an L-configuration using a curve wheel 90° and flat conveyor chain, without load!

**Values for Premium and Advanced slide rails**

Speed $v$ (m/min)	ISO class
6	6
20	7
50	7

Before commissioning a chain conveyor system in a cleanroom, the following must be observed:

- Install the slide rails according to the assembly instructions (avoid joints, round off all edges and intersections on the slide rails)
- Check the chain inlets and outlets, if necessary round off edges
- Check the intersections, if necessary round off edges
- Run in for about 100 hours to adapt the slide rail and chain (abrasion and unevenness of plastics)
- Clean the system and the chain
- Transfer of the system via airlock into the cleanroom
- Repeatedly clean the system and the chain with isopropanol

Due to the identical system configurations of sizes 65 and 120, the result can also be transferred to these sizes. Sliding curves are not suitable for use in cleanrooms due to the increased friction and associated wear.



# Conveyor noise level

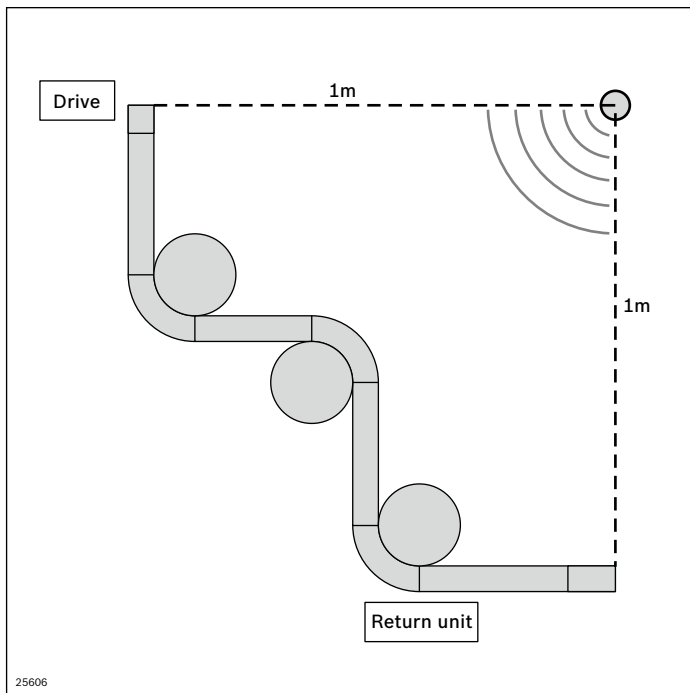

The noise generated by the conveyor chain will decrease after a few days of operation. Generally, a higher speed will result in a higher noise level. The actual noise level depends on several factors:

- Product on the conveyor
- Chain type
- Drive type
- Installation location and fastening of the system (floor, ceiling, wall)
- Ambient conditions (vibrating objects, hard reflective walls, integrated systems of other makes, hall structures)
- Quality of system assembly and layout in accordance with the assembly instructions (slide rail transitions, joints)
- Surrounding equipment
- Conveyor layout and dimensions

Typical noise levels are shown in the graphic. The noise level was measured at the transport height with a distance of 1 m from the conveyor.

The measurement was taken in an industrial hall (ambient noise from approx. 50 dB (A) to 63 dB (A)) for chain speeds up to 60 m/min and with medium-length chain bag.

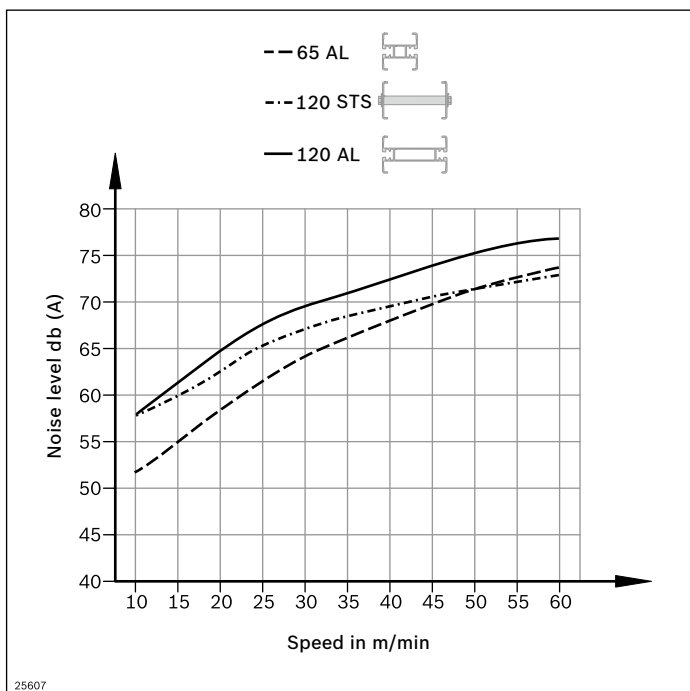

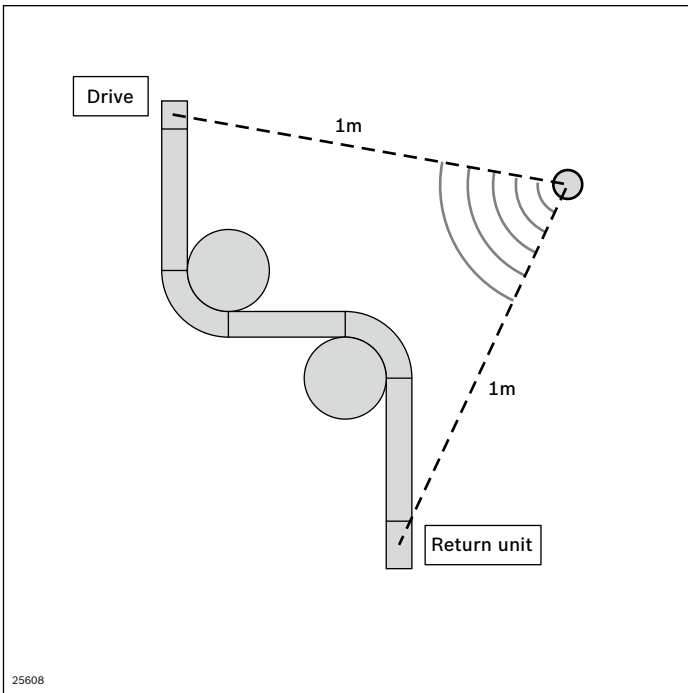

25608

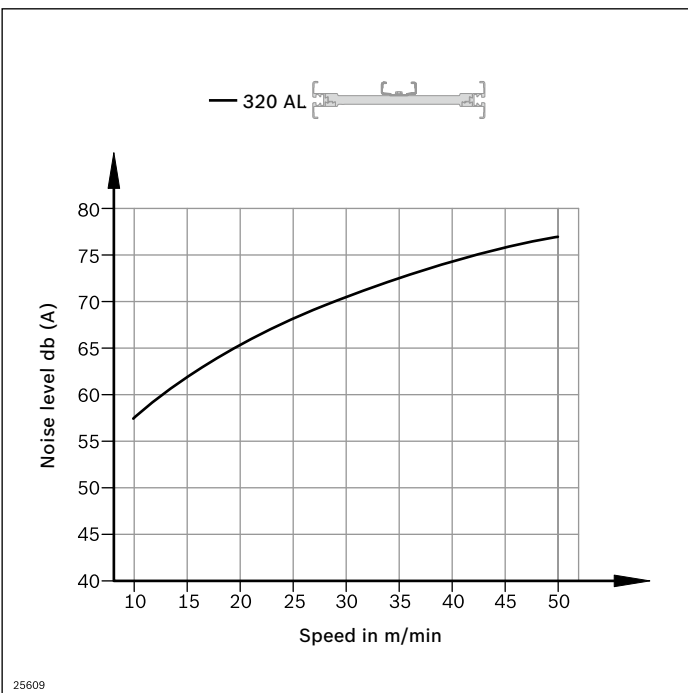

25609

## Resistance of the chain against chemicals

Chemical	Material
Acids:	POM
Benzoic acid	0
Hydrogen cyanide	-
Boric acid	0
Chromic acid	-
Acetic acid	0
Hydrofluoric acid	-
Tannic acid	0
Oleic acid	0
Oxalic acid	-
Perchloric acid	-
Phosphoric acid	-
Phthalic acid	-
Nitric acid	-
Hydrochloric acid	-
Sulfuric acid	-
Tartaric acid	0
Citric acid	0

++ = high resistance

+ = limited resistance

0, - = unsuitable material combination

·/· = no available data

The materials used are resistant to most chemicals used in industrial applications.

With some chemicals, the reaction also depends on the concentration and the physical state.

Contact with the following substances should be avoided:

- Acids with a pH level  $\leq 4$
- Bases with a pH value  $\geq 9$
- Chlorinated hydrocarbons (e.g. trichloroethylene/Tri).

For accurate information on resistance, contact the chemical manufacturer; only they can give an official answer to your question. The materials used in the individual components can be found on pages 298 and 217.



Chemical	Material
<b>Alkaline substances:</b>	<b>POM</b>
Ammonia (dissolved)	++
Lime hydrate	++
Sodium hydroxide	++
Caustic potash	++
<b>Salts:</b>	
Basic salts	++
Potassium bicarbonate	+
Potassium permanganate	+
Sodium cyanide	+
Sodium hypochloride	0
Neutral salts	++
Acidic salts	+
<b>Solvents/organic media:</b>	
Acetone	+
<b>Solvents/organic media:</b>	
Aniline	+
Gasoline	+
Benzene	++
Butanol	+
Chlorobenzene	++
Chloroform	++
Acetic ether	++
Ethyl alcohol	++
Ethyl ether	++
Formalin	+
Heptane	+
Methyl alcohol	++
Methyl ethyl ketone	++
Nitrobenzene	+

Chemical	Material
<b>Solvents/organic media:</b>	
Phenol	0
Carbon disulfide	++
Turpentine substitute	·/·
Carbon tetrachloride	++
Toluene	++
<b>Gases:</b>	
Chlorine (wet)	-
Chlorine (dry)	+
Carbon dioxide	0
Carbon monoxide	+
Sulfur dioxide (wet)	-
Sulfur dioxide (dry)	+
Hydrogen sulfide	0

# Material use

## Chains

	Steel, stainless	POM	PA	TPE
Flat conveyor chain	x	x	x	
Static friction chain	x	x	x	x
Accumulation roller chain	x	x	x	
Roller cleat chain ø20	x	x	x	
Roller cleat chain ø35	x	x	x	
Cleated chain	x	x	x	
Universal chain	x	x	x	
Steel-coated chain	x	x	x	
Flocked chain	x	x	x	
Wedge chain	x	x	x	x
ESD conveyor chain	x	x	x	

## Drives

	Aluminum	Aluminum, die-cast	Galvanized steel	Steel, stainless	steel	PA	PP
Head/connection drive AL	x	x	x	x		x	x
Head/connection/curve wheel drive AL incl. ball catch coupling	x	x	x	x	x	x	x
Head/connection/center drive STS				x		x	x
Return unit AL	x	x	x	x		x	x
STS return unit				x		x	x
90° return unit				x		x	x
Passive bridge connection kit				x		x	

**Sections**

	Anodized aluminum	Aluminum, die-cast	Steel, galvanized	Steel, stainless	Brass, nickel-plated	PA	PP	PE-UHMW	PE	HDPE
Straight section AL	x	x	x							
Straight section STS				x						
Vertical + horizontal sliding curve AL	x		x							
Vertical sliding curve STS				x						
Curve wheel AL	x	x	x	x		x				
Curve wheel STS				x		x				
Roller curve AL	x	x	x	x		x		x		
Roller curve STS				x		x		x		
Chain assembly module AL	x		x							
Chain assembly module STS				x						
Leg sets AL	x	x	x				x			
Leg sets STS			x	x	x	x				
Lateral guide	x		x	x		x			x	x
Plastic slide rail								x		
STS slide rail				x						

## Material number overview

3 842 146 901	62	3 842 538 773	267	3 842 546 089	177	3 842 547 062	71
3 842 168 600	239	3 842 538 829	202	3 842 546 090	43	3 842 547 063	71
3 842 191 182	62	3 842 538 955	62	3 842 546 091	43	3 842 547 064	71
3 842 345 081	63	3 842 538 957	62	3 842 546 093	20	3 842 547 065	71
3 842 509 185	111, 113	3 842 539 339	212	3 842 546 094	20	3 842 547 066	71
3 842 511 874	111, 113	3 842 539 340	203	3 842 546 095	21	3 842 547 067	71
3 842 513 581	227	3 842 539 344	212	3 842 546 096	24	3 842 547 068	71
3 842 513 584	227	3 842 539 345	204	3 842 546 097	24	3 842 547 069	71
3 842 518 367	62	3 842 539 494	210	3 842 546 098	25	3 842 547 070	71
3 842 518 368	62	3 842 539 495	210	3 842 546 107	33	3 842 547 071	71
3 842 518 369	62	3 842 539 496	211	3 842 546 116	57, 61, 129, 133	3 842 547 072	73
3 842 523 258	62	3 842 539 497	211			3 842 547 073	73
3 842 527 553	187, 189	3 842 539 498	209	3 842 546 120	81	3 842 547 074	73
3 842 527 738	206	3 842 539 499	209	3 842 546 121	81	3 842 547 075	73
3 842 527 851	206	3 842 539 500	211	3 842 546 122	81	3 842 547 076	73
3 842 528 009	210	3 842 539 501	212	3 842 546 123	81	3 842 547 077	73
3 842 528 531	266	3 842 539 505	212	3 842 546 124	81	3 842 547 078	73
3 842 528 539	213	3 842 539 613	204	3 842 546 125	81	3 842 547 079	73
3 842 528 540	213	3 842 539 826	212	3 842 546 625	111	3 842 547 080	73
3 842 528 715	63	3 842 540 173	115	3 842 546 626	111	3 842 547 081	73
3 842 528 718	63	3 842 540 668	112	3 842 546 627	111	3 842 547 082	73
3 842 528 721	63	3 842 541 003	260	3 842 546 628	115	3 842 547 083	75
3 842 528 724	63	3 842 541 246	64	3 842 546 629	115	3 842 547 084	75
3 842 528 727	63	3 842 541 409	64	3 842 546 630	115	3 842 547 085	75
3 842 528 772	223	3 842 541 566	223	3 842 546 632	117	3 842 547 086	75
3 842 528 773	223	3 842 541 567	223	3 842 546 643	53	3 842 547 087	75
3 842 528 817	236	3 842 541 888	223	3 842 546 644	53	3 842 547 088	75
3 842 528 852	232	3 842 541 889	223	3 842 546 645	53	3 842 547 089	75
3 842 529 039	115	3 842 541 902	225	3 842 546 647	2, 55	3 842 547 090	75
3 842 529 236	267	3 842 541 903	225	3 842 546 649	125	3 842 547 091	75
3 842 529 347	115	3 842 543 246	223	3 842 546 658	169, 187	3 842 547 092	75
3 842 529 386	113	3 842 544 875	111, 113	3 842 546 659	169, 187	3 842 547 093	75
3 842 529 850	203	3 842 546 000	19	3 842 546 660	169	3 842 547 094	75
3 842 530 236	168	3 842 546 001	19	3 842 546 661	169	3 842 547 095	75
3 842 530 277	60	3 842 546 002	19	3 842 546 662	169	3 842 547 096	75
3 842 530 281	64	3 842 546 006	23	3 842 546 663	169	3 842 547 097	75
3 842 530 283	64	3 842 546 007	23	3 842 546 670	55	3 842 547 098	75
3 842 530 285	64, 210, 211	3 842 546 008	23	3 842 546 672	2, 55	3 842 547 099	75
		3 842 546 012	39	3 842 546 673	55	3 842 547 100	75
3 842 530 287	64, 187	3 842 546 013	39	3 842 546 674	55	3 842 547 101	75
3 842 531 355	238	3 842 546 014	40	3 842 546 675	55	3 842 547 102	75
3 842 531 552	227	3 842 546 015	37	3 842 546 676	55	3 842 547 103	75
3 842 532 151	259	3 842 546 016	37	3 842 546 677	55	3 842 547 104	75
3 842 532 259	267	3 842 546 017	27	3 842 546 684	125	3 842 547 105	75
3 842 532 762	241	3 842 546 018	27	3 842 546 685	125	3 842 547 106	75
3 842 532 980	228	3 842 546 019	28	3 842 546 686	125	3 842 547 107	75
3 842 532 998	228	3 842 546 020	31	3 842 546 687	125	3 842 547 108	75
3 842 533 306	169	3 842 546 021	31	3 842 546 688	125	3 842 547 109	75
3 842 533 307	169	3 842 546 028	20, 21, 24, 25	3 842 546 689	125	3 842 547 110	75
3 842 533 308	169			3 842 546 700	125	3 842 547 111	137
3 842 533 309	169	3 842 546 069	19	3 842 546 705	55	3 842 547 112	137
3 842 533 310	169	3 842 546 070	19	3 842 546 706	125, 210, 211	3 842 547 113	137
3 842 533 841	195, 203	3 842 546 071	19			3 842 547 114	137
3 842 533 901	169	3 842 546 072	20	3 842 546 707	125	3 842 547 115	137
3 842 533 915	129	3 842 546 073	20	3 842 546 717	112	3 842 547 116	137
3 842 533 921	267	3 842 546 074	21	3 842 546 718	112	3 842 547 117	137
3 842 535 001	245	3 842 546 075	19	3 842 547 048	69	3 842 547 118	137
3 842 535 002	245	3 842 546 076	19	3 842 547 049	69	3 842 547 119	137
3 842 535 003	245	3 842 546 077	23	3 842 547 050	69	3 842 547 120	137
3 842 535 004	245	3 842 546 078	23	3 842 547 051	69	3 842 547 121	137
3 842 535 081	225	3 842 546 079	23	3 842 547 052	69	3 842 547 122	137
3 842 535 150	247	3 842 546 080	24	3 842 547 053	69	3 842 547 123	139
3 842 535 801	241	3 842 546 081	24	3 842 547 054	69	3 842 547 124	139
3 842 536 295	206	3 842 546 082	25	3 842 547 055	69	3 842 547 125	139
3 842 536 787	227	3 842 546 083	27	3 842 547 056	69	3 842 547 126	139
3 842 538 208	204	3 842 546 084	27	3 842 547 057	69	3 842 547 127	139
3 842 538 209	203	3 842 546 085	28	3 842 547 058	69	3 842 547 128	139
3 842 538 388	203	3 842 546 086	47	3 842 547 059	69	3 842 547 129	139
3 842 538 389	204	3 842 546 087	47	3 842 547 060	71	3 842 547 130	139
3 842 538 717	113	3 842 546 088	177	3 842 547 061	71	3 842 547 131	139

3 842 547 132	139	3 842 547 895	132	3 842 552 970	59, 61, 131, 133	3 842 998 291	81, 83, 85, 93, 147, 149, 151, 157, 183
3 842 547 133	139	3 842 547 899	61				
3 842 547 134	139	3 842 547 900	133	3 842 552 972	59, 131		
3 842 547 135	141	3 842 547 904	55	3 842 552 973	59, 131	3 842 998 706/AZ	23
3 842 547 136	141	3 842 547 905	125	3 842 552 974	59, 131	3 842 998 707/AZ	23
3 842 547 137	141	3 842 547 906	125	3 842 552 975	59, 131	3 842 998 708/AZ	23
3 842 547 138	141	3 842 547 908	57, 179	3 842 552 984	89, 155	3 842 998 709/AZ	24
3 842 547 139	141	3 842 547 949	231	3 842 552 985	89, 155	3 842 998 710/AZ	24
3 842 547 140	141	3 842 547 950	231	3 842 553 006	127	3 842 998 711/AZ	25
3 842 547 141	141	3 842 547 951	231	3 842 553 023	45	3 842 998 712/AZ	39
3 842 547 142	141	3 842 547 952	231	3 842 553 028	33	3 842 998 713/AZ	39
3 842 547 143	141	3 842 547 953	231	3 842 553 029	181	3 842 998 714/AZ	40
3 842 547 144	141	3 842 547 954	231	3 842 553 030	181	3 842 998 715/AZ	37
3 842 547 145	141	3 842 547 955	231	3 842 553 031	181	3 842 998 716/AZ	37
3 842 547 146	141	3 842 547 956	231	3 842 553 032	181	3 842 998 717/AZ	27
3 842 547 147	141	3 842 547 971	195	3 842 553 033	181	3 842 998 718/AZ	27
3 842 547 148	141	3 842 547 982	265	3 842 553 034	181	3 842 998 719/AZ	28
3 842 547 149	141	3 842 547 990	195	3 842 553 035	181	3 842 998 720/AZ	31
3 842 547 150	141	3 842 548 797	189	3 842 553 036	181	3 842 998 721/AZ	31
3 842 547 151	141	3 842 548 811	187	3 842 553 047	81, 147	3 842 998 742	91, 95
3 842 547 152	141	3 842 549 015	83, 103, 149, 163	3 842 553 048	81, 147	3 842 998 774	105, 165
3 842 547 153	141			3 842 553 049	81, 147	3 842 998 775	105, 165
3 842 547 154	141	3 842 549 016	83, 103, 149, 163	3 842 553 057	81, 147	3 842 998 776	107
3 842 547 155	141			3 842 553 058	81, 147		
3 842 547 156	141	3 842 549 017	103, 163	3 842 553 059	81, 147		
3 842 547 216	19, 20, 21, 23, 24, 25, 27, 28, 31, 37, 39, 40, 177	3 842 549 018	103, 163	3 842 553 070	217		
		3 842 549 365	169, 189	3 842 553 090	235		
		3 842 549 388	265	3 842 553 184	99, 161		
		3 842 549 727	57, 61, 129, 133	3 842 553 445	98, 160		
3 842 547 227	209			3 842 553 447	97, 159		
3 842 547 228	209	3 842 549 730	57, 61, 129, 133	3 842 553 449	97, 159		
3 842 547 380	91			3 842 553 450	97, 159		
3 842 547 381	91	3 842 549 738	264	3 842 553 451	97, 159		
3 842 547 442	111	3 842 549 835	264	3 842 553 452	97, 159		
3 842 547 443	111	3 842 551 074	251	3 842 553 453	97, 159		
3 842 547 444	111	3 842 551 084	251	3 842 553 454	97, 159		
3 842 547 445	115	3 842 551 086	251	3 842 553 457	98, 160		
3 842 547 446	115	3 842 551 090	247	3 842 553 459	97, 159		
3 842 547 447	115	3 842 551 091	247	3 842 553 512	98, 160		
3 842 547 461	119	3 842 551 100	247	3 842 553 518	265		
3 842 547 464	259	3 842 551 104	247	3 842 553 914	149, 183		
3 842 547 516	87	3 842 551 105	247	3 842 553 915	149, 183		
3 842 547 517	87	3 842 551 108	251	3 842 555 820	83, 103, 149, 163		
3 842 547 518	87	3 842 551 110	247				
3 842 547 519	87	3 842 551 111	247	3 842 555 821	83, 103, 149, 163		
3 842 547 520	87	3 842 551 121	247				
3 842 547 521	87	3 842 551 122	255	3 842 555 822	103, 163		
3 842 547 522	147, 183	3 842 551 124	255	3 842 555 823	103, 163		
3 842 547 523	147, 183	3 842 551 125	255	3 842 557 000	61, 133, 179		
3 842 547 524	147	3 842 551 128	255				
3 842 547 525	147	3 842 551 137	255	3 842 557 004	59, 131		
3 842 547 526	147	3 842 551 138	251	3 842 990 350/L	111, 113		
3 842 547 527	147	3 842 551 139	251	3 842 990 351/L	187		
3 842 547 528	153, 183	3 842 551 140	251	3 842 990 517	189		
3 842 547 529	153, 183	3 842 551 141	251	3 842 992 476/...	227		
3 842 547 530	153	3 842 551 545	69, 181	3 842 993 133/L	115		
3 842 547 531	153	3 842 551 546	69, 181	3 842 993 306/L	195, 203		
3 842 547 532	153	3 842 551 547	69, 181	3 842 993 308/L	169		
3 842 547 533	153	3 842 551 548	69, 181	3 842 993 887/L	202		
3 842 547 703	219	3 842 551 549	69, 181	3 842 994 863/L	203		
3 842 547 707	215	3 842 551 550	69, 181	3 842 996 022/L	53		
3 842 547 712	83	3 842 551 551	69, 181	3 842 996 023/L	53		
3 842 547 713	83	3 842 551 552	69, 181	3 842 996 024/L	53		
3 842 547 718	215	3 842 552 821	99, 161	3 842 996 026/L	2, 55		
3 842 547 727	19, 20, 21, 23, 24, 25, 27, 28, 31, 37, 39, 40, 177	3 842 552 900	101	3 842 996 027/L	125		
		3 842 552 927	127, 132, 149	3 842 996 028/L	55		
		3 842 552 940	85, 151, 183	3 842 996 029/L	125		
		3 842 552 941	85, 151, 183	3 842 996 204/...	224		
3 842 547 729	195	3 842 552 942	85, 151	3 842 996 205/...	224		
3 842 547 892	169	3 842 552 948	185	3 842 996 314	127		

## Index

- A**
  - Accumulation roller chain D11 26
  - AL-ST5 adapter 184
  - Aluminum system 48
    - 90° return unit 88
    - AL leg set 65-120 110
    - AL leg set 160-320 114
    - AL leg sets 108
    - Assembly module AL 61
    - Basic unit AL connection drive 82
    - Basic unit AL head drive direct 80
    - Basic unit curve wheel drive AL 90
    - Basic unit with center drive 84
    - Collar screw 64
    - Connection kit active and passive bridge 102
    - Connection kit alpine conveyor 106
    - Connection kit synchronous drive, external motor/internal motor 104
    - Cover profile 62
    - Cross connector AL 54
    - Curves AL 66
    - Curve wheel AL 68
    - Curve wheel drive leg set 113
    - Drive and return unit AL 76
    - Drive kit 92
    - Drive kit curve wheel AL 94
    - Flange nut 63
    - Frequency converter 96
    - Innovative drive concept 78
    - Manual control unit 99
    - Profile connector AL 60
    - Return unit AL/closed head drive AL 86
    - Roller curve horizontal AL 70
    - Section profile AL closed 52
    - Section profile AL open 54
    - Sections AL 50
    - Slide rail 56
    - Sliding curve horizontal AL 72
    - Steel slide rail 58
    - Supporting bracket AL 116
    - Supporting bracket, lateral AL 118
    - Support profile AL 54
    - Switch/potentiometer unit 99
    - T-bolt 63
    - T-nut 64
    - Transmission kit 100
    - Vertical curve AL 74
  - Assembly module
    - AL 61
    - STS 133
- B**
  - Barrier 216
  - Basic unit
    - Center drive 84, 150
    - Connection drive, AL 82
    - Connection drive, STS 148
    - Curve wheel drive AL 90
    - Head drive direct, AL 80
    - Head drive direct, STS 146, 148
- Bending tool for lateral guide 266
- Bridge
  - Active bridge 102, 162
  - Passive bridge 102, 162
- C**
  - Calculation of chain tensile forces 270
  - Chain assembly tool 264
  - Chain length of the components 278
  - Chain resistance to chemicals 296
  - Chains
    - Flocked chain 44
    - Steel-coated chain 42
  - Clamping lever 213
  - Cleanroom classification 292
  - Cleated chain 36
  - Closed head drive
    - AL 86
    - STS 152
  - Collar screw 64
  - Combination matrix 289
  - Components for lateral guides 200
  - Connection kit active and passive bridge 102, 162
  - Connection kit alpine conveyor 106
  - Connection kit synchronous drive, external motor/internal motor 104, 164
  - Conveyor chains
    - Accumulation roller chain D11, Roller cleat chain D11 26
    - Cleated chain 36
    - Flat conveyor chain 18
    - Flocked chain 44
    - Layout instructions for roller cleat chains 34
    - Roller cleat chain D20 30, 32
    - Roller cleat D35 32
    - Static friction chain 22
    - Steel-coated chain 42
    - Universal chain 38
    - Wedge chain 46
  - Conveyor noise level 294
  - Cover profile 62
  - Cross connector
    - AL 54
    - STS 124
  - Cross-diverter 250
  - Curves
    - AL 66
    - STS 134
  - Curve wheel
    - AL 68
    - AL ESD 180
    - STS 136
  - Curve wheel drive leg set 113
  - Curve wheel lateral guide 230
- D**
  - Design of an ESD system 172
  - Diverter 246
  - Drilling jig 265
  - Drive and return unit
    - AL 76
    - ESD 182
    - STS 142
  - Drive concept
    - AL 78
    - STS 144
  - Drive data 279
  - Drive kit 92, 156
  - Drive kit curve wheel AL 94
- E**
  - End piece 224
  - ESD conveyor chain 176
  - ESD motor leg sets 188
  - ESD system
    - AL-ST5 adapter 184
    - Curve wheel AL ESD 180
    - Design of the system 172
    - Drive and return unit ESD 182
    - ESD conveyor chain 176
    - ESD leg set 186
    - ESD motor leg sets 188
    - ESD slide rail 178
    - Lateral guide 174
    - Workpiece pallet 174
- F**
  - Flange nut 63
  - Flat conveyor chain 18
  - Flocked chain 44
  - Frequency converter motec 8400
    - AL 96, 284
    - STS 158, 284
- H**
  - Horizontal roller curve
    - AL 70
    - STS 138
- I**
  - Identification systems ID 15 and ID 200 260
  - Innovative drive concept
    - AL 78
    - STS 144
- J**
  - Junction 254
- L**
  - Lateral guide 174, 198
    - Barrier 216
    - Clamping lever 213
    - Components for lateral guides 200

– Lateral guide holder, fixed	205	– open	54	Switch/potentiometer unit	
– Lateral guide holder, flexible	207	Section profile STS		– STS	161
– Pneumatically adjustable	214	– Clean	126	Symbols	2
– Sectional rails for lateral guides	202	– open	124		
– Universal diverter	218	Sections		► <b>T</b>	
Lateral guide for workpiece pallets	226	– AL	50	T-bolt	63
Lateral guide holder		– STS	122	Technical data	268
– fix	205	Section transfer	244	– Actual chain and slide rail lengths of components	278
– flexible	207	Slide rail		– Calculation of chain tensile forces	270
Leg set		– AL	56	– Chain resistance to chemicals	296
– 65-120 AL	110	– ESD	178	– Cleanroom classification	292
– 160-320 AL	114	– steel	58, 130	– Combination matrix	289
Leg sets		– STS	128	– Conveyor noise level	294
– AL	108	Slide rail assembly tool	264	– Drive data	279
– ESD	186	Slide rail length of the components	278	– Frequency converter	284
– STS	166, 168	Sliding curve horizontal AL	72	– Material use	298
► <b>M</b>		Stainless steel system	120	– Motor connection	283
Manual control unit		– 90° return unit	154	– Motor data	280, 281, 282
– AL	99	– Assembly module STS	133	– Ordering parameters for SEW motors (GM = 2)	286
– STS	161	– Basic unit with center drive	150	T-nut	64
Material number overview	300	– Connection kit active and passive bridge	162	Tools	262
Material use	298	– Connection kit synchronous drive, external motor/internal motor	164	– Bending tool for lateral guide	266
Motor connection	283	– Curves STS	134	– Chain assembly tool	264
Motor data	280, 281, 282	– Curve wheel STS	136	– Drilling jig	265
► <b>O</b>		– Drive and return unit STS	142	– Slide rail assembly tool	264
Ordering parameters for SEW motors (GM = 2)	286	– Drive kit	156	Transmission kit	100
► <b>P</b>		– Frequency converter	158		
Pneumatically adjustable lateral guide	214	– Innovative drive concept	144	► <b>U</b>	
Positioning unit	240	– Manual control unit	161	Universal chain	38
Position sensor accessory	236	– Profile connector STS	132	Universal diverter	218
Profile connector		– Return unit STS/closed head drive STS	152	► <b>V</b>	
– AL	60	– Section Profile STS Clean	126	Vario Flow plus ESD system	170
– Clean section	127, 290, 291	– Section profile STS open	124	VarioFlow workpiece pallet	222
– STS	132	– Sections STS	122	VE 2/VF stop gate	232
► <b>R</b>		– Slide rail	128	Vertical curve	
Return stop WT	234	– Steel slide rail	130	– AL	74
Return unit		– STS basic direct head drive unit	146, 148	– STS	140
– 90°	88, 154	– STS basic unit connection drive	148	► <b>W</b>	
– AL	86	– STS cross connector	124	Wedge chain	46
– STS	152	– STS horizontal roller curve	138	Wedge conveyor	190
Rocker WT system	258	– STS leg sets	166, 168	– Setting up a wedge conveyor	192
Roller cleat chain		– Support profile STS	124	– Wedge conveyor adjustment unit	194
– D11	26	– Switch/potentiometer unit	161	Wedge conveyor adjustment unit	194
– D20	30, 32	– Vertical curve STS	140	Workpiece pallet	174
– Design information	34	Static friction chain	22	Workpiece pallet system	220
Roller cleat D35	32	Steel-coated chain	42	– Cross-diverter	250
► <b>S</b>		Supporting bracket AL	116	– Curve wheel lateral guide	230
Sectional rails for lateral guides	202	Supporting bracket, lateral AL	118	– Diverter	246
Section profile AL		Support profile		– End piece	224
– closed	52	– AL	54	– ID 15 identification system	260
		– STS	124	– Junction	254
		Switch bracket	238	– Lateral guide for workpiece pallets	226

- Positioning unit	240
- Position sensor accessory	236
- Return stop WT	234
- Rocker WT system	258
- Section transfer	244
- Switch bracket	238
- VarioFlow workpiece pallet	222
- VE 2/VF stop gate	232
- WT plate	224
WT plate	224



**По вопросам продаж и поддержки обращайтесь:**

Алматы (7273)495-231	Казань (843)206-01-48	Новокузнецк (3843)20-46-81	Смоленск (4812)29-41-54
Архангельск (8182)63-90-72	Калининград (4012)72-03-81	Новосибирск (383)227-86-73	Сочи (862)225-72-31
Астрахань (8512)99-46-04	Калуга (4842)92-23-67	Омск (3812)21-46-40	Ставрополь (8652)20-65-13
Барнаул (3852)73-04-60	Кемерово (3842)65-04-62	Орел (4862)44-53-42	Сургут (3462)77-98-35
Белгород (4722)40-23-64	Киров (8332)68-02-04	Оренбург (3532)37-68-04	Тверь (4822)63-31-35
Брянск (4832)59-03-52	Краснодар (861)203-40-90	Пенза (8412)22-31-16	Томск (3822)98-41-53
Владивосток (423)249-28-31	Красноярск (391)204-63-61	Пермь (342)205-81-47	Тула (4872)74-02-29
Волгоград (844)278-03-48	Курск (4712)77-13-04	Ростов-на-Дону (863)308-18-15	Тюмень (3452)66-21-18
Вологда (8172)26-41-59	Липецк (4742)52-20-81	Рязань (4912)46-61-64	Ульяновск (8422)24-23-59
Воронеж (473)204-51-73	Магнитогорск (3519)55-03-13	Самара (846)206-03-16	Уфа (347)229-48-12
Екатеринбург (343)384-55-89	Москва (495)268-04-70	Санкт-Петербург (812)309-46-40	Хабаровск (4212)92-98-04
Иваново (4932)77-34-06	Мурманск (8152)59-64-93	Саратов (845)249-38-78	Челябинск (351)202-03-61
Ижевск (3412)26-03-58	Набережные Челны (8552)20-53-41	Севастополь (8692)22-31-93	Череповец (8202)49-02-64
Иркутск (395)279-98-46	Нижний Новгород (831)429-08-12	Симферополь (3652)67-13-56	Ярославль (4852)69-52-93
Россия (495)268-04-70	Киргизия (996)312-96-26-47	Казахстан (7172)727-132	